

# The Geology and Ground-Water Resources of Calcasieu Parish Louisiana

By ALFRED H. HARDER

---

GEOLOGICAL SURVEY WATER-SUPPLY PAPER 1488

*Prepared in cooperation with the Louisiana Department of Public Works and the Louisiana Geological Survey, Department of Conservation*



**UNITED STATES DEPARTMENT OF THE INTERIOR**

**FRED A. SEATON, *Secretary***

**GEOLOGICAL SURVEY**

**Thomas B. Nolan, *Director***

# CONTENTS

---

	Page
Abstract.....	1
Introduction.....	2
Location and general features of the area.....	2
Purpose and scope of the investigation.....	3
Previous investigations.....	4
Acknowledgments.....	4
Well-numbering system.....	5
Landforms and drainage.....	5
Climate.....	6
General geology.....	8
Deposits of Recent age.....	9
Deposits of Pleistocene age.....	9
Deposits of Pliocene age.....	10
Deposits of Miocene age.....	11
Structure.....	11
General hydrology.....	12
Occurrence of ground water.....	12
Hydraulic characteristics.....	13
Pumping tests.....	13
Specific capacity.....	19
Water-level fluctuations.....	20
Recharge and discharge.....	22
Quality of water.....	23
Temperature of ground water.....	24
Rock formations and their water-bearing properties.....	25
Deposits of Recent age.....	26
Deposits of Pleistocene age.....	26
Chicot aquifer.....	26
Shallow sands.....	26
"200-foot" sand.....	27
"500-foot" sand.....	30
"700-foot" sand.....	34
Deposits of Pliocene age.....	37
Evangeline aquifer.....	37
Deposits of Miocene age.....	40
Withdrawals and their effects.....	40
General conditions.....	40
Chicot aquifer.....	43
"200-foot" sand.....	43
Pumpage.....	43
Effects of pumping.....	44
"500-foot" sand.....	44
Pumpage.....	44
Effects of pumping.....	44
"700-foot" sand.....	53
Pumpage.....	53
Effects of pumping.....	53

	Page
Depth of occurrence of fresh ground water.....	56
Salt-water encroachment.....	56
Lateral movement.....	57
Vertical movement.....	58
Movement in vicinity of structures.....	59
Defective wells.....	59
Corrective measures.....	59
Well construction and methods of lift.....	60
Exploratory methods.....	60
Construction.....	60
Methods of lift.....	63
Summary and conclusions.....	63
Description of wells.....	65
References.....	98
Index.....	101

---

## ILLUSTRATIONS

---

[All plates in pocket]

<b>PLATE</b>	1. Map of Calcasieu Parish showing location of water wells.	
	2. Map showing location of water wells in the Lake Charles industrial district.	
	3. Fence diagram of the Chicot aquifer in Calcasieu Parish.	
	4. Generalized cross sections of the Chicot aquifer in Calcasieu Parish.	
	5. Piezometric map of the "500-foot" sand in Calcasieu Parish, September 1955.	
	6. Contours on top of the "200-foot" sand in Calcasieu Parish.	
	7. Map showing top and thickness of the "500-foot" sand in Calcasieu Parish.	
	8. Map showing top of the "700-foot" sand in Calcasieu Parish.	
	9. Map showing the maximum depth of occurrence of fresh ground water in Calcasieu Parish.	
<b>FIGURE</b>	1. Index map of Calcasieu Parish.....	2
	2. Graph showing annual precipitation at Lake Charles, La., for the years 1893-1955.....	7
	3. Graph showing the normal monthly precipitation at Lake Charles, La., for the period 1893-1955.....	8
	4. Idealized section showing water-table and artesian conditions.....	12
	5. Graph of results obtained from a pumping test in well Cu-590 in the Lake Charles industrial district.....	15
	6. Graph showing the theoretical drawdown in infinite aquifers having different coefficients of transmissibility.....	18
	7. Graph showing relation of specific capacity and yield of well Cu-95.....	20
	8. Graph showing water-level fluctuations in well Cu-77 for the period February 10-16, 1955.....	21
	9. Chart for converting parts per million of chloride to grains per gallon of sodium chloride (NaCl).....	24

CONTENTS

	Page
FIGURE 10. Chart showing the temperature of ground water with relation to depth.....	25
11. Cumulative curves showing grain size of materials from the "200-foot" sand.....	28
12. Theoretical distance-drawdown relation in an infinite aquifer having the hydraulic characteristics determined for the "200-foot" sand.....	29
13. Theoretical time-drawdown relation in an infinite aquifer having the hydraulic characteristics determined for the "200-foot" sand.....	30
14. Cumulative curves showing grain size of materials from the "500-foot" sand.....	31
15. Theoretical distance-drawdown relationship in an infinite aquifer having the hydraulic characteristics determined for the "500-foot" sand.....	33
16. Theoretical time-drawdown relation in an infinite aquifer having the hydraulic characteristics determined for the "500-foot" sand.....	33
17. Cumulative curves showing grain size of materials from the "700-foot" sand.....	35
18. Theoretical distance-drawdown relationship in an infinite aquifer having the hydraulic characteristics determined for the "700-foot" sand.....	36
19. Theoretical time-drawdown relationship in an infinite aquifer having the hydraulic characteristics determined for the "700-foot" sand.....	36
20. Graphs showing the chloride content of water from wells Cu-96, Cu-98, Cu-462, and Cu-463.....	38
21. Graph showing the relation between pumpage from the Chicot aquifer and rainfall during the rice-growing season.....	41
22. Hydrographs of wells screened in the "200-foot" sand.....	42
23. Hydrographs of wells screened in the "500-foot" sand outside the industrial district.....	46
24. Hydrograph of well Cu-22 screened in the "500-foot" sand in the industrial district.....	47
25. Graph showing the relation of water levels in a well to pumpage from the "500-foot" sand in the industrial district....	48
26. Graph showing the relation of water levels in a well to pumpage from the "700-foot" sand in the industrial district....	54
27. Hydrographs of wells screened in the "700-foot" sand outside the industrial district.....	55
28. Graph showing the chloride content of water from well Cu-588.....	57
29. Typical irrigation well.....	62

TABLES

	Page
TABLE 1. Stratigraphic column of Calcasieu Parish.....	8
2. Summary of transmissibility, permeability, and storage coefficients as determined by pumping tests.....	16

	Page
TABLE 3. Theoretical drawdown, in feet, in 4 wells pumping 1,500 gpm each for 100 days under assumed conditions-----	19
4. Distance, in feet, between wells listed in table 3-----	19
5. Ground-water pumpage, in gallons per day, in Calcasieu Parish in 1955-----	40
6. Description of wells in Calcasieu Parish, La-----	66
7. Selected chemical analyses of water from wells in Calcasieu Parish-----	82
8. Drillers' logs of representative wells in Calcasieu Parish-----	86
9. List of wells used in fence diagram-----	97

# THE GEOLOGY AND GROUND-WATER RESOURCES OF CALCASIEU PARISH, LOUISIANA

---

By A. H. HARDER

---

## ABSTRACT

Large quantities of fresh ground water are available in Calcasieu Parish. Fresh water is present in sand of Recent, Pleistocene, Pliocene, and Miocene ages, although locally only small supplies for rural or stock use can be obtained from the shallow sand lenses of Recent and Pleistocene ages. The principal fresh-water-bearing sands are the "200-foot," "500-foot," and "700-foot" sands of the Chicot aquifer of Pleistocene age, from which 105 million gallons is pumped daily. A yield of as much as 4,500 gpm (gallons per minute) has been obtained from a single well. The sands are typical of the Chicot aquifer throughout southwestern Louisiana in that generally they grade from fine sand at the top to coarse sand and gravel at the base of the aquifer.

The coefficient of permeability of the principal sands in Calcasieu Parish ranges from 660 to about 2,000 gpd (gallons per day) per square foot and averages 1,200 gpd per square foot. The permeability of the sands generally varies with textural changes.

The maximum depth of occurrence of fresh ground water in Calcasieu Parish ranges from about 700 feet to 2,500 feet below mean sea level; locally, however, where the sands overlie structures associated with oil fields, the maximum depth is less than 300 feet.

Pumping has caused water levels to decline, at varying rates, in all the sands. In the "200-foot" sand they are declining at a rate of about 2 feet per year. In the industrial district of Calcasieu Parish, levels in the "500-foot" sand are declining at a rate of about 5 feet per year, and in the "700-foot" sand at a rate of about 3.5 feet per year. Salt-water contamination is accompanying the water-level decline in the "700-foot" sand in the central part of the parish.

Quality-of-water data indicate that water from wells screened in the Chicot aquifer generally is suitable for some uses without treatment but would require treatment to be satisfactory for other uses. The temperature of the water ranges from 70° to 79°F.

The lenticular sands of Pliocene and Miocene ages have not been used as a source of fresh ground water in Calcasieu Parish; however, north of the Houston River these formations contain fresh water, and the water contained in these formations in other parts of southwestern Louisiana is known to be soft and suitable for most purposes.

## INTRODUCTION

## LOCATION AND GENERAL FEATURES OF THE AREA

Calcasieu Parish is in southwestern Louisiana (fig. 1) and is bordered on the west by the Sabine River and on the north, east, and south by Beauregard, Jefferson Davis, and Cameron Parishes, respectively. It has an area of 1,070 square miles, an extreme east-west length of about 50 miles, and an extreme north-south length of about 30 miles. In this report the Lake Charles industrial district is considered to be the area along the west side of the Calcasieu River between Moss Lake and the city of Lake Charles. In Calcasieu Parish there are 24 producing oil or gas fields and 1 sulfur mine which, with the refineries and chemical plants in the industrial district near Lake Charles, make the parish an important petroleum and chemical center. At DeQuincy, turpentine and other related products are produced. The principal agricultural products in the parish are rice, lumber, and cattle.

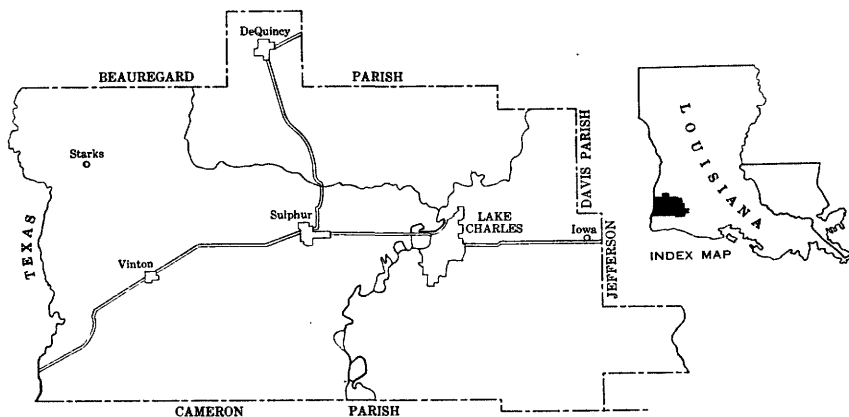

FIGURE 1.—Index map of Calcasieu Parish.

According to the 1950 census the population of the parish was 89,635. The principal city is Lake Charles, a deepwater port on the Calcasieu River. The population of Lake Charles in 1940 was 21,207 and by 1950 had increased 94 percent to 41,272. In addition to the large chemical plants and refineries in the industrial district, there are many small industries across the Calcasieu River in Lake Charles. McNeese State College is in Lake Charles, and the Lake Charles Air Force Base is just outside the city limits.

The city is serviced by the Southern Pacific, the Kansas City Southern, and the Missouri Pacific Railroads; by the Greyhound and Continental Trailways bus lines; and by Trans-Texas Airways and Eastern Air Lines. A deepwater ship channel, first completed



in 1941 and subsequently deepened to 35 feet, connects Lake Charles with the Intracoastal Waterway and the Gulf of Mexico by a route that approximates the natural channel of the Calcasieu River.

#### PURPOSE AND SCOPE OF THE INVESTIGATION

The aquifers underlying Calcasieu Parish provide an important source of water for industrial, municipal, irrigation, and rural use. Water from rivers, lakes, and canals also is used for irrigation and industrial purposes; however, because of the varying temperatures and often poor quality of the surface water, industries and irrigators use large quantities of ground water. In 1955 about 23.7 billion gallons of ground water was pumped by industries, about 9.90 billion gallons for irrigation, about 2.86 billion gallons for municipal supplies, and about 1.46 billion gallons for rural supplies.

It is difficult to determine the dollar value of ground water, because it is used for many different purposes. However, if this source of water, as developed by the industries in Calcasieu Parish, were depleted and had to be replaced by another source at the relatively low industrial rate of 8 cents per thousand gallons, the annual cost of the water used for industrial purposes would be about \$1.9 million.

Because of the expanding industrial and municipal use of ground water and its widespread use for irrigation and rural needs, concern has been expressed about the adequacy of ground-water supplies throughout the parish. Because of the seriousness of salt-water encroachment in the Calcasieu River at Lake Charles (Jones and others, 1956, p. 186), future municipal, agricultural, and industrial developments along the river will be dependent primarily upon wells for an adequate fresh-water supply.

Basic information on ground-water conditions has been collected since 1941. In 1954 a detailed ground-water study of the parish was begun to present the pertinent basic data thus far collected, determine the availability of ground water as indicated by the geologic conditions and the hydrologic properties of the aquifers, determine the occurrence of fresh ground water and its chemical quality, and determine the rates of withdrawals and their effects. This study was made in cooperation with the Louisiana Geological Survey, Department of Conservation, and the Louisiana Department of Public Works. The work was done under the immediate supervision of Rex R. Meyer, district geologist of the Ground Water Branch, United States Geological Survey.

About 670 wells have been inventoried in the parish; records of some of these wells are given in table 6 and their locations are shown on plates 1 and 2. Water-level fluctuations in the principal

aquifers were measured in selected wells to determine changes in storage and effects of pumping. Drillers' logs, electrical logs, and pumping tests were the principal bases for determining the extent of the fresh-water-bearing sands. The ability of the aquifers to store and transmit water was determined by means of pumping tests. Water samples were obtained and analysed to determine the chemical constituents in the water and to outline areas yielding water of high salinity. The amount of water pumped in the area was computed from reports by users, from the rating of individual wells used to irrigate rice, and from estimates of rural use based on population. The maximum depth of occurrence of fresh ground water and the presence of deep aquifers in northern and central Calcasieu Parish were determined chiefly from electrical logs of oil-test wells.

#### PREVIOUS INVESTIGATIONS

Harris and Veatch (1905) were the first to report water levels, chemical analyses, and logs of wells in Calcasieu Parish. Jones (1950) described the occurrence of ground water in the vicinity of Lake Charles. He also named the "200-," "500-," and "700-foot" sands and determined the withdrawals and their effect on water levels. Coefficients of transmissibility and storage and data on the quality of water in the three sands also were presented. Jones, Turcan, and Skitbitske (1954) described the ground-water conditions in Calcasieu Parish in detail in their report on southwestern Louisiana. A more recent paper (Jones and others, 1956) on the same area incorporates the earlier report. Piezometric maps of the principal aquifer in southwestern Louisiana for the period 1952-55 are included in three reports published jointly by the Louisiana Geological Survey and the Louisiana Department of Public Works (Fader, 1954, 1955, and 1957).

#### ACKNOWLEDGMENTS

The author thanks the many people whose excellent cooperation made this report possible. Information on well construction, water consumption, and water quality was made readily available by individual well owners and by the Cit-Con Oil Corp., Cities Services Refining Corp., Columbia-Southern Chemical Corp., Continental Oil Co., Davison Chemical Co., Firestone Tire and Rubber Co., Greater Lake Charles Water Co., Gulf States Utilities Co., Newport Industries, Inc., Olin Mathieson Chemical Corp., and Petroleum Chemicals, Inc. Irrigation well owners and industrial officials were very helpful in making wells available for pumping tests. The Coastal Water Well Corp., Layne Louisiana Co., Stamm-Scheele, Inc., and other water-well contractors provided well-construction data and

drillers' logs. Considerable subsurface information was obtained from electrical logs of oil-test wells made available by Leo W. Hough, State geologist, Louisiana Department of Conservation. Many thanks also are due various State and Federal agencies, the Louisiana Department of Public Works, the Louisiana Department of Highways, the U.S. Corps of Engineers, the U.S. Air Force, and the U.S. Weather Bureau Station at the Lake Charles Air Force Base for pertinent data supplied by them. The Louisiana State Rice Milling Co. and the U.S. Department of Agriculture provided rice-acreage and water-source data.

#### WELL-NUMBERING SYSTEM

All wells inventoried by the U.S. Geological Survey in Calcasieu Parish are designated by the prefix "Cu," a symbol for the parish, followed by a number denoting a specific well in the parish. Where possible, all wells are located to the closest 16th section within the proper township and range. A record of each well is kept on file, and the well's location is plotted on a map. Data on wells pertinent to this report are given in table 6, and the well locations are shown on plates 1 and 2.

#### LANDFORMS AND DRAINAGE

Calcasieu Parish lies in the West Gulf Coastal Plain (Fenneman, 1938, p. 102). It is an area of low relief—the altitude ranges from about 2 feet on the flood plains of the Sabine and Calcasieu Rivers to about 90 feet in the area northwest of DeQuincy. North of the Houston River the land is somewhat hilly, and altitudes range from about 20 to 90 feet, whereas south of the Houston the land is a very flat plain whose altitude ranges from 25 feet near the river to about 2 feet in the coastal marsh. The minimum slope of the coastwise Pleistocene terrace is about 2 feet per mile, whereas the slope of the Recent flood plains generally is less than, and is dependent upon, the gradient of the streams which formed them. Meander scars, representing courses of ancestral streams, and pimple mounds are present on the Pleistocene surface throughout the parish. The pimple mounds are low circular or elliptical hillocks, generally 30 to 50 feet in diameter and about 1 to 5 feet in height (Jones and others, 1956, p. 25). Within the past 10 years farmers have made considerable use of land-leveling machinery to smooth out these irregularities because of their hindrance to irrigation and planting.

The flood plains are usually swampy in comparison to the surrounding uplands; consequently, the plant growth on the flood plains is quite different from that on the better drained Pleistocene surfaces. The flood plains contain such trees as oak, gum, and

magnolia, and a very dense undergrowth, whereas the Pleistocene surface not under cultivation contains grassland and pine trees.

The parish is drained by the Calcasieu and Sabine Rivers and their tributaries. One of the largest tributaries of the Calcasieu River is the Houston River, which, with its tributaries, drains most of the northwestern part of the parish.

#### CLIMATE

The climate of Calcasieu Parish is mild and is typically that of the Gulf Coast States. The average annual temperature for the period 1900-55 was 68°F. The highest temperature recorded during this period was 104°F in August 1951, and the lowest was 12°F in January 1948. The coldest year was 1940, which had an average annual temperature of 65.7°F. The warmest year was 1927, which had an average annual temperature of 71.3°F. The average annual rainfall for the period 1893-1955 was 57.82 inches. The wettest year was 1919, when there was 79.88 inches of rainfall; and the driest year was 1954, when there was 30.08 inches of rainfall. The annual precipitation at Lake Charles for the years 1893-1955 is shown on figure 2. During this period the greatest monthly rainfall was 17.9 inches in June 1947, and the least was 0.05 inch in October 1952. The normal monthly rainfall for the same period is shown on figure 3.

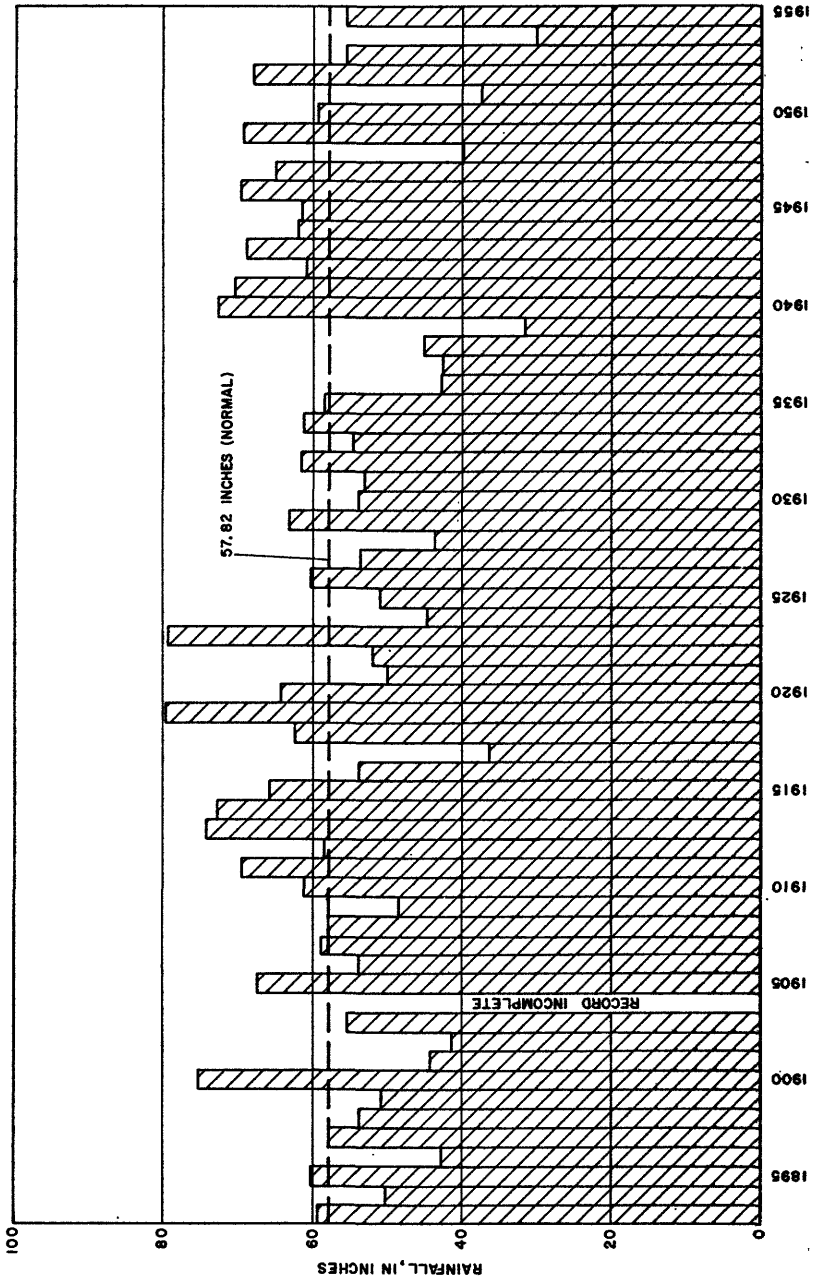

FIGURE 2.—Graph showing annual precipitation at Lake Charles, La., for the years 1898-1956.

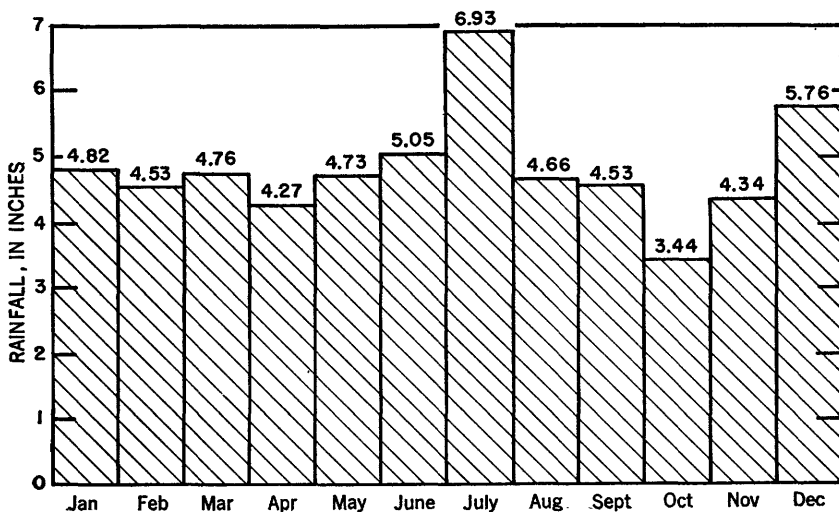

FIGURE 3.—Graph showing the normal monthly precipitation at Lake Charles, La., for the period 1893-1955.

### GENERAL GEOLOGY

Calcasieu Parish lies within the Gulf Coastal Plain province and is immediately underlain by Recent and Pleistocene deposits of Quaternary age. (See table 1.) These deposits occur throughout southern Louisiana and parts of northern Louisiana. In Calcasieu Parish they are underlain by southward-dipping sedimentary rocks of Tertiary age, which crop out in Texas and northern Louisiana.

TABLE 1.—Stratigraphic column of Calcasieu Parish showing sources of fresh ground water

Era	System	Series	Formation	Faunal zone	Aquifer	Water-bearing properties	
Cenozoic	Quaternary	Recent	Alluvium			Yields small supplies for domestic use. Water is generally hard and contains iron.	
		Pleistocene	Prairie formation. Montgomery formation. Bentley formation. Williana formation.		Chicot Shallow. "200-foot" "500-foot" "700-foot"	Large quantities of hard water available. Individual wells yield as much as 4,500 gpm.	
	Tertiary	Pliocene	Foley formation			Evangeline	Yields small to moderate quantities of soft water, reportedly as much as 300 gpm.
		Pliocene(?) and Miocene.	Fleming formation of Fisk (1940).	<i>Rangia johnsoni</i> , <i>Potamides matsoni</i> .			Contains fresh water in northern part of parish.
		Miocene(?)	Catahoula formation.	<i>Discorbis</i> , <i>Heterostegina</i> , <i>Marginalina</i> .			Contains no fresh water.

The outcrop belts of the sedimentary rocks of Quaternary and Tertiary age roughly parallel the gulf coastline from Texas to Florida except in the Mississippi River embayment area.

The surface contacts between the deposits of Recent and Pleistocene ages are not well defined everywhere, but in many places they are marked by a scarp or a slight change in the slope of the land surface and by dissimilar vegetation. However, because of similar lithologic character and lack of distinctive fossils, the deposits in the subsurface usually are extremely difficult to differentiate.

#### DEPOSITS OF RECENT AGE

Deposits of Recent age occur along the southern edge of the parish and in the Sabine and Calcasieu River valleys and some of their tributaries. These deposits were laid down in the Gulf of Mexico and in the valleys of streams. They generally consist of fine sand, silt, clay, and a few thin lenses of coarser sand. The deposits range from narrow belts along small streams to a maximum width of about 5 miles in the Calcasieu River basin.

#### DEPOSITS OF PLEISTOCENE AGE

Deposits of Pleistocene age crop out in almost all parts of Calcasieu Parish. During Pleistocene time, ice covered the northern part of the North American Continent at least four times. As a result of each of these glaciations, sea level was lowered and gulf-coast streams cut valleys while adjusting to new base levels. Melting of the ice resulted in great quantities of sediment being carried by streams southward from the glaciated areas and deposited on the Gulf Coastal Plain. This stream-transported sediment now forms a thick blanket over much of central and southern Louisiana. Fisk (1940, p. 175) identified and named four different depositional terraces (table 1) in north-central Louisiana which he correlated with the fluctuations of sea level during Pleistocene time. Three of these terraces—the Prairie, the Montgomery, and the Bentley—are exposed at the surface in Calcasieu Parish. The youngest terrace, the Prairie, covers most of Calcasieu Parish, extending from the southern edge to the Houston River. It occurs also along the Sabine and Calcasieu River valleys to the northern boundary of the parish. The Montgomery terrace extends northward from the Houston River to a northeast line about 2 miles north of DeQuincy. The Bentley terrace is present in a small area about 2 miles northwest of DeQuincy. During the course of this study, no evidence was found that the subsurface deposits correlate with these terraces.

In a report on the ground-water resources of southwestern Louisiana, Jones (Jones and others, 1954, p. 138) named the system

of aquifers formed by the Pleistocene deposits "the Chicot reservoir." To eliminate confusion with surface-water reservoirs, the name has been modified to "Chicot aquifer." (See table 1.) Generally, the Chicot aquifer consists of thick deposits of gravel, sand, and clay grading from fine material at the top to coarser material at the base. The base of the Chicot aquifer is usually identified as the base of the deepest gravel layer penetrated by wells (Jones and others, 1954, p. 62). In Calcasieu Parish the principal fresh-water-bearing sands are the "200-," "500-," and "700-foot" sands, so named for the depths at which they occur in the Lake Charles industrial district (Jones, 1950). Although these sands are separate hydrologic units in most of Calcasieu Parish, they become one hydrologic unit just outside the northeast boundary of the parish. In Calcasieu Parish the base of the "700-foot" sand is considered to be the base of the Chicot aquifer. This correlation is the same as that determined from previous studies. In the industrial district the base of the Chicot aquifer, or Pleistocene deposits, is 900 feet below mean sea level. This conforms closely to determinations made by Fisk (1944, fig. 70) and Jones and others (1956, pl. 8), who show the contact between the Pleistocene and Tertiary deposits to be about 1,000 feet below sea level in the industrial district.

#### DEPOSITS OF PLIOCENE AGE

Underlying the Chicot aquifer in Calcasieu Parish is the Evangeline aquifer, which consists of a series of fine to medium sand, silt, and clay within the Foley formation of Pliocene age (Jones and others, 1956, p. 51). Typically these sediments are lignitic and are gray and blue to black as contrasted with the rusty-brown and buff sediments of the overlying Pleistocene strata. There are no known diagnostic markers, lithologic or fossiliferous, that enable correlation of the beds with others. According to Jones and others (1954, p. 57), the Foley formation lies near the surface in northern Beauregard, Allen, and Evangeline Parishes, where it is covered by a thin veneer of Pleistocene deposits. From this area the formation dips southward and is present throughout southwestern Louisiana.

The upper part of the Miocene beds immediately underlying the Foley formation is marked by the clam *Rangia (Miorangia) johnsoni*. Fisk (1944, fig. 68) maps the top of the Miocene beds at a depth of about 2,500 feet below mean sea level at Lake Charles. As the base of the deposits of Pleistocene age is about 700 feet below mean sea level (pl. 4), the Pliocene deposits are considered to be about 1,800 feet thick at Lake Charles. The data presented by Jones and others (1956, pl. 8) and Fisk (1944, fig. 68) indicate that the thickness of the Evangeline aquifer generally increases



toward the south in Calcasieu Parish. At DeQuincy in the northern part of the parish, the thickness is about 1,000 feet. Considerable additional data are needed to establish definitely the age and correlation of sedimentary rocks of Pliocene age in Calcasieu Parish.

#### DEPOSITS OF MIOCENE AGE

Underlying the Pliocene deposits are the Fleming formation of Fisk (1940) and the Catahoula formation of Miocene(?) age. The top of the *Rangia johnsoni* faunal zone is used to mark the top of the Miocene rocks by gulf-coast geologists (Fisk, 1944, fig. 68). These formations generally consist of lenticular beds of gray sand, silty clay, and clay that have a total combined thickness of about 7,000 feet at DeQuincy (Fisk). However, because no water wells penetrate these deposits in Calcasieu Parish, formation samples for either lithologic or faunal determinations were not available for study.

#### STRUCTURE

Calcasieu Parish lies near the east-trending axis of the gulf-coast geosyncline, which coincides approximately with the Louisiana coastline. During subsidence of the geosyncline throughout Cenozoic time, thick wedge-shaped deposits of clay, silt, sand, and gravel were laid down. These deposits are thickest (about 30,000 feet) along the axis of the geosyncline.

Regional faulting of sedimentary rocks as young as Pleistocene has occurred in Calcasieu Parish in the vicinity of the Houston River (Jones and others, 1954, p. 100). Local deep-seated faults are commonly found during exploration for oil. Generally these faults have an eastward trend. This faulting may be related to: the Cascadian revolution (a period of considerable widespread crustal disturbance), which began in Miocene time and lasted well into late Pleistocene time; crustal instability related to the subsidence that is occurring south of the Cameron-Calcasieu Parish line and the uplift occurring north of this line (Howe and others, 1935, p. 37); and local penetration of salt plugs into the strata of Pleistocene age (Howe and others, 1935, p. 87).

Structural features such as salt domes show a marked effect on the occurrence of fresh ground water. (See pl. 9.) In Calcasieu Parish there are 24 oil or gas fields, of which 6 are associated with salt domes—the Starks, Edgerly, Sulphur Mines, Iowa, Vinton, and Lockport. Some of these salt plugs have risen to within 1,200 feet of the surface and have resulted in faulting of the overlying and surrounding strata. These faults probably are restricted to the vicinity of the dome. Evidence of possible faulting in the vicinity of the Starks dome is indicated by the occurrence of salt-water-

bearing sand at a depth of less than 300 feet below sea level. (See pl. 9.) The irregularity of deposition during the Pleistocene with regard to thickness and distribution of individual beds makes the delineation of fault zones extremely difficult. Much more information is needed to establish definitely the exact geologic and hydrologic relationship existing between geologic structural features and fresh-water aquifers.

## GENERAL HYDROLOGY

### OCCURRENCE OF GROUND WATER

Ground water may be defined as that part of the subsurface water in the zone of saturation (Meinzer, 1923, p. 38). It is the water that is available to wells or is discharged through springs. The source of essentially all ground water is precipitation in the form of rain or snow; part of this precipitation runs off from the surface of the ground directly into lakes or streams, part is returned to the atmosphere by evapotranspiration, and the remainder percolates down to the water table, replenishing the aquifers. Ground water is discharged from aquifers by means of wells; by movement into overlying or underlying aquifers; by springs; by effluent seepage to streams, canals, and lakes; and by evapotranspiration where the water table is near the land surface.

Ground water occurs under water-table conditions in areas where the water falling on the land surface can percolate downward through pore spaces in the ground to the zone of saturation. The upper surface of this zone of saturation is the water table. (See fig. 4.) Artesian conditions exist where the water-bearing formation

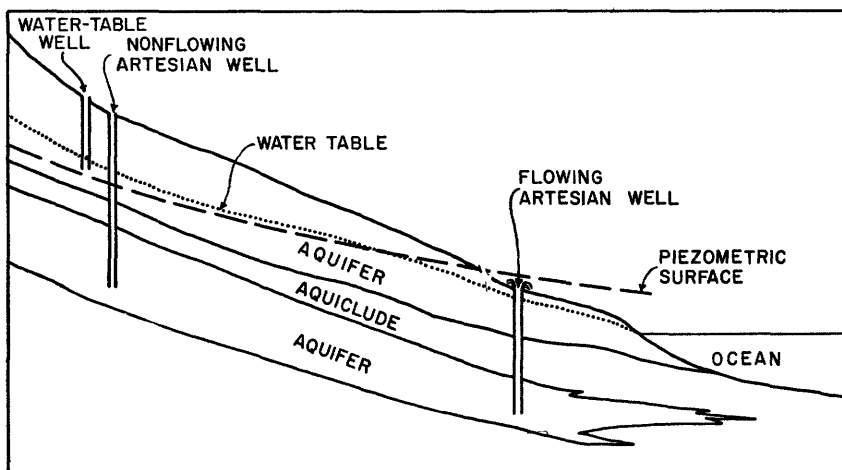

FIGURE 4.—Idealized section showing water-table and artesian conditions.

(aquifer) is overlain by a less permeable formation (aquiclude) and the water in the aquifer is under hydrostatic pressure, rising above the aquifer in wells penetrating it. The piezometric surface is an imaginary surface representing the height, with reference to a common datum such as sea level, to which water will rise in a well tapping an artesian aquifer. Throughout Calcasieu Parish the water in the principal water-bearing sands is under artesian pressure and thus, although not flowing, the wells in these sands are considered to be artesian wells.

#### HYDRAULIC CHARACTERISTICS

The amount of water that a material can hold is a direct function of its porosity. Where the pore spaces are large and interconnected, as they commonly are in sand and gravel, water is transmitted more or less freely, and the material is said to be permeable. Where the pore spaces are small, as in clay, water is transmitted slowly and the clay is said to be semipermeable or impermeable. Alluvial deposits of sand and gravel usually are very permeable and are considered good aquifers. Clay and silt deposits are relatively impermeable and are considered poor aquifers, even though they usually have a higher porosity than sand and gravel. A measure of the ability of a material to transmit water is given by the field coefficient of permeability ( $P_f$ ), which may be defined as the rate of flow of water in gallons per day through a cross-sectional area of 1 square foot under a hydraulic gradient of 100 percent at the prevailing ground-water temperature. The field permeability ( $P_f$ ) multiplied by the thickness of the aquifer ( $m$ ), in feet, is equal to the coefficient of transmissibility ( $T$ ). The coefficient of transmissibility usually is determined in the field by pumping tests and may be defined as the number of gallons of water transmitted in 1 day through a vertical strip of the aquifer 1 foot wide having a height equal to the saturated thickness of the aquifer under a hydraulic gradient of 100 percent at prevailing ground-water temperature. Under certain conditions the coefficient of storage ( $S$ ) may be determined concomitantly with the coefficient of transmissibility. The coefficient of storage of an aquifer represents the volume of water released from storage or taken into storage per unit surface area of the aquifer per unit change in the component of head normal to that surface. These two coefficients are the principal hydraulic characteristics of an aquifer used in computations of ground-water flow.

#### PUMPING TESTS

The data obtained from pumping tests using one or more observation wells are used to calculate transmissibility and storage coefficients. Theis (1935, p. 519-524), utilizing an analogy of the flow of ground

water to the flow of heat by conduction, developed the nonequilibrium formula for computing the coefficients of storage and transmissibility. The formula is—

$$s = \frac{114.6Q}{T} \int_{\frac{1.87r^2S}{Ti}}^{\infty} \frac{e^{-u}}{u} du \quad (1)$$

where—

$s$  is drawdown, in feet, at observation well

$Q$  is discharge, in gallons per minute

$T$  is coefficient of transmissibility, in gallons per day per foot

$r$  is distance, in feet, from observation well to pumped well

$S$  is coefficient of storage

$t$  is time, in days, since pumping started.

The Theis nonequilibrium formula assumes that the aquifer is of infinite areal extent and uniform thickness and is homogeneous and isotropic (conducts water with equal facility in all directions), that the coefficients of transmissibility and storage in the aquifer remain constant at all times and places, that the pumped well is of infinitesimal diameter and completely penetrates the aquifer, and that water is released from storage instantaneously with a decline in artesian head. From the formula, it is apparent that the rate of drawdown in an observation well is directly proportional to the discharge rate of the pumping well. Therefore, for any value of transmissibility and storage at any time and distance, an increase or decrease in the discharge rate will cause a proportionate increase or decrease in the theoretical drawdown; for example, doubling the discharge rate will double the theoretical drawdown.

During this study, pumping tests were made in the winter when pumping for irrigation was negligible and industrial requirements were at a minimum, and a maximum number of observation wells could be used without adversely affecting normal operations. However, despite determined efforts of well owners to regulate pumping, it was not possible to make long-period pumping tests because of varying discharge rates caused by the breakdown of equipment and fluctuations in normal line pressure. During the tests, discharge measurements were made by means of water meters, orifices, Cox flowmeters, and the trajectory method. Depth-to-water measurements in wells were made by using electric tapes, steel tapes, and water-stage recorders readable to the nearest hundredth of a foot. For a period before each test, water levels were measured to determine the water-level trend, for use in adjusting the water-level drawdown or recovery data obtained during the test.

The coefficients of transmissibility and storage were determined as follows (Wenzel, 1942, p. 87): The adjusted drawdown or recovery

values were plotted against time on logarithmic paper and the resulting curve was matched, by superposition, with a type curve derived from the Theis nonequilibrium formula. After matching with the type curve, values of  $W(u)$ ,  $u$ , drawdown ( $s$ ), and time ( $t$ ) were obtained for substitution in the formula. To facilitate computations, these values were determined by selecting a match point on the observed data graph where  $W(u)$  and  $u$  are equal to 1. A typical plot of observed data and its relation to the type curve is shown in figure 5.

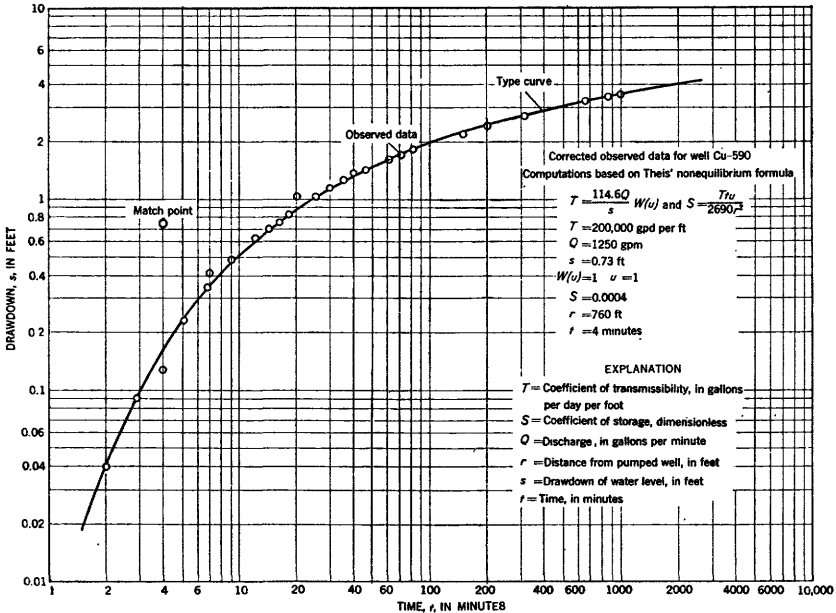

FIGURE 5.—Graph of results obtained from a pumping test in well Cu-590 in the Lake Charles industrial district.

The Theis formula, as modified by Ferris (1948) and by others, can be used to determine the presence of hydrologic boundaries. However, owing to test-time limitations no effects of hydrologic boundaries, either recharge or barrier, were shown by the drawdown and recovery curves. Future pumping tests made over a longer period of time may indicate the presence of boundaries and supplement the available geologic and hydrologic information.

The calculated storage coefficients indicate that water in the "200-," "500-," and "700-foot" sands is under artesian conditions. The values of transmissibility, permeability, and storage calculated from data obtained during pumping tests, length and type of tests, wells used, owners, aquifers tested, and sand thicknesses are listed in table 2. As the coefficient of transmissibility is a function of the

TABLE 2.—Summary of transmissibility, permeability, and storage coefficients as determined by pumping tests

Well	Owner	Sand thickness (feet)	Coefficient of transmissibility (gpd per ft)	Field coefficient of permeability (gpd per sq ft)	Coefficient of storage	Duration of test (minutes)	Date	Method
"200-foot" sand								
Cu- 88 1.....	Continental Oil Co.....	123	120,000	950	-----	379	10-14-43	Recovery.
90 1.....	do.....	116	75,000	660	-----	233	10-11-43	Do.
497.....	F. Helms.....	175	270,000	1,520	0.00082	260	2- 3-55	Drawdown interference.
497.....	do.....	175	270,000	1,520	.00082	260	2- 3-55	Recovery interference.
653.....	G. Nately.....	175	260,000	1,500	.00091	250	2- 3-55	Do.
653.....	do.....	175	260,000	1,500	.00091	250	2- 3-55	Drawdown interference.
"500-foot" sand								
Cu- 33 1.....	Greater Lake Charles Water Co.....	125	140,000	1,080	0.00060	1,463	2-10-44	Recovery.
76.....	Firestone Tire & Rubber Co.....	170	180,000	1,060	.00031	1,350	10-11-54	Drawdown interference.
76.....	do.....	170	180,000	1,090	.00057	1,300	10-11-54	Recovery interference.
95.....	Cities Service Ref. Corp.....	160	200,000	1,160	.00051	1,160	10-11-54	Drawdown interference.
95.....	do.....	160	200,000	1,240	.00064	820	10-11-54	Recovery interference.
97.....	Petroleum Chemicals, Inc.....	165	180,000	1,090	.00037	1,390	10-11-54	Drawdown interference.
97.....	do.....	165	200,000	1,180	.00043	1,320	10-11-54	Recovery interference.
263.....	M. Drost.....	140	150,000	1,070	.00059	300	11-10-54	Do.
263.....	do.....	140	140,000	960	.00060	300	11-10-54	Drawdown interference.
445.....	Cities Service Ref. Corp.....	153	210,000	1,370	.00025	250	10-11-54	Recovery interference.
469.....	Olin Mathieson Corp.....	135	160,000	1,150	.00065	430	3- 7-55	Drawdown interference.
469.....	do.....	135	160,000	1,190	.00068	410	3- 7-55	Recovery interference.
585.....	Jefferson Lake Sulphur Co.....	230	280,000	1,220	.0011	580	7-14-54	Do.
585.....	do.....	230	280,000	1,220	.0011	680	7-14-54	Drawdown interference.
590.....	Cities Service Ref. Corp.....	160	180,000	1,160	.00033	1,360	10-11-54	Do.
590.....	do.....	160	200,000	1,220	.00049	1,000	10-11-54	Recovery interference.
624.....	Davidson Chemical Co.....	140	130,000	960	.00045	380	11- 9-54	Do.
624.....	do.....	140	130,000	930	.00041	350	11- 9-54	Drawdown interference.
Cu- 59 1.....	R. Stine.....	210	220,000	1,020	.00062	170	12-13-54	Do.
Be-369 1.....	S. Caldwell.....	290	560,000	1,950	.00011	300	12-15-54	Recovery interference.

"700-foot" sand

CU- 31	Greater Lake Charles Water Co.	140	180,000	1,180	0.00025	1,316	2-7-44	Recovery.
36	do.	140	180,000	1,260	0.00025	1,260	2-7-44	Recovery interference.
36	do.	140	180,000	1,220	0.00025	1,290	2-9-44	Drawdown interference.
37	do.	140	180,000	1,250	.00023	1,260	2-9-44	Recovery interference.
38	do.	140	180,000	1,070	.0017	1,290	2-9-44	Drawdown interference.
446	Cities Service Ref. Corp.	140	180,000	1,360	.00061	1,405	10-1-54	Recovery interference.

1 Pumped well. \* Well in Cameron Parish. † Well in Beauregard Parish.

aquifer's permeability and thickness, a thickening or thinning of the aquifer will, if the permeability is constant throughout the aquifer, produce a corresponding change in value of the coefficient of transmissibility. The effect on drawdowns caused by changes in the coefficient of transmissibility is shown on figure 6. Graphs

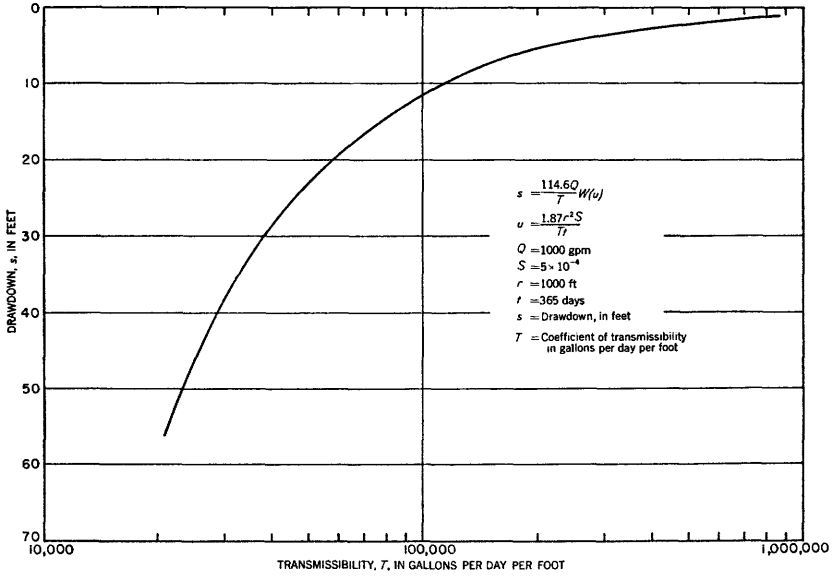

FIGURE 6.—Graph showing the theoretical drawdown in infinite aquifers having different coefficients of transmissibility.

showing the theoretical effects of pumping from aquifers having transmissibility and storage coefficients determined for each principal sand are included in the section “Rock formations and their water-bearing properties.”

The effect on water levels of pumping in a well field also can be predetermined using the coefficients of transmissibility and storage. For example, in table 3 the drawdown of water levels are tabulated for a field consisting of four wells, 8 inches in diameter, tapping an ideal aquifer. These computations are based on the following assumptions: The distance between the wells is as shown in table 4; all wells started pumping simultaneously at a rate of 1,500 gpm each for 100 days; the coefficients of transmissibility and storage are 200,000 gpd per foot and 0.0005, respectively; and the wells have an efficiency of 100 percent.

A well assumed to be 100 percent efficient is a discharging well in which the water level is at the same level as that immediately outside the well—that is, a well in which there are no well-entrance losses. Because of construction factors, such as incomplete well



TABLE 3.—*Theoretical drawdown, in feet, in 4 wells pumping 1,500 gpm each for 100 days under assumed conditions*

Well	1	2	3	4
1.....	19.0	11.4	9.6	9.1
2.....	11.4	19.0	10.0	9.1
3.....	9.6	10.0	19.0	9.8
4.....	9.1	9.1	9.8	19.0
Total drawdown.....	49.1	49.5	48.4	47.0

TABLE 4.—*Distance, in feet, between wells listed in table 3*

Well	1	2	3	4
1.....	0	100	300	400
2.....	100	0	240	410
3.....	300	240	0	280
4.....	400	410	280	0

development and improper selection of screen apertures, the measured drawdown in a pumped well is usually greater than the theoretical drawdown.

#### SPECIFIC CAPACITY

The specific capacity of a well is defined as the yield per unit of drawdown of water level in the well for a given time. It is commonly expressed in terms of gallons per minute per foot of drawdown (gpm per foot). The specific capacity of a well is dependent primarily on the well's effective diameter, the degree of development or efficiency of the well, and the transmissibility of the formation.

Specific-capacity data may be used to:

1. Compare the capabilities of different aquifers to yield water to wells. Wells screened in the Chicot aquifer have average reported and measured specific capacities of 24 to 40 gpm per foot, whereas wells screened in the Evangeline aquifer have specific capacities ranging from 2 to 20 gpm per foot (Jones and others, 1954, p. 132). This difference indicates the greater ability of the Chicot aquifer to yield water to wells.

2. Measure the well efficiency or determine the adequacy of well development. Specific capacities determined during the course of development of a new well will increase to an optimum value, depending on the hydraulic characteristics of the aquifer and on the construction of the well. On the basis of the average coefficients of transmissibility and storage determined for the "500-foot" sand in the industrial district, a 12-inch well, 100 percent efficient, has a theoretical specific capacity of 80 gpm per foot at the end of 1 day of continuous pumping. The observed specific capacities of "500-

foot" wells generally are about 40 gpm per foot. Theoretically, therefore, the wells have an average efficiency of about 50 percent.

3. Determine optimum pumping rates. Figure 7 is a plot of specific capacity and discharge for well Cu-95, an industrial well in Calcasieu Parish. It shows that as the pumping rate increases above 600 gpm the specific capacity decreases. The decrease, probably the result of a change from laminar to turbulent flow in the vicinity of

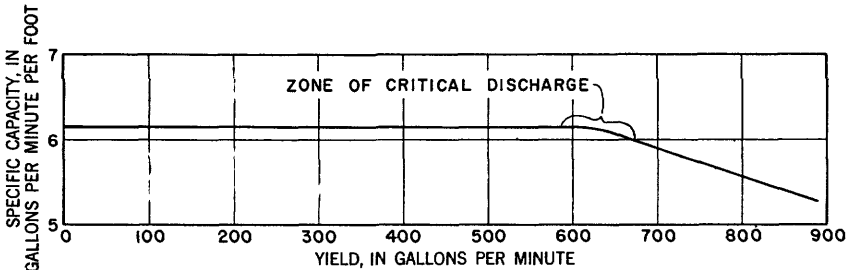

FIGURE 7.—Graph showing relation of specific capacity and yield of well Cu-95.

the well screen, indicates the critical discharge or optimum pumping rate for well Cu-95 to be about 600 gpm.

4. Indicate whether the decline in yield of a well is caused by well or pump failure. If the yield of a well declines but the specific capacity remains unchanged, the decline in yield is the result of declining areal water levels or faulty pumping equipment, whereas, if a decline in yield is accompanied by a decrease in specific capacity, the efficiency of the well has declined and the need for redevelopment is indicated. For example, in 1942 the specific capacity of well Cu-95 was 32 at a yield of 1,500 gpm, and in 1956 the specific capacity was about 6 at an optimum yield of 600 gpm. (See fig. 7.)

#### WATER-LEVEL FLUCTUATIONS

Water levels in wells penetrating an artesian aquifer fluctuate continuously, owing to pumping and to natural causes such as barometric and tidal changes, and natural discharge. Changes in barometric pressure are usually reflected as diurnal and longer term changes of water levels in wells. Changes in tide level often produce subdued changes of water level in wells adjacent to tidal waters. An increase in barometric pressure produces a decline of the water level in an artesian well, by forcing water out of the well into the aquifer. Conversely, a rise in tide level produces a rise in water levels in artesian wells because of the increased load and consequent compression of the aquifer. Another loading effect that may cause water levels to fluctuate in wells is the weight of trains

that pass nearby. Water-level fluctuations and the effects of a passing train are shown on the hydrograph for well Cu-77 (fig. 8). The small jogs, or vertical lines, are caused by rapid compression of the aquifer when the trains are passing the well. The larger decline and subsequent recovery of water levels shown on figure 8 were caused when nearby wells were turned on and off.

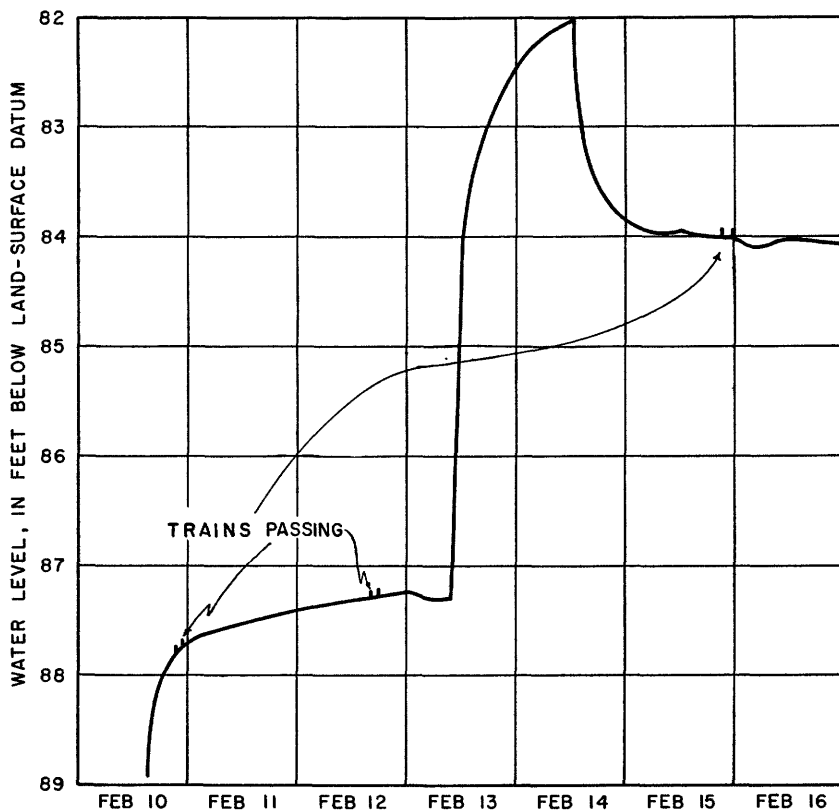

FIGURE 8.—Graph showing water-level fluctuations in well Cu-77 for the period February 10-16, 1955.

Although shallow water-table wells are directly and rapidly affected by changes in the amount of rainfall, there have been no observed water-level changes in wells in the "200-," "500-," and "700-foot" sands in Calcasieu Parish due to normal variations in precipitation. However, changes in temperature and rainfall affect the quantities of water used; this indirectly affects the water levels. Water levels in wells are lowest during the summer when water use is highest. The period of low levels may or may not coincide with a period of low rainfall.

## RECHARGE AND DISCHARGE

Recharge to water-bearing sands in Calcasieu Parish is from precipitation and by movement of ground water into the parish from surrounding areas.

Recharge to the shallow sands of Recent age is by the movement of water from the land surface downward to the water table. Water levels in wells penetrating these deposits usually rise soon after a rain, especially when the soil is not dry enough to absorb all the water before it reaches the water table. Water levels in some water-table wells adjacent to streams rise and fall with stream levels, indicating that the stream serves both as a source of recharge and a means of discharge.

Recharge to the Chicot aquifer occurs principally in the outcrop areas in Beauregard, Allen, Rapides, and Evangeline Parishes. A part of the rainfall in these areas enters the aquifer and moves laterally to points of discharge. In general, the amount of water received is greater than the amount that can be transmitted down-dip, and consequently the excess water is rejected in the recharge area. Many of the streams there, such as the Calcasieu River and some of its tributaries, are hydrologically connected to the aquifer and may serve as a source of recharge or an area of discharge.

The permeability of the clays within and above the Chicot aquifer has not been accurately determined. Locally, however, substantial amounts of recharge to the "500-foot" sand may occur by downward movement of water from the "200-foot" sand, or by upward movement from the "700-foot" sand, through clays in areas where the piezometric surface in the "500-foot" is lower than that in the "200-" and "700-foot" sands. A quantitative estimate of recharge from these sources is given elsewhere in the report under "Vertical movement" in the section "Depth of occurrence of fresh ground water."

Discharge from the Chicot aquifer occurs by natural means and by pumping from wells. In the recharge area of the aquifer, the rejected recharge is discharged naturally into streams; and where the water level is near the land surface, large quantities of water are discharged by evapotranspiration. Prior to the start of intensive pumping of wells in Calcasieu Parish, discharge also occurred down-dip by vertical leakage of water through the confining beds into other aquifers, into streams, and into the Gulf of Mexico.

Recharge to the Evangeline aquifer occurs in its outcrop area where rain falls on the exposed surface. The water then moves down-dip in the aquifer to points of discharge. Discharge from this aquifer in Calcasieu Parish is principally by upward movement through overlying beds into the Chicot aquifer. The amount

of water moving from the Evangeline aquifer into the Chicot aquifer is not now known, but it depends on the thickness and permeability of the intervening beds and the head differential between the aquifers.

#### QUALITY OF WATER

The mineral matter in fresh ground water is derived from the soil and rocks through which the water passes. All minerals are soluble in water to some extent; common salt is readily soluble, whereas quartz is considerably less soluble. Limestone is soluble in water containing carbon dioxide. Because fresh ground water moves very slowly through some rocks, there is adequate time for solution to take place and the water to become mineralized. If a velocity of 0.5 foot per day is assumed, water entering the aquifer in southern Beauregard Parish and removed from the ground in central Calcasieu Parish, a distance of 24 miles, would have nearly 700 years in which to assimilate rock materials. Generally, water-bearing sands containing large quantities of calcium, magnesium, iron, and aluminum minerals yield hard water, and aquifers composed of pure quartz sand will yield soft water. Some hard waters may become softened by passing through sediments containing natural zeolites, which exchange adsorbed sodium for the calcium and magnesium in the water.

Water samples from selected wells throughout the parish were collected and analyzed. The results of analyses made available by companies in the industrial district are included in table 7 in addition to the results of analyses made in the Quality of Water laboratory, Austin, Tex., of the U.S. Geological Survey and field determinations of chloride.

The concentrations of certain dissolved constituents in drinking water (U.S. Public Health Service, 1946, p. 371-384), which preferably should not be exceeded in potable water used on interstate carriers, are shown below:

<i>Constituent</i>	<i>Concentration (ppm)</i>
Iron and manganese (Fe and Mn) -----	0.3
Magnesium (Mg) -----	125
Sulfate (SO <sub>4</sub> ) -----	250
Chloride (Cl) -----	250
Dissolved solids -----	500

A concentration of dissolved solids of 1,000 ppm is permissible if water of better quality is not available. The concentration of fluoride must not exceed 1.5 ppm.

The National Research Council (Maxcy, 1950) in relating nitrate concentrations to the occurrence of methemoglobinemia (blue baby disease) recommends an upper limit of 44 ppm of nitrate as NO<sub>3</sub> in water used for infant feeding.

Because the amount of salt in irrigation waters in southwestern Louisiana is often expressed as grains per gallon, figure 9 was prepared so that the concentration of chloride in parts per million can be converted approximately to grains per gallon of sodium

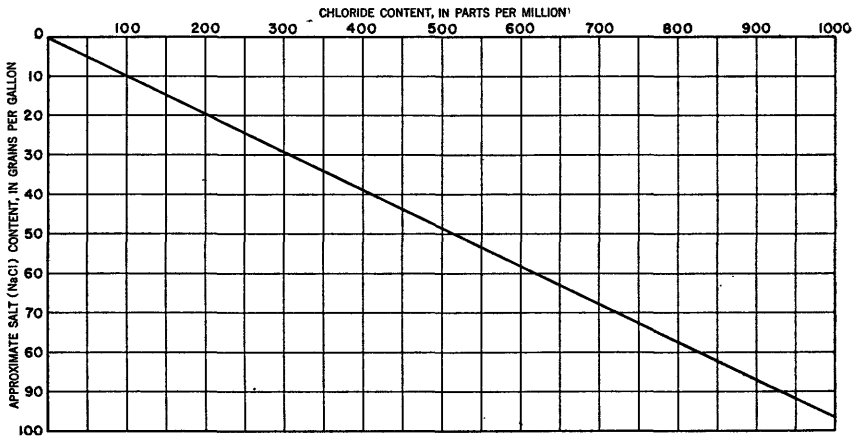

FIGURE 9.—Chart for converting parts per million of chloride to grains per gallon of sodium chloride (NaCl).

chloride. This conversion graph is based on the assumption that all the chloride present in the water is the result of the solution of sodium chloride.

**TEMPERATURE OF GROUND WATER**

The temperature of ground water is often of great importance to industries contemplating use of the water. Ground water usually has a more uniform temperature than surface water; consequently, it is more desirable for certain industrial uses. The temperature of water from the 3 principal aquifers in Calcasieu Parish ranges from 70° to 79°F. Temperatures of water pumped from wells in the “200-,” “500-,” and “700-foot” sands are shown in figure 10. The variations of temperature in wells of the same depth may be due to friction in the pump and casing, method of measurement, entrance of water at different levels in different wells penetrating the same sand, or slight local variations in temperature at the same depth at different places in a given aquifer. A line drawn through the greatest concentration of points indicates that there is a 1°F rise in temperature for about each 70-foot increase in depth. This thermal gradient is in general agreement with that determined in other sections of Louisiana (Meyer and Turcan, 1955, p. 72).

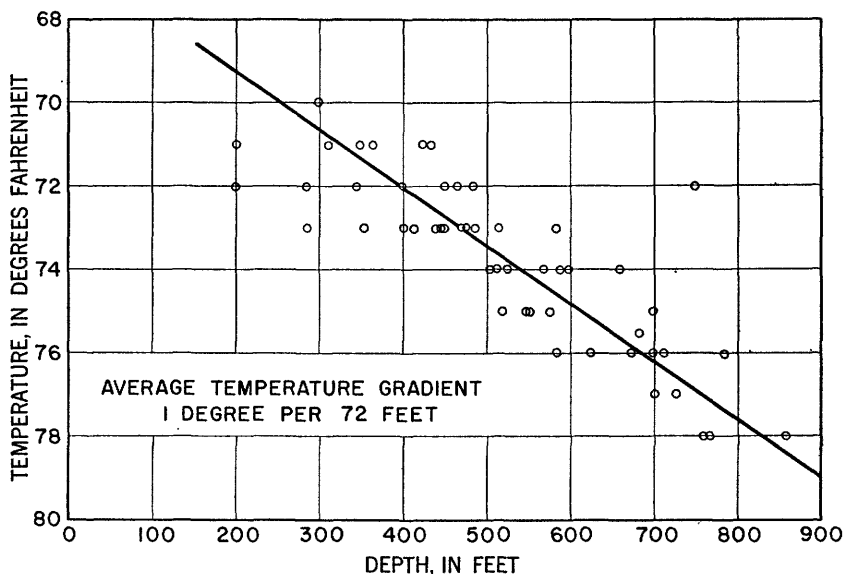

FIGURE 10.—Chart showing the temperature of ground water with relation to depth.

### ROCK FORMATIONS AND THEIR WATER-BEARING PROPERTIES

Ground water occurs in deposits of Recent, Pleistocene, Pliocene, and possible Miocene age in Calcasieu Parish. These deposits, consisting of unconsolidated gravel, sand, silt, and clay, contain fresh water to maximum depths ranging from about 250 feet to about 2,500 feet.

The deposits of Recent age are of small areal extent and supply only small quantities of water to wells. The deposits of Pleistocene age contain thick, extensive water-bearing beds that supply practically all the ground water used in Calcasieu Parish. In the northern part of the parish, deposits of Pleistocene age contain fresh water throughout their entire thickness, whereas in the southern part salt water is present in the lower part of the deposits. Data from electrical logs of oil-test wells indicate that the deposits of Pliocene age contain fresh water only in the extreme northern part of Calcasieu Parish. At present there are no known fresh-water wells screened in these deposits in Calcasieu Parish; however, because of the lack of necessary data it is difficult to correlate exactly the various formations in the vicinity of DeQuincy with known aquifers to the south, and it is possible that the sands below a depth of 500 feet (at DeQuincy) are of Pliocene age. Deposits of this age supply moderate quantities of water in Beauregard, Allen, and Evangeline Parishes.

### DEPOSITS OF RECENT AGE

Shallow wells in deposits of Recent age supply small quantities of water in Calcasieu Parish. These wells are generally less than 50 feet in depth and yield an average of only 2 to 3 gpm. The sands in which the wells are bored or dug range from 1 to 10 feet in thickness and are local in extent. The exact thickness and areal extent of the sand phase of the Recent deposits has not been determined; consequently, it is difficult to estimate the hydrologic characteristics and potential yields of these deposits. The water is moderately hard and in some places is contaminated, as indicated by a chloride content as high as 1,300 ppm.

### DEPOSITS OF PLEISTOCENE AGE

Locally in Calcasieu Parish there are shallow beds of Pleistocene age in the Chicot aquifer which provide small quantities of water for domestic and stock uses. However, the principal water-bearing sands in the Chicot aquifer in Calcasieu Parish are the "200-foot," the "500-foot," and the "700-foot" sands. (See pls. 3 and 4.) The "200-foot" sand supplies water to irrigation and public-supply wells in the eastern part of the parish and to several industrial wells in the central part of the parish. It is also the primary source for domestic wells. The "500-foot" sand is the most heavily developed aquifer in the parish and is the principal source of ground water for industrial needs and irrigation. The "700-foot" sand supplies water to the cities of Lake Charles and DeQuincy, to a few nearby industries, and to irrigators in the south-central part of the parish.

### CHICOT AQUIFER

#### SHALLOW SANDS

A few wells in the southern and central areas of the parish reportedly yield water from a bed of oyster shells and associated beds of silty sand, which occur locally at depths of about 100 feet. These beds usually yield small quantities (less than 100 gpm) of hard water for rural supplies. Locally shallow sand lenses, penetrated by bored, dug, or drilled wells, supply small quantities of ground water for domestic and stock uses throughout the parish. Two wells at the Lake Charles Air Force Base are used for watering animals and have yields of 50 gpm. The amount of water withdrawn from these deposits is probably less than a quarter of a million gallons per day and is not considered in the section on "Withdrawals and their effects."

Locally, water from shallow wells adjacent to streams containing salt water may become contaminated when the stream levels are higher than the ground-water levels. It has been reported that



some shallow wells in the vicinity of the Houston River yielded water of high chloride content. However, there is no apparent contamination of the underlying sands from this source, as indicated by the chemical analyses of water from the "200-foot" sand in this vicinity (table 7).

**"200-FOOT" SAND**

*Distribution and thickness.*—The "200-foot" sand, as shown by the fence diagram (pl. 3) and cross sections *A-A'* and *B-B'* (pl. 4), extends under the entire parish but is irregular in thickness and depth. In general, the sand is thickest in the southeastern part of the parish. For example, the log of well 26 (pl. 3) shows the sand to be 200 feet thick, and that its top is at a depth of 180 feet. At the eastern edge of the parish the sand is 190 feet thick and occurs at a depth of 85 feet. (See well 8, pl. 3; well 20, pl. 4.) In the industrial district, well Cu-92 (well 16, pl. 4) shows the sand to be 70 feet thick and to occur at a depth of 165 feet. At the western edge of the parish the sand is 20 feet thick in well 12 (pl. 4) and is at a depth of 175 feet. Although not shown on plates 3 and 4, the "200-foot" sand in the southwestern part of Calcasieu Parish splits into two, three, or more separate sands. The general dip of the top of the "200-foot" sand is southward at a rate of 4 to 10 feet per mile; however, rapid changes in thickness may locally cause the dip to vary considerably, as in the southwestern part of the parish where it increases to 50 feet per mile. (See pl. 6.) The outcrop and recharge area of the "200-foot" sand is in northern Calcasieu and southern Beauregard Parishes, where in many places it is covered by a clay layer up to 75 feet thick. Where the clay layer is very thick, probably little recharge occurs; however, where it is quite thin or nonexistent, large amounts of water can move down into the sand. It is probable that permeable deposits, contained in the old stream valley now occupied by the upper reaches of the West Fork of the Calcasieu River, locally penetrate through the clay layer and provide a means of recharge to the "200-foot" sand when ground-water levels are below stream levels.

Generally, the "200-foot" sand grades from fine to medium sand at the top to a coarse sand or gravel at the base. In some places, as at Sulphur, the finer materials predominate; in the vicinity of Holmwood, however, there is a complete sequence from fine to coarse sand. The results of mechanical analyses of formation samples from well Cu-560, in the industrial district, are presented in figure 11. The sand grains making up the formation are dominantly subangular quartz grains slightly iron stained, with a small percentage of dark minerals. Where present, the gravel is made up of chert pebbles.

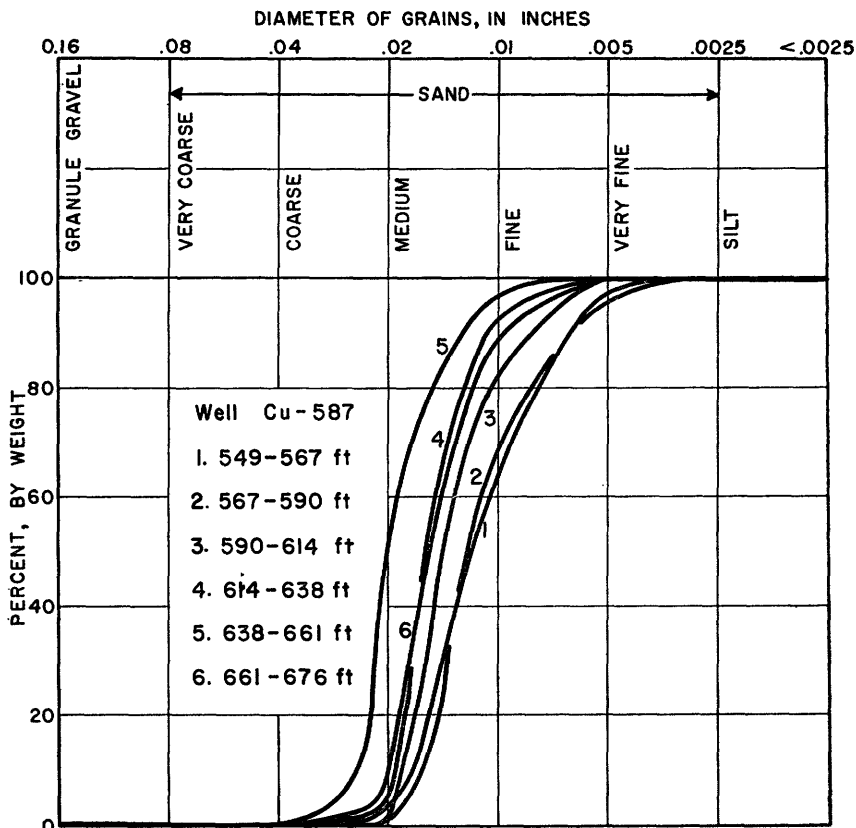

FIGURE 11.—Cumulative curves showing grain size of materials from the "200-foot" sand.

*Hydrology.*—The "200-foot" sand is used mainly to supply water for domestic and irrigation purposes. In the western part of Calcasieu Parish where the aquifer is thin, it provides water only for domestic use; in the central part it provides water for industrial use. In the eastern part of the parish, it is the principal source of water for irrigation and public supply.

Within the industrial district there are two large-capacity wells in the "200-foot" sand. One well had a reported specific capacity of 50 gpm per foot of drawdown at a yield of 2,000 gpm when installed in 1940. In the eastern part of the parish, where the "200-foot" sand supplies most of the water used for irrigation, yields of 10 wells listed in table 7 range from 1,800 gpm to 4,500 gpm and average 2,800 gpm. The results of a pumping test using wells Cu-90 and Cu-88 (at Westlake) indicate an average permeability of 800 gpd per square foot for the "200-foot" sand in the industrial district (table 2). The average coefficients of transmissibility ( $T$ ) and storage ( $S$ ) determined from a test using wells Cu-497 and Cu-633 in the vicinity of Holmwood are 260,000 gpd per foot and

0.00086, respectively. The average permeability of the "200-foot" sand in this area is 1,500 gpd per square foot. The variation in permeability in the "200-foot" sand is typical of the Chicot aquifer throughout southwestern Louisiana and is usually due to texture changes. At Holmwood, where the texture of the aquifer grades from fine to coarse sand, the permeability is about 60 percent greater than at Westlake, where the aquifer is composed primarily of finer materials.

The curves in figures 12 and 13 were computed by using the above-mentioned average coefficients of transmissibility and storage determined for the "200-foot" sand in the Holmwood area. These curves do not take into consideration hydrologic boundaries and changes in the character of the aquifer that might exist. The distance-drawdown curve in figure 12 shows that a well pumping 1,500 gpm for 100 days would cause a theoretical drawdown of about 6.0 feet at a distance of 1,000 feet. The time-drawdown curve (fig. 13) shows that a well pumping 1,500 gpm for 1,000 days would cause a drawdown of 7.5 feet at a distance of 1,000 feet.

*Quality of water.*—Chemical analyses of water from the "200-foot" sand are given in table 7. The water generally is of the sodium bicarbonate type, but it contains sufficient calcium and magnesium as to make it moderately hard to hard. Generally the iron content is less than 1 ppm; however, locally it may be as high as 8.5 ppm, as shown by the analysis for well Cu-347. The temperature of the

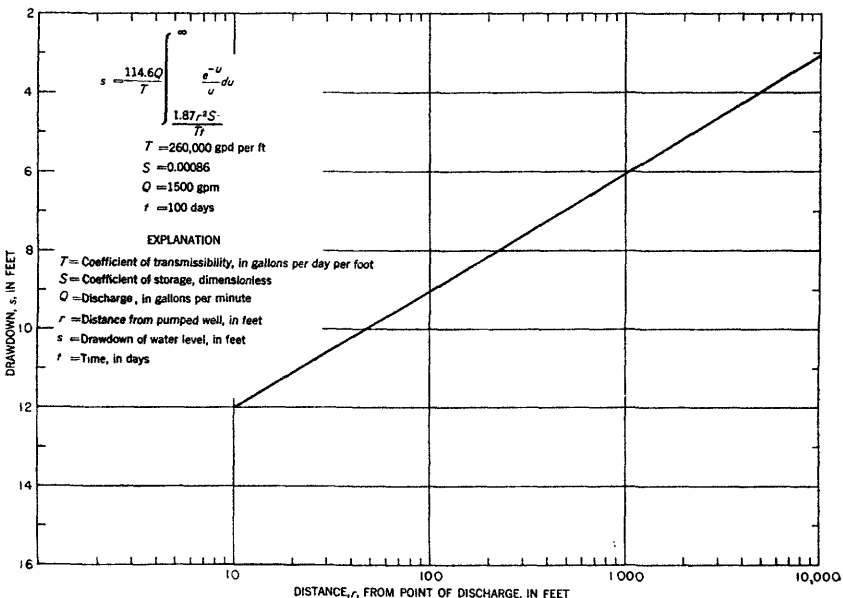

FIGURE 12.—Theoretical distance-drawdown relationship in an infinite aquifer having the hydraulic characteristics determined for the "200-foot" sand.

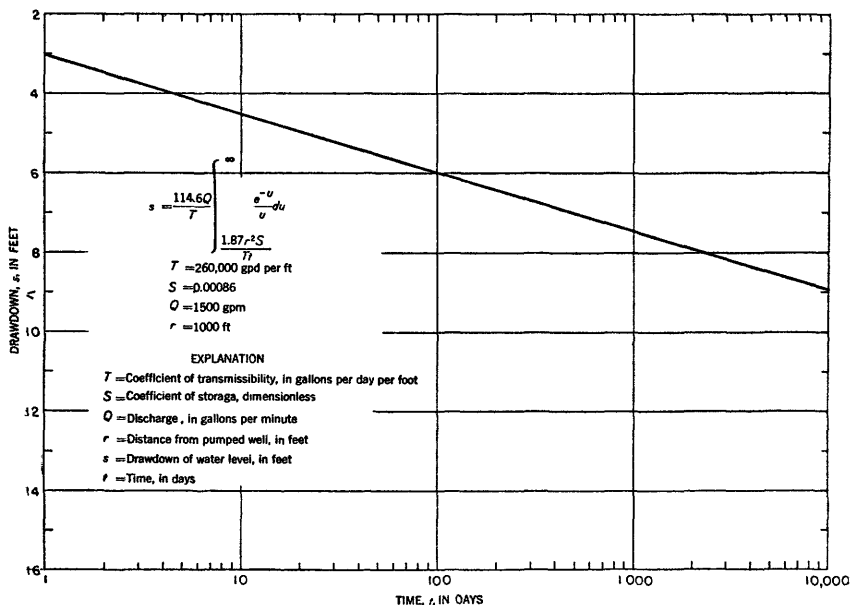

FIGURE 13.—Theoretical time-drawdown relationship in an infinite aquifer having the hydraulic characteristics determined for the "200-foot" sand.

water averages about 72°F. The chloride content of water from this sand is generally less than 100 ppm, except in the eastern part of the parish where it is as much as 300 ppm and the dissolved solids are as high as 700 ppm. (See analyses for wells Cu-347, Cu-640, and Cu-642.)

#### "500-FOOT" SAND

*Distribution and thickness.*—The "500-foot" sand is the principal aquifer in Calcasieu Parish. Its distribution throughout the parish is illustrated by cross sections *A-A'* and *B-B'* (pl. 4) and the fence diagram (pl. 3). The aquifer has a maximum thickness of 310 feet in the north-central part of the parish, as shown by the log of well 13 on plate 4, and a minimum thickness of about 25 feet in the southeast corner of the parish, as shown by well 26 on plate 3. The variation in thickness throughout the parish is shown by isopach contours on plate 7. The exact correlation of the "500-foot" sand northward from Sulphur to the parish line is tentative, owing to the irregularity of the beds and a lack of adequate subsurface information. In the southwest corner of Calcasieu Parish, the "500-foot" sand is between the depths of 590 and 750 feet; at Vinton it is between the depths of 410 and 600 feet and contains a clay layer between 470 and 500 feet. Within the industrial district the sand is about 170 feet thick between the depths of 390 and 560 feet in well Cu-74, and 200 feet thick (including a 10-foot clay bed) between the depths of 330 and 530 feet in well 16 (pl. 4). At well 1

(pl. 4), in the vicinity of DeQuincy, the "500-foot" sand is about 195 feet thick between the depths of 165 and 360 feet, and at Iowa, in the eastern part of the parish, it lies between the depths of 440 and 500 feet. (See well 20, pl. 4.)

Southwest of the industrial district, at well Cu-453, there is a sand between the depths of about 170 and 345 feet which appears to be of local extent; however, a study of water levels measured in this well indicates that it is hydrologically connected with the "500-foot" sand.

The "500-foot" sand dips southward from the outcrop area in central Beauregard and Allen Parishes at an average rate of 18 feet per mile. North of the industrial district, the average rate of dip is 18 feet per mile, whereas south of this area it increases to about 40 feet per mile. Locally the dip may vary considerably, owing to the unevenness of both the top and the bottom of the aquifer.

The material composing the "500-foot" sand is gray to brownish and usually ranges from fine sand at the top to coarse sand and gravel near the base. Results of the mechanical analyses made of sand samples from the "500-foot" sand are shown on figure 14.

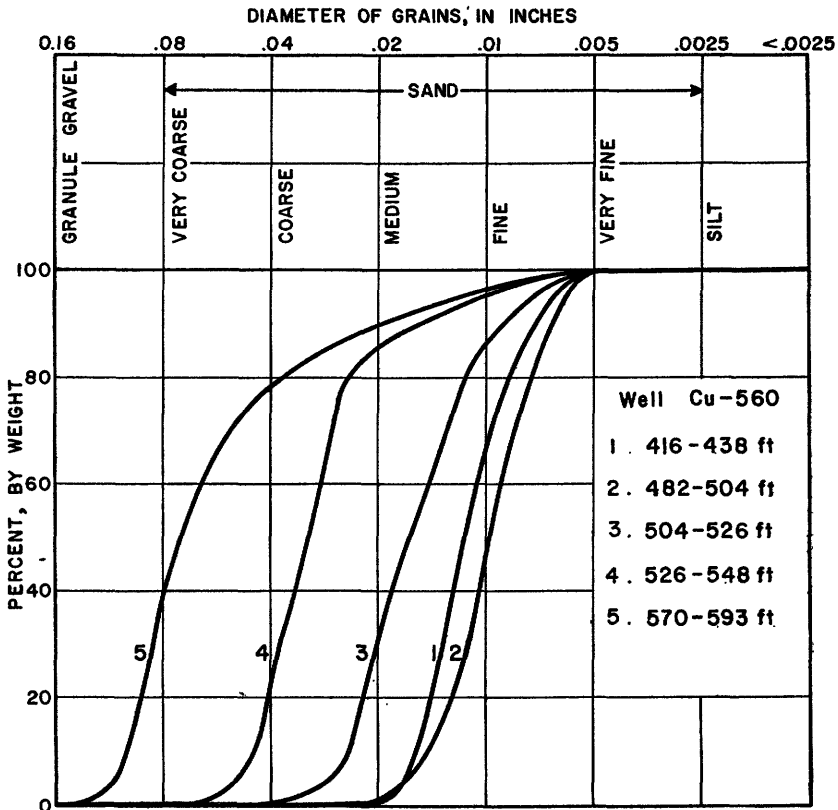

FIGURE 14.—Cumulative curves showing grain size of materials from the "500-foot" sand.

The sand consists dominantly of subangular quartz grains (a few iron-stained) and some dark minerals. The gravel is composed mostly of chert pebbles. Chunks of carbonized wood are often found in drill cuttings from layers where large logs were deposited with the sand and gravel. (See driller's log of well Cu-653 in table 8.)

*Hydrology.*—The "500-foot" sand is the most heavily developed aquifer in Calcasieu Parish. (See table 5.) It supplies water to the towns of Sulphur, Edgerly, and Vinton, La., and Orange, Tex.; to a large number of irrigation wells in the area; and to most of the industries. The amount of water withdrawn from the "500-foot" sand for each use in 1955 is given in table 5. The "500-foot" sand is not utilized to a large extent as a source of supply in the southeastern part of the parish, where it is relatively thin and consists of fine sand.

Reported yields from industrial wells screened in the "500-foot" sand range from 600 to 2,000 gpm. The reported specific capacities of industrial wells range from about 6 to 75 gpm per foot of draw-down and average 40. Irrigation wells, pumped to open discharge generally have greater yields than industrial wells. For example, the measured yields from two irrigation wells, Cu-635 and Cu-639, were 3,800 and 2,500 gpm, respectively.

The hydraulic characteristics of the "500-foot" sand were determined by pumping tests made at six separate sites using existing industrial and irrigation wells. The values of the coefficients of transmissibility, storage, and permeability are given in table 2. In the industrial district the average values determined are coefficient of transmissibility, 190,000 gpd per foot; coefficient of storage, 0.00054; and coefficient of permeability, about 1,200 gpd per square foot. The permeability of the "500-foot" sand in the northern part of the parish as determined from a test made at well Be-359 (about half a mile northeast of well Cu-208) is about 2,000 gpd per square foot (table 2), whereas to the south in the vicinity of the Calcasieu-Cameron Parish boundary the permeability decreased to about 1,000 gpd per square foot. (See results of tests of wells Cu-263 and Cu-59 in table 2). This variation in permeability is due to textural changes within the "500-foot" sand from south to north, where the coarser materials predominate. The average coefficient of transmissibility determined from pumping tests for the "500-foot" sand in Calcasieu Parish is 200,000 gpd per foot, which compares reasonably well with that (300,000 gpd per foot) determined from a geometric analysis of piezometric maps (Jones and others, 1954, p. 149).

On the basis of the assumptions that the aquifer is homogeneous, infinite in areal extent, and without lateral boundaries, and making

use of the above-mentioned coefficient of transmissibility of 200,000 gpd per foot and an average storage coefficient of 0.00054, the curves in figures 15 and 16 were prepared. The graph in figure 16 shows that after 1 year of continuous pumping at 1,500 gpm water

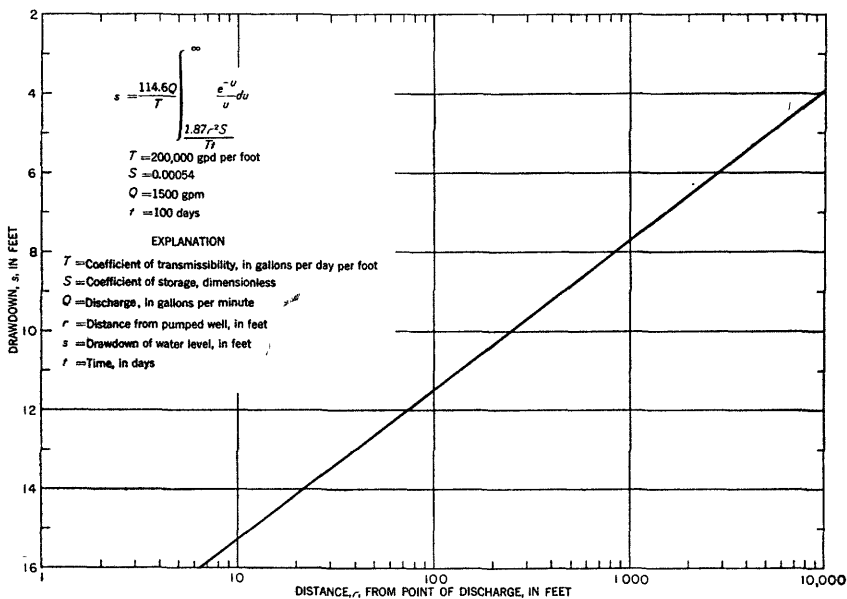

FIGURE 15.—Theoretical distance-drawdown relationship in an infinite aquifer having the hydraulic characteristics determined for the "500-foot" sand.

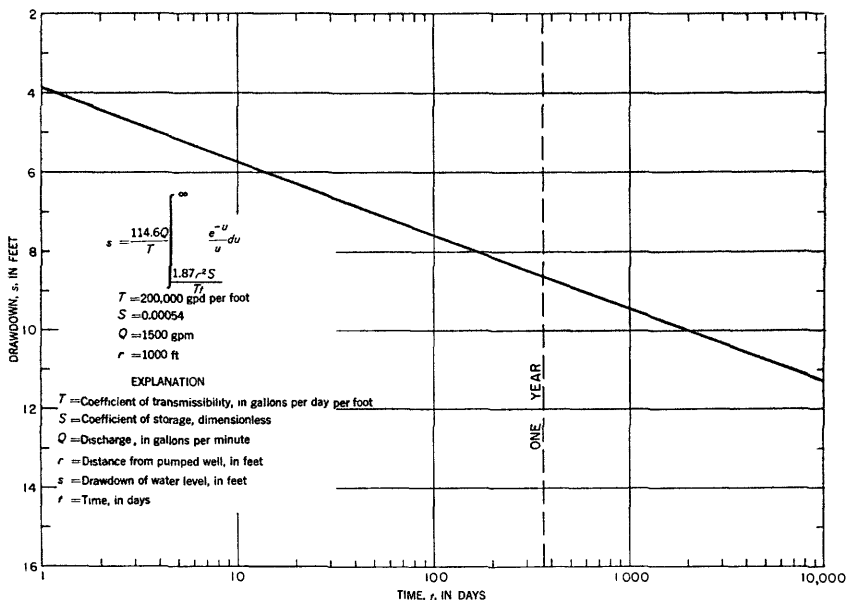

FIGURE 16.—Theoretical time-drawdown relationship in an infinite aquifer having the hydraulic characteristics determined for the "500-foot" sand.

levels at a distance of 1,000 feet from the pumping well would decline about 9 feet.

*Quality of water.*—Chemical analyses of water from wells screened in the "500-foot" sand (table 7) show the water to be moderately hard and to have a pH range from 6.7 to 8.6. The average of dissolved solids is 302 ppm and the chloride content is generally low in the northern and central parts of the parish where the average is about 30 ppm. Immediately south of the parish line in Cameron Parish, several irrigation wells yield water having a chloride content of 300 to 500 ppm. However, water samples collected in the southern part of Calcasieu Parish show no widespread salt-water contamination. Concentrations of chloride of more than 600 ppm are found locally above salt dome structures. (See analyses for well Cu-585 in table 7.) The total iron content ranges from 0.04 to 11 ppm, and the average for 28 samples (table 7) is 2.3 ppm. The temperature of the water averages 74°F.

#### "700-FOOT" SAND

*Distribution and thickness.*—The "700-foot" sand supplies water to industries and irrigators and is the source for public supply at Lake Charles. (See table 5.) The sand is at a depth of about 700 feet in the industrial district near Lake Charles. As shown by the fence diagram and the cross sections (pls. 3 and 4), the "700-foot" sand is rather thick and is continuous throughout the parish. In several places, clay layers divide the aquifer into two or three separate layers; however, because the clay layers are not continuous, the sands are considered to be hydrologically connected. The aquifer has a total thickness of 220 feet in the industrial district. (See well 7, pl. 4.) It is about 205 feet thick in the eastern part of the parish (see well 20, pl. 4), 90 feet thick in the western part of the parish (see well 16, pl. 3; well 11, pl. 4), and 60 feet thick in the vicinity of DeQuincy in the northern part of the parish (see well 1, pl. 4).

The regional dip of the sand between wells 1 and 10 on plate 4 is southward at about 10 feet per mile. The dip varies greatly, as shown by cross section A-A' (pl. 4) and by the contours drawn on the top of the "700-foot" sand shown on plate 8. In the central part of the parish, the dip is nearly flat as far south as the Sulphur mines in the vicinity of Sulphur, whereas in the area due south of Sulphur it increases to about 10 feet per mile. In the vicinity of Moss Lake, the rate of the southward dip increases to 50 feet per mile.

The "700-foot" sand is generally tan to grayish and grades from fine at the top to coarse at the bottom, as shown by the cumulative curves in figure 17. The grains are less iron stained and generally



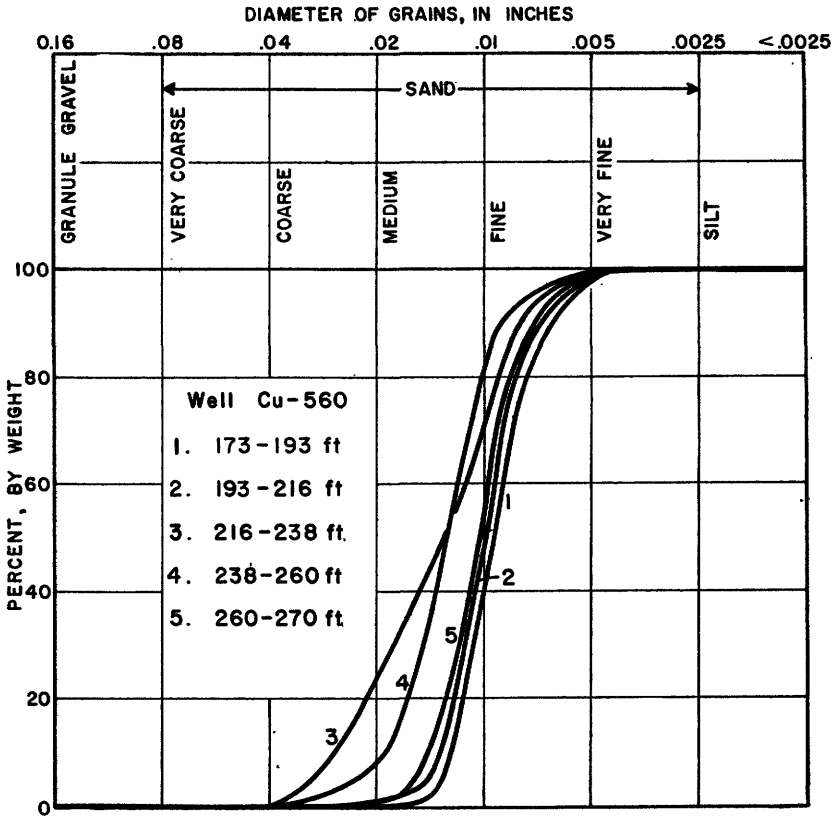

FIGURE 17.—Cumulative curves showing grain size of materials from the “700-foot” sand.

better rounded and finer than those in the “500-foot” sand.

*Hydrology.*—In 1955 there were eight large-capacity industrial wells screened in the “700-foot” sand. The city of Lake Charles derives its entire municipal water supply from six wells screened in this sand. The reported original yields from the municipal wells were about 1,200 gpm, and their reported specific capacities about 32 gpm per foot of drawdown. The reported yields of 15 industrial wells ranged from 800 to 2,200 gpm and averaged 1,500 gpm. The average specific capacity of 7 of these wells was 30 gpm per foot of drawdown.

Values of the coefficients of transmissibility and storage were determined in 1942 from wells owned by the Greater Lake Charles Water Co. (formerly Gulf States Utilities Co.). The average coefficient of transmissibility is about 180,000 gpd per foot, the average coefficient of storage is 0.0006, and the average permeability is 1,200 gpd per square foot.

The distance-drawdown and time-drawdown curves in figures 18 and 19 are based on coefficients of transmissibility and storage of

80,000 gpd per foot and 0.0006, respectively. As shown by the distance-drawdown curve (fig. 18), the drawdown in an observation well 1,000 feet from a well pumped at 1,000 gpm continuously for 10 days will be about 4 feet. The time-drawdown curve (fig. 19)

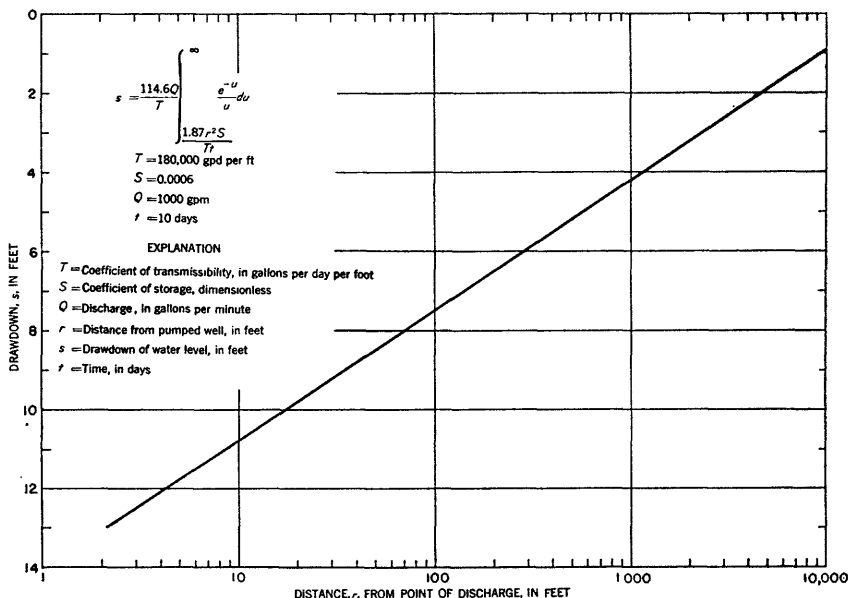

FIGURE 18.—Theoretical distance-drawdown relationship in an infinite aquifer having the hydraulic characteristics determined for the "700-foot" sand.

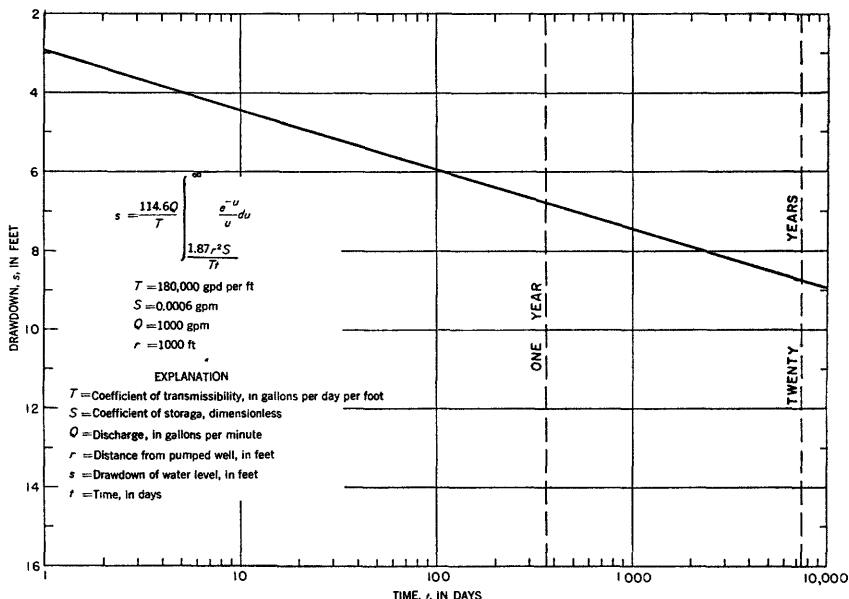

FIGURE 19.—Theoretical time-drawdown relationship in an infinite aquifer having the hydraulic characteristics determined for the "700-foot" sand.

shows that the drawdown in an observation well 1,000 feet from a well pumped at 1,000 gpm will be about 7 feet after 1 year of continuous pumping and that if pumped continuously for 20 years about 50 percent of the total drawdown will have occurred 10 days after the start of pumping.

*Quality of water.*—Chemical analyses of water from wells screened in the “700-foot” sand are given in table 7. Wells screened in this sand generally yield a moderately hard water that has a greater sodium-to-calcium ratio than that from the “500-foot” sand. The iron content averages about 3.2 ppm, and the temperature ranges from 74° to 78°F. Generally the chloride content of water in the “700-foot” sand is greater than that in the “200-” and “500-foot” sands. The curves in figure 20 indicate that there apparently has been no salt-water contamination of well Cu-463, which is screened in the “500-foot” sand in the industrial district, whereas the chloride content of water from well Cu-462, screened in the “700-foot” sand, has increased from about 25 ppm in 1950 to 220 ppm in 1955. Moreover, the chloride content in another nearby well screened in the “700-foot” sand (well Cu-96, fig. 20) had increased to 450 ppm when it was abandoned in 1951. The chloride content of the water from public-supply well Cu-3 had increased from 91 ppm in 1940 to 156 ppm in 1956. Well Cu-661, the most recently installed municipal-supply well in the southern part of the city of Lake Charles, yielded water having a chloride content of 88 ppm in September 1956. The chloride content of water from well Cu-151, an irrigation well screened in the “700-foot” sand in the southeastern part of the parish, was 316 ppm in 1955. The reason for the higher chloride content of water from these wells in the central and southern parts of the parish may be due to incomplete flushing of the “700-foot” sand by fresh water. In the northern part of the parish, the chloride content is less than 30 ppm (see analyses for wells Cu-7 and Cu-495 in table 7) and current records do not show any effects of salt-water encroachment.

#### DEPOSITS OF PLIOCENE AGE

##### EVANGELINE AQUIFER

*Distribution and thickness.*—The Evangeline aquifer is composed of sedimentary rocks of Pliocene age which occur throughout southwestern Louisiana. This aquifer is near the surface in northern Beauregard, Allen, and Evangeline Parishes, where it is overlain by a thin veneer of Pleistocene deposits (Jones and others, 1954, p. 57). In Calcasieu Parish it is difficult to identify accurately the top of the deposits of Pliocene age, as they bear a marked similarity to the overlying deposits of Pleistocene age. However, on the basis

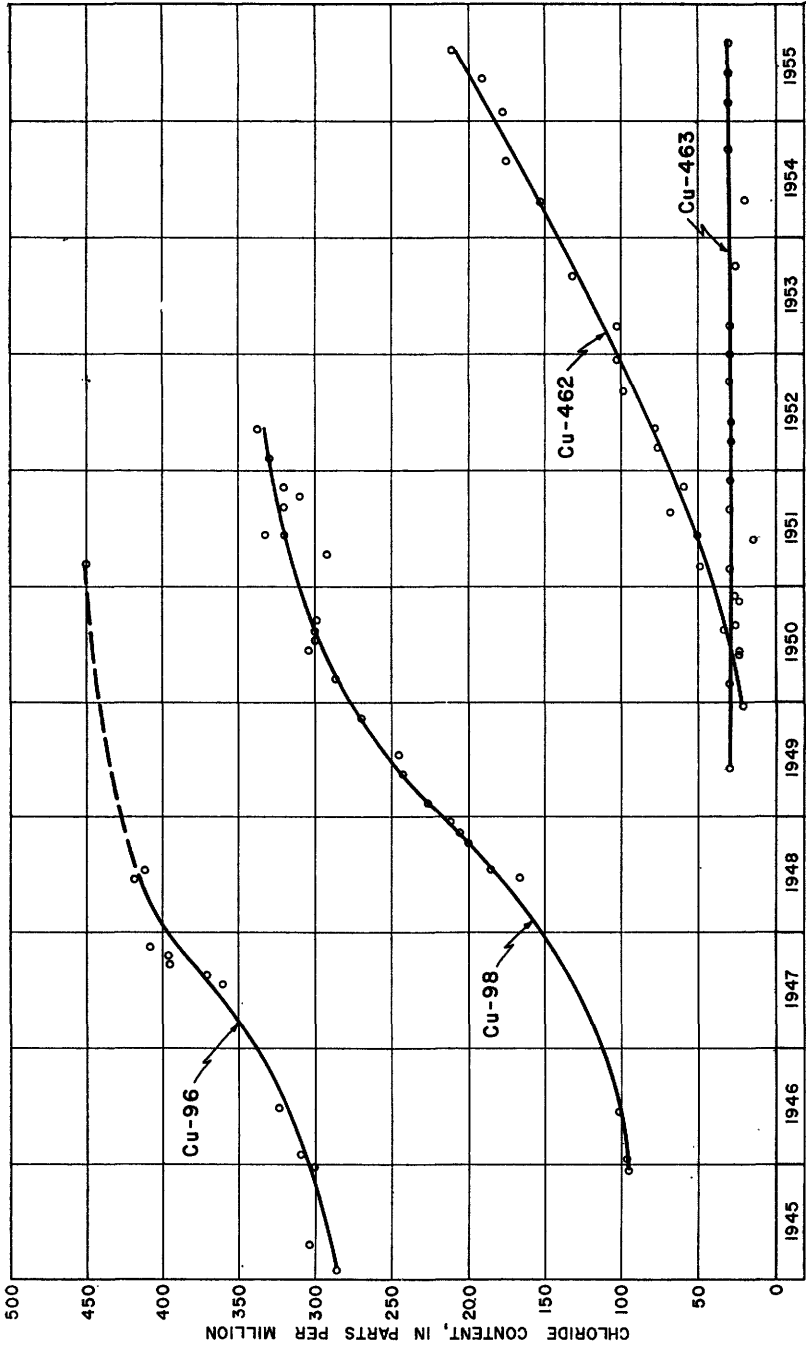

FIGURE 20.—Graph showing the chloride content of water from wells Cu-96, Cu-98, Cu-462, and Cu-463.

of changes in color and texture of the sediment (Jones and others, 1954, p. 69), the top of the Evangeline aquifer which is in the Foley formation, has been delineated and is shown in the geologic sections (pl. 4). In Allen and Evangeline Parishes, where several wells have penetrated the Evangeline aquifer, the sand generally is fine to medium grained. There is a considerable variation in the thickness of individual sand beds in the Evangeline aquifer. At DeRidder, in Beauregard Parish, 18 beds of sand in the lower part of the aquifer, between depths of 300 and 1,000 feet, range from 3 to 115 feet in thickness and average 27 feet (Jones and others, 1954, p. 130). Generally, the individual sand beds are discontinuous; however, it appears that each sand bed is connected either above, below, or laterally with other beds, thus forming a single hydrologic unit (Jones and others, 1954, p. 130). The Evangeline aquifer is about 1,000 feet thick in the vicinity of DeQuincy, where it contains fresh water. Southward, in the industrial district, it contains salt water throughout its entire thickness of about 2,000 feet.

*Hydrology.*—The permeability of the sands in the Evangeline aquifer (estimated to be 250 to 1,000 gpd per square foot) is generally lower than that in the overlying Chicot aquifer, as would be expected considering the finer grain of the materials making up these sands (Jones and others, 1954, p. 131). The specific capacity of 10 wells tapping the Evangeline aquifer in southwestern Louisiana ranged from 2 to 20 gpm per foot of drawdown, as compared to the average specific capacities of 24 to 40 gpm per foot of drawdown of wells in the Chicot aquifer. A test well (Cu-666) was drilled to a depth of 2,204 feet and was screened opposite a sand of Pliocene age between depths of 930 and 990 feet. The water level was 49 feet below the land surface, and the yield was 220 gpm—the specific capacity was 2. This is the only well known to have been screened in the Evangeline aquifer in Calcasieu Parish.

*Quality of water.*—In adjoining parishes where the Evangeline aquifer is a source of fresh water, the water is of the sodium bicarbonate type, very soft, slightly alkaline, low in chloride content, and free of excessive quantities of dissolved iron (Jones and others, 1954, p. 137). Where fresh it is excellent for public supply, although locally it may be yellowish or brownish. This color is probably due to colloidal organic matter, and the water generally is not considered harmful for human consumption.

As shown by data from electrical logs of test wells, the Evangeline aquifer contains salt water in the industrial district. The water from well Cu-666, near the industrial district, contains about 14,000 ppm of chloride; this substantiates data from electrical logs. In the northern part of the parish, the aquifer contains fresh water (having less than 250 ppm of chloride) throughout.

## DEPOSITS OF MIOCENE AGE

Electrical logs of oil-test wells indicate that throughout most of Calcasieu Parish the sands of Miocene age contain salt water. However, according to electrical logs, fresh water occurs in a few thin sands of Miocene age between depths of 1,500 and 2,500 feet in the extreme northern part of the parish. Because no known water wells penetrate these sands in Calcasieu Parish, no information on their water-bearing characteristics is available.

## WITHDRAWALS AND THEIR EFFECTS

## GENERAL CONDITIONS

A total of about 105 mgd (million gallons per day) of water was withdrawn from wells in the principal sands of the Chicot aquifer in Calcasieu Parish in 1955. This estimate of withdrawal is based on ground-water use as reported by industries, measured discharge of some wells, and data supplied by municipalities. Of the 105 mgd pumped, about 66 mgd was used by industries, 27 mgd by irrigators, 8 mgd by municipalities, and 4 mgd for rural supplies. Of the 101 wells listed in table 6 as industrial-supply wells, 40 are for oil-field supply. Wells used for supply during drilling operations are temporary, and the present (1956) estimated pumpage from these wells is 0.25 mgd. This small amount is not listed in the total withdrawals in table 5.

Since 1955, rice has been included under the Federal price-support program. In Calcasieu Parish this program has resulted in a decline in rice acreage from an average of 77,000 acres a year during 1945-54 to about 63,000 acres a year during 1955-56. However, this decrease in acreage has not resulted in a significant decline in the amount of ground water used for irrigation. It appears that the total amount of water pumped is affected more directly by the amount of rain during the growing season than by the change in acreage planted. It is probable, however, that a continued decline in the acreage of rice will result in a general reduction in the amount of ground water pumped for irrigation. The relation of rainfall to pumpage for irrigation purposes from the Chicot aquifer

TABLE 5.—Ground-water pumpage, in thousand gallons per day, in Calcasieu Parish in 1955

Source	Municipal	Industrial	Irrigation	Rural	Total	Percent of total
"200-foot" sand.....	150	3,000	7,860	(?)	11,010	10.5
"500-foot" sand.....	1,700	50,700	17,000	(?)	69,400	66.0
"700-foot" sand.....	6,000	12,300	2,500	(?)	20,800	19.7
All sands (undifferentiated).....				4,000	4,000	3.8
Total.....	7,850	66,000	27,360	4,000	105,210	-----
Percent of total.....	7.5	62.7	26.0	3.8	-----	100

is shown in figure 21. The graph shows that pumping for irrigation generally is inversely related to rainfall during the rice-growing season. A comparison of rainfall and pumping for rice irrigation for 1954 and 1955 clearly illustrates this relationship. In 1954, when there was a total rainfall of 13.5 inches during the rice-growing season, about 53,000 acre-feet was pumped; in 1955 there was a total rainfall of 31 inches during the rice-growing season, and pumpage decreased to about 31,000 acre-feet. In 1954, moreover, 84,000 acres of rice was irrigated by 53,000 acre-feet of ground water, and in 1956 only 58,200 acres was irrigated, but the amount of ground water used increased to about 57,500 acre-feet. The rainfall during the rice-growing season in 1956 was 12.71 inches. The poor correlation for the years 1952 and 1953 is due to exceptionally heavy rains occurring within short periods of time during the rice-growing season. Because ground-water levels are directly affected by pumping, they declined rapidly during 1948 and 1951 (fig. 22) when rainfall during the growing season was below normal.

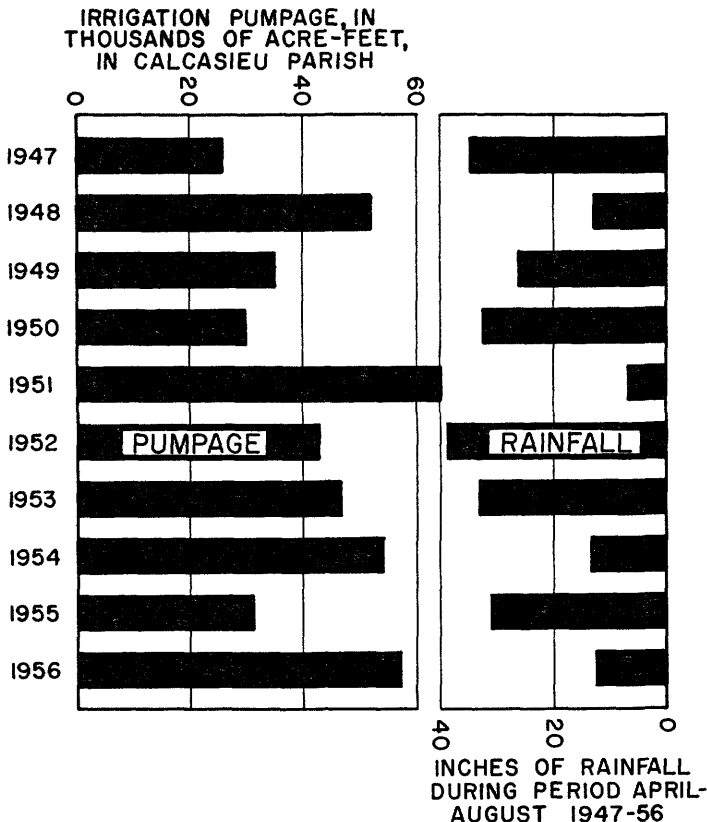

FIGURE 21.—Graph showing the relation between pumpage from the Chicot aquifer and rainfall during the rice-growing season.

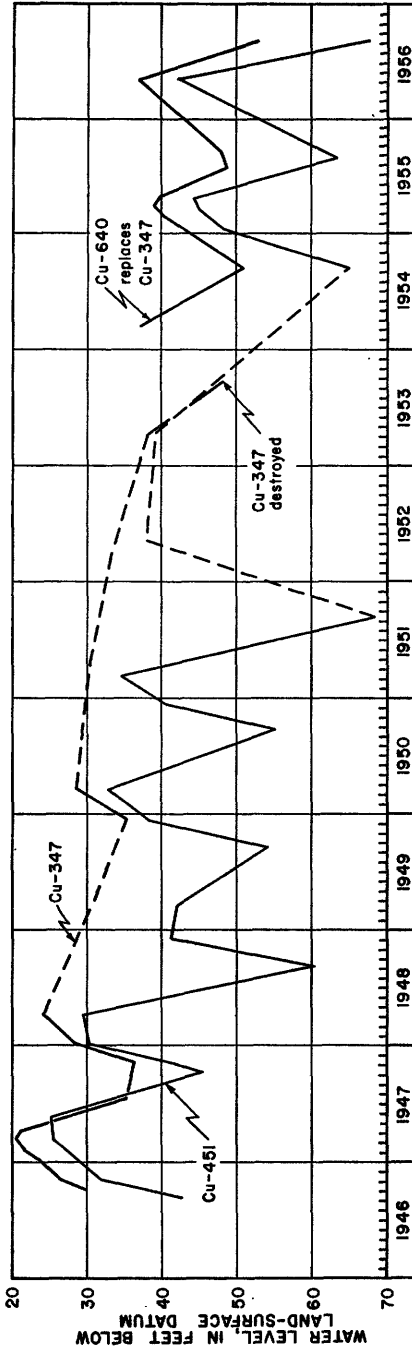

FIGURE 22.—Hydrographs of wells screened in the "200-foot" sand.



The quantity of water used from the Chicot aquifer for rural needs is based on an estimated per capita use of 125 gpd (Jones and others, 1954, p. 204) and a rural population of 32,133 (1950 census). This allows for gardening and stock supply and use by small businesses. It is reasonable to assume that practically all the water required for rural supplies is obtained from wells because of the availability and easy accessibility of a potable ground-water supply. All municipalities in Calcasieu Parish are dependent upon wells that tap the Chicot aquifer.

Practically all the ground water pumped in Calcasieu Parish is removed permanently from the aquifers. Water used is discharged into a network of drainage canals and streams which eventually flow to the Gulf of Mexico. There may be, and probably is, some local influent seepage from streams, and such recharge may include small quantities of used ground water. However, this amount is probably negligible and is not considered in the overall computation of ground-water use.

The concentration of pumping in the industrial district has resulted in this area having the lowest water levels in the Chicot aquifer in southwestern Louisiana. In the central part of this district the greatest water-level decline, to slightly more than 100 feet below sea level, has been in the "500-foot" sand. The average annual water-level decline in southwestern Louisiana is about 1 foot (Fader, 1957), whereas the present average annual decline in the principal sands in Calcasieu Parish is as great as 3.5 feet.

#### CHICOT AQUIFER

##### "200-FOOT" SAND

##### PUMPAGE

The first recorded well near Lake Charles in the "200-foot" sand was a drilled industrial well constructed prior to 1903 and was known as Reiser's Machine Shop well. It is reported that the altitude of this well was about 13 feet and that the well was known to flow to 17 feet above the land surface in 1903 (Harris and others, 1905, p. 59). The first large-capacity industrial well in this sand was constructed in 1940 near Westlake, La. Available records indicate that the "200-foot" sand supplied water to the first irrigation wells in the parish which were drilled about 1900 (Harris and others, 1905, p. 55-59). In the "200-foot" sand there are presently three large-capacity industrial wells in the vicinity of Westlake (pl. 2), in addition to public-supply and many irrigation wells in the southeastern part of the parish.

Withdrawals from the "200-foot" sand have gradually increased from little or nothing in 1900 to an average of about 11 mgd in 1955 (table 5). In 1955 the sand supplied 0.15 mgd for municipal purposes, principally at Iowa; 3.0 mgd for industrial purposes in the vicinity of Westlake; and 7.9 mgd for irrigation, principally in that part of the parish east of the Calcasieu River.

#### EFFECTS OF PUMPING

Water-level measurements made in wells screened in the "200-foot" sand are shown graphically on figure 25 and are reported in table 6. The measured water level in well Cu-45, in the city of Lake Charles, was 27.15 feet below the land surface on January 20, 1943, and 53.44 feet below land surface on March 18, 1956 (table 6); this decline of 26.29 feet during the 13-year period averages 2 feet per year. Southeast of Lake Charles, near Holmwood, the average yearly decline in well Cu-451 was 2 feet for the period 1947 to 1956 (fig. 22). The net water-level declines are computed from measurements made in the spring prior to the beginning of rice irrigation, as those measurements indicate more accurately the level of maximum recovery for the year. Since 1946 the average annual water-level decline has been less than 2 feet (see graphs for wells Cu-347 and Cu-640 on fig. 22) in the eastern part of the parish, where the "200-foot" sand is the principal source of water for domestic, agricultural, and municipal purposes. The water-level decline in well Cu-45 is closely representative of wells in the industrial district. Because of a pronounced decrease in the use of water for rice irrigation during 1955, the water levels showed a net recovery of as much as 3 feet from the spring of 1955 to the spring of 1956.

#### "500-FOOT" SAND

##### PUMPAGE

The first recorded drilled well in the "500-foot" sand was an industrial well 6 inches in diameter, owned by the Bradley and Ramsey Lumber Co. in Lake Charles. In 1903 this well had the largest natural flow (210 gpm) of any well in the State (Harris and others, 1905, p. 58). It is estimated that the static water levels in the "500-foot" sand in 1903 were about 20 feet above sea level. In 1934 pumpage from this sand was relatively small, and most of the wells flowed when completed. After the industrial expansion of the Lake Charles area (1934), pumpage gradually increased from a negligible amount in 1934 to 69.4 mgd in 1955, of which about 50.7 mgd (see table 5) was withdrawn from the "500-foot" sand for industrial purposes in Calcasieu Parish.

#### EFFECTS OF PUMPING

*Water levels.*—Throughout the parish, water levels in the "500-foot" sand have declined steadily during the period of record. In

the area outside the industrial district, they declined at an average rate of about 2 feet per year during 1943-56, as shown by the hydrographs of wells Cu-115, Cu-120, Cu-208, and Cu-228 (fig. 23). The wells outside the area of heavy industrial and public-supply pumping reflect the regional water-level trend and seasonal declines caused by pumping for rice irrigation. The result of decreased seasonal pumping for rice irrigation in 1955 is shown graphically in figure 23; the 1956 spring water levels were higher than those measured the previous spring. The net water-level recovery in these wells for the year ranged from 2 to 4 feet.

In the industrial district, water levels declined at an average rate of about 1.4 feet per year during 1903-56; however, since 1934, when industrial development started on a large scale, water levels have declined at the average rate of about 2.9 feet per year. The average declines were based upon reported levels in 1903 and 1934 and measured levels in well Cu-22 (fig. 24) since 1943. This well is within the industrial district but in an area where the levels are not affected by nearby heavy pumping. The 1956 spring water levels in this well are about 3 feet below that measured in the spring of 1955. This suggests that the water-level fluctuations in well Cu-22 are caused primarily by variations in local industrial pumping.

The hydrograph (fig. 25) of water levels measured in well Cu-445 in the industrial district shows an average annual decline of about .5 feet during 1946-56. As shown in figure 25, the average daily municipal and industrial pumpage from the "500-foot" sand in the industrial district and adjoining communities in 1945 was 21 mgd, and in 1956 it was 53 mgd, representing an increase of 150 percent. The hydrograph of well Cu-445 reflects this increased pumping. The annual fluctuation, starting with a decline in the spring and ending with a recovery in the fall, is due to changes in industrial use as well as seasonal pumping for agricultural purposes.

Although the present decline of water levels in the areas of heavy pumping is relatively large, as compared to that in the other sands, it is not excessive and must be expected in order to provide a gradient sufficient to move the required amount of water into the areas of pumping. A wider spacing of wells, as new ones are drilled to replace old wells, would minimize the amount of interference between them. Moreover, if the total pumpage is not increased, wider spacing of wells will result in a decrease in the rate of water-level decline in the industrial district.

*Analysis of piezometric map.*—Calcasieu Parish is included in the area covered by piezometric maps for the year 1903 and the period 1944-51 in two recent reports, one (Jones and others, 1954) pub-

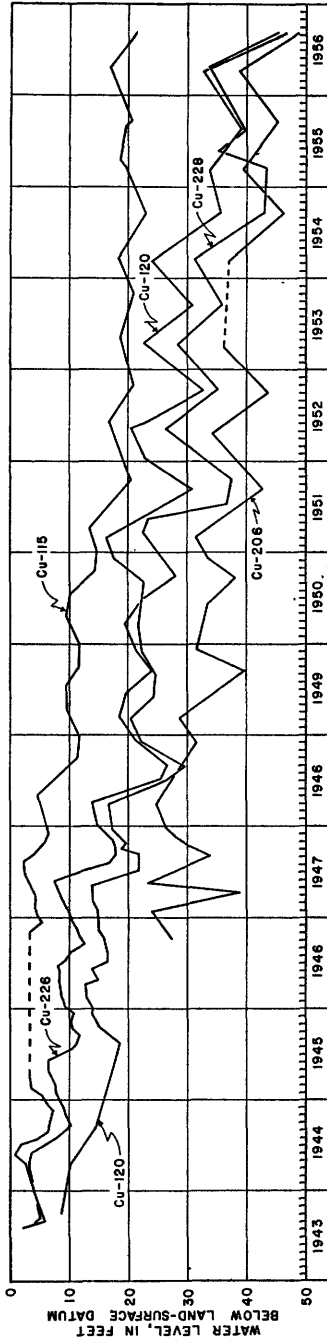

FIGURE 23.—Hydrographs of wells screened in the "500-foot" sand outside the industrial district.

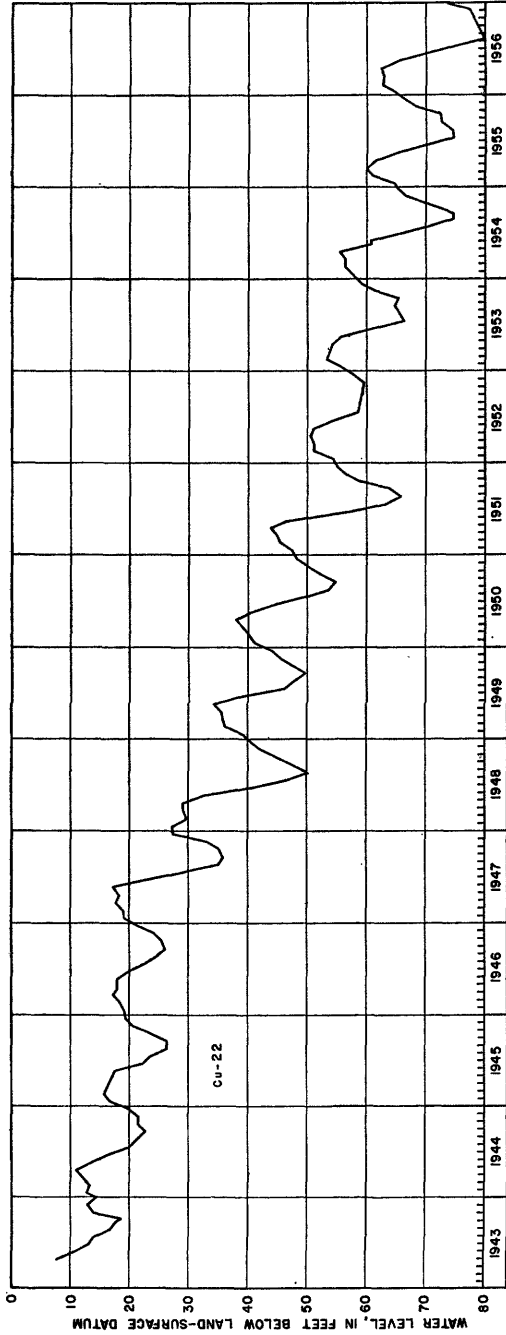

FIGURE 24.—Hydrograph of well Cu-22 screened in the "500-foot" sand in the industrial district.

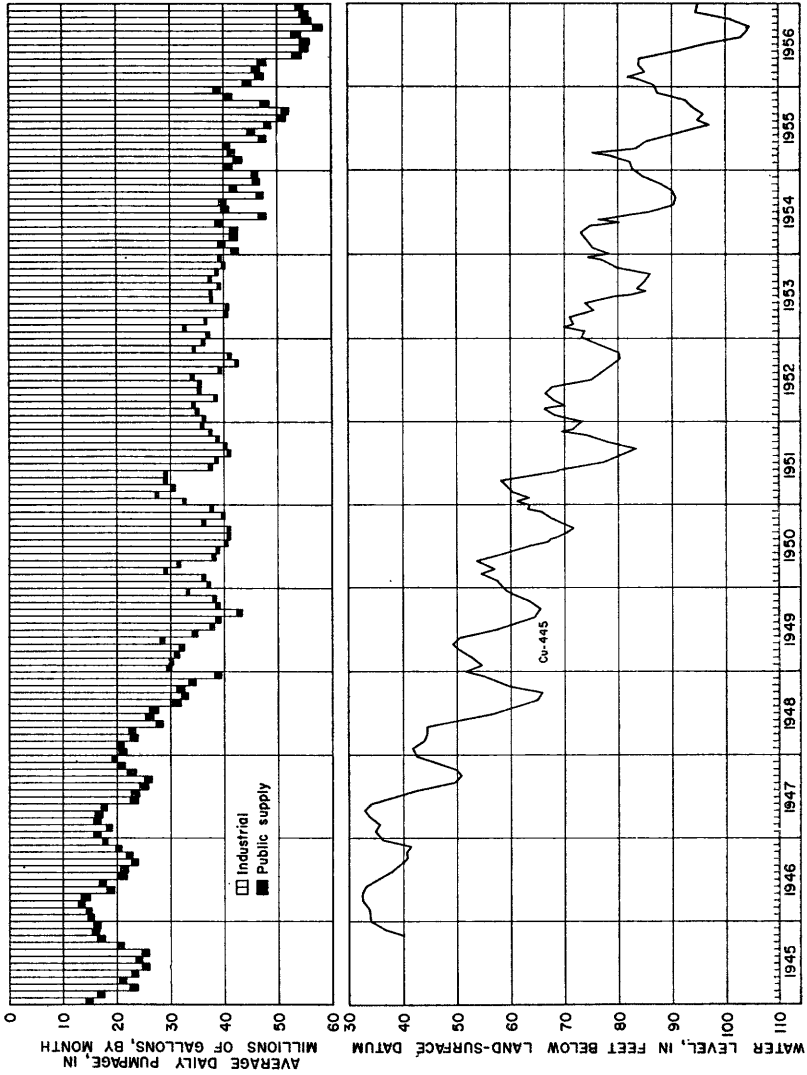

FIGURE 25.—Graph showing the relation of water levels in a well to pumpage from the "500-foot" sand in the industrial district,

lished by the Louisiana Geological Survey and the other (Jones and others, 1956) published by the U.S. Geological Survey. Maps for the period 1952-55 are included in three reports published by the Louisiana Geological Survey, Department of Conservation, and the Louisiana Department of Public Works (Fader, 1954, 1955, and 1957). Piezometric maps of the "500-foot" sand in Calcasieu Parish for the months of September 1943, October 1946, and September 1949 are included in an open-file report issued in 1950 (Jones).

A piezometric map of the "500-foot" sand was prepared for this report from water-level measurements made during September 1955. (See pl. 5.) Contour lines connecting points of equal water-surface elevation in wells used as control points show the altitude to which water rose in wells screened in the "500-foot" sand. Water-level-contour (piezometric) maps indicate, directly or indirectly, the direction of ground-water flow, areas of recharge and discharge, ground-water divides, water levels with reference to a known datum, and effects of pumping; and when used with other hydrologic data, they show the rate of movement. Moreover, by comparing successive maps, changes in ground-water storage may be computed.

The direction of flow of ground water is downgradient along flow lines—lines crossing all contours at right angles. The direction of movement of the water in the "500-foot" sand in Calcasieu Parish is toward areas of heavy pumping. This is in contrast to conditions in 1903, when there was little or no pumping and the direction of movement throughout the parish was southward (Jones and others, 1954, pl. 17).

Pumping tests on both industrial and irrigation wells were made at six separate sites. One purpose of the tests was to determine the hydraulic characteristics of the aquifer so that the effect of withdrawals of water could be predicted.

The transmissibility of an aquifer determined by pumping tests can be verified by comparing the quantity of water pumped from an area with the quantity of water moving into the area as calculated by Darcy's law and data from the piezometric map. Darcy's law is expressed as—

$$Q = PIA \quad (2)$$

where—

$Q$  is quantity of discharge per unit time

$P$  is permeability

$I$  is hydraulic gradient

$A$  is cross-sectional area through which water percolates.

This equation can be rewritten by substitution in the following manner:

$$Q = \frac{T}{m} I(Lm) = TIL \quad (3)$$

where—

$$P = \frac{T}{m}$$

$T$  is transmissibility

$A$  is  $Lm$

$L$  is length, normal to direction of flow, of the section through which the water moves

$m$  is thickness of aquifer.

The hydraulic gradient between the contour lines is given by the formula

$$I = \frac{c}{d} = \frac{c}{B/L} = \frac{cL}{B} \quad (4)$$

where—

$c$  is contour interval

$d$  is average distance between contours

$B$  is area between contours

$d$  is  $\frac{B}{L}$ .

By substituting equation 4 into equation 3 the expression may be written—

$$Q = T \times \frac{cL}{B} \times L = \frac{TcL^2}{B} \quad (5)$$

where—

$Q$  is expressed in gallons per day

$T$  is in gallons per day per foot

$c$  is in feet

$L$  is in miles

$B$  is in square miles

By use of formula 5 and data from the piezometric map, the amount of water flowing across the —60- and —70-foot contour lines (pl. 5) in the vicinity of well Cu-445 can be calculated as follows:

$$Q = \frac{190,000 \times 10 \times (13.25)^2}{18.4} = 18,000,000 \text{ gallons per day flowing across the —70 foot contour}$$

when—

$T$  is average coefficient of transmissibility of the "500-foot" sand in the industrial district = 190,000 gpd per ft

$L$  is calculated length and equals  $(17.75 + 8.75) \div 2 = 13.25$  miles; where the length of the —60-foot contour around well Cu-445 = 17.75 miles and the length of the —70-foot contour around well Cu-445 equals 8.75 miles

$B$  is area between the —60- and —70-foot contours and equals 18.4 square miles; where the area encompassed by the —60-foot contour equals 24.4 square miles and the area encompassed by the —70-foot contour equals 6.0 square miles

$c$  is contour interval and equals 10 feet.



The reported total pumpage from the "500-foot" sand within this area is 20.5 mgd, which results in a difference of only 12 percent from that calculated (18.1 mgd). A similar analysis made of the amount moving across the -70-foot contour in the vicinity of well Cu-77 shows that, when the transmissibility  $T$  equals 160,000 gpd per foot (table 2), about 36 mgd flows across the -70-foot contour toward the area where about 32 mgd is being pumped from the "500-foot" sand. The difference between the actual and calculated values is 14 percent. The relatively close agreement of the amount pumped and the calculated amount moving into the areas verifies the values of transmissibility determined by pumping tests.

With a coefficient of transmissibility based on an average permeability and thickness of the "500-foot" sand in the area being considered, the amount and rate of water moving northward into the area encompassed by  $A$ ,  $B$ ,  $C$ , and  $D$  (pl. 5) were calculated by formulas 5 and 6 as follows:

$$Q = \frac{TcL^2}{B} = \frac{150,000 \times 10 \times 12^2}{46.9 \times 7.5 \times 10} = 60,000 \text{ cu ft per day (450,000 gpd) per 1-mile length of } -40\text{-foot contour}$$

where—

$L$  is calculated length and equals 12 miles

The length of  $AB$  (-30-foot contour) equals 14 miles

The length of  $CD$  (-40-foot contour) equals 10 miles

$B$  is area encompassed by  $A$ ,  $B$ ,  $C$ , and  $D$  and equals 46.9 sq miles

$c$  is contour interval and equals 10 feet

1 cu ft water equals 7.5 gallons

$T$  is transmissibility and equals 150,000 gpd per foot.

The velocity or rate of movement of water northward between points  $C$  and  $D$  can be calculated as follows:

$$V = \frac{Q \text{ (quantity in cu ft per day)}}{A \text{ (effective area in sq ft)}} \quad (6)$$

thus—

$$V = \frac{60,000}{160,000} = 0.38 \text{ foot per day} = 0.026 \text{ mile per year}$$

where—

$Q = 60,000$  cu ft per day per mile,

$A = 160,000$  sq ft (assuming a porosity of 25 percent and an aquifer thickness of 120 ft, the effective area per mile through which the water moves is  $120 \times 5,280 \times 0.25 = 160,000$  sq ft).

The average distance between the -30- and -40-foot contour lines within the area  $ABCD$  is 3.9 miles. On the basis of the above-calculated velocity, it would therefore require about 150 years for the water to move this distance at the present rate of pumping.

The amount and rate of movement of ground water from the north into the area of heavy pumping was calculated in a similar manner for the area marked *EFGH* (pl. 5), as follows:

$$Q = \frac{TcL^2}{B} = \frac{300,000 \times 10 \times (10.5)^2}{13 \times 7.5 \times 10} = 330,000 \text{ cu ft per day (2,500,000 gpd) per 1-mile length of -40-foot contour between points } E \text{ and } F$$

and—

$$V = \frac{Q}{A} = \frac{330,000}{330,000} = 1 \text{ foot per day} = 0.07 \text{ mile per year}$$

where—

$$A = 250 \times 5,280 \times 0.25.$$

At the above velocity the time required for water to move from the -30-foot contour to the -40-foot contour within the area *EFGH* would be 18 years. The calculated velocities are based on the assumption that the water moves at a uniform rate throughout the thickness of the aquifer.

Within the areas considered the rate of movement southward is about three times that of the rate of movement northward and the quantity entering the area from the north is about six times that from the south where the "500-foot" sand contains salty water.

Piezometric maps may be used to outline areas of heavy pumping and, if the altitude of the land surface is known, to determine the static water level below the land surface in any locality. For example, plate 5 shows the -80-foot contour passing near well Cu-445, where the altitude of the land surface is 12 feet. Consequently, the depth to water in wells penetrating the "500-foot" sand in the vicinity of Cu-445 was 92 feet below the land surface in September 1955. The close relationship between water levels and pumping is shown by comparing the map for September 1955 (pl. 5) with the maps for 1943, 1946, and 1949 presented by Jones (1950, figs. 4, 5, and 6). The areas in which water-level declines were most significant were central and southeastern Calcasieu Parish, which were also areas of heavy pumping. The piezometric surface in the central part of the parish in 1943 was about 25 feet below sea level, whereas in September 1955 it was 100 feet below sea level. In the southeastern part of the parish, the piezometric surface declined from 6 feet below sea level in September 1943 to 30 feet below sea level in 1955.

**"700-FOOT" SAND****PUMPAGE**

The first known wells in the "700-foot" sand, wells Cu-186 and Cu-431 (table 6), were completed in 1918 and are not now in use because water levels have declined below the pump settings. The original yields of the wells and the water levels were not recorded. The first known large-capacity industrial well tapping the "700-foot" sand is Cu-92 near Westlake. This well had a reported yield of 2,200 gpm and a static water level of 21 feet below land surface when drilled in 1942.

As shown in table 5, the "700-foot" sand yields about 6 mgd for municipal supplies, 12.3 mgd for industrial use, and 2.5 mgd for irrigation. In 1956 there were six municipal and eight industrial wells screened in this sand. The average municipal and industrial pumpage in the vicinity of Lake Charles has increased from 4 mgd in 1945 to 17.6 mgd in 1956, or about 300 percent. (See fig. 26.)

**EFFECTS OF PUMPING**

The water level in well Cu-3, in the "700-foot" sand, has declined from 12 feet below the land surface in 1940 (table 6) to 68 feet below the land surface (fig. 27) in January 1956 (the time of maximum recovery), which represents an average annual decline of 3.5 feet for the 16-year period. Well Cu-3 is in the principal public-supply well field in Lake Charles. The hydrograph of well Cu-446 (fig. 26) shows that water levels have declined in the industrial district from about 26 feet below the land surface in April 1946 to 64 feet below the land surface in April 1956, or an average of 3.8 feet per year over the 10-year period. The graph of well Cu-125 (fig. 27) shows that water levels 3 miles southwest of the industrial district have declined from 10 feet below the land surface in April 1944 to 52 feet below in April 1956, or an average annual decline of 3.5 feet per year for the 12-year period. In the rice-farming area southeast of Lake Charles, the average annual decline, based upon records for Cu-173 (fig. 27), has been 2.6 feet since 1947. Thus, the water-level records indicate a general and consistent water-level decline in the "700-foot" sand throughout the parish.

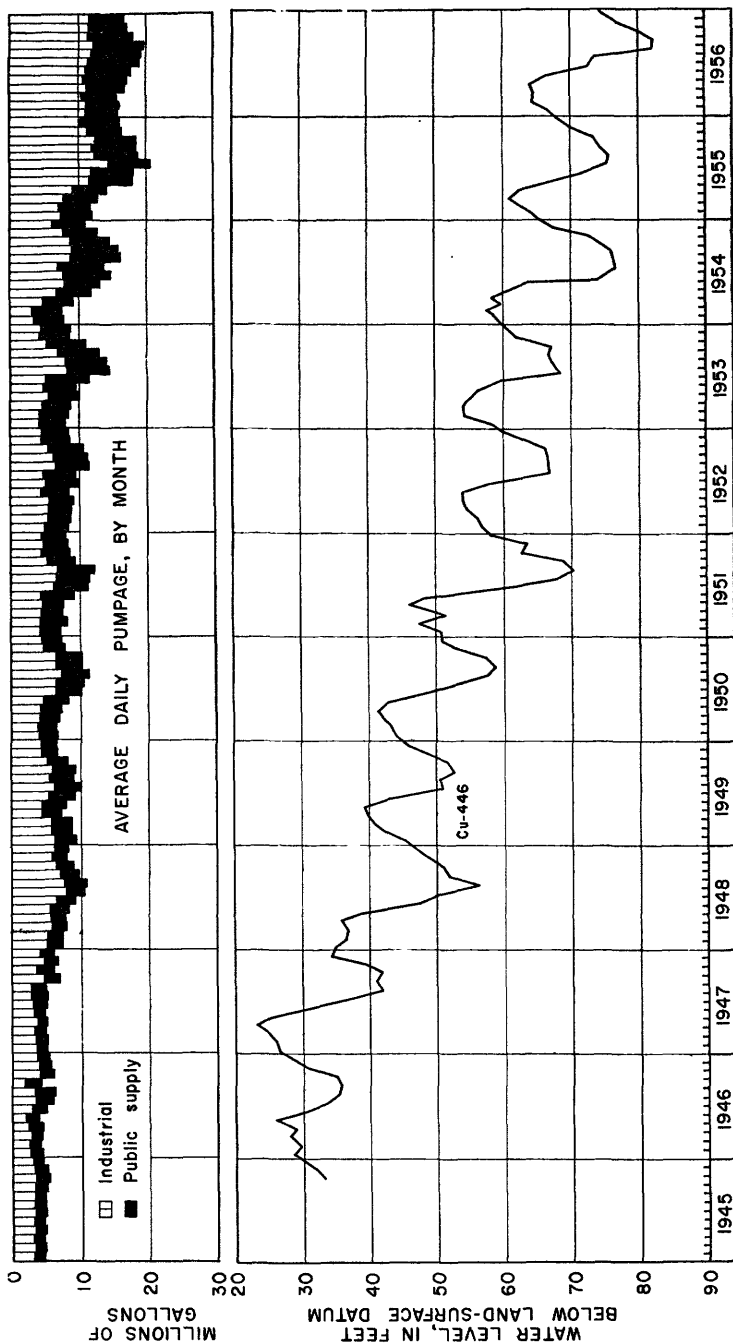

FIGURE 26.—Graph showing the relation of water levels in a well to pumpage from the "700-foot" sand in the industrial district.

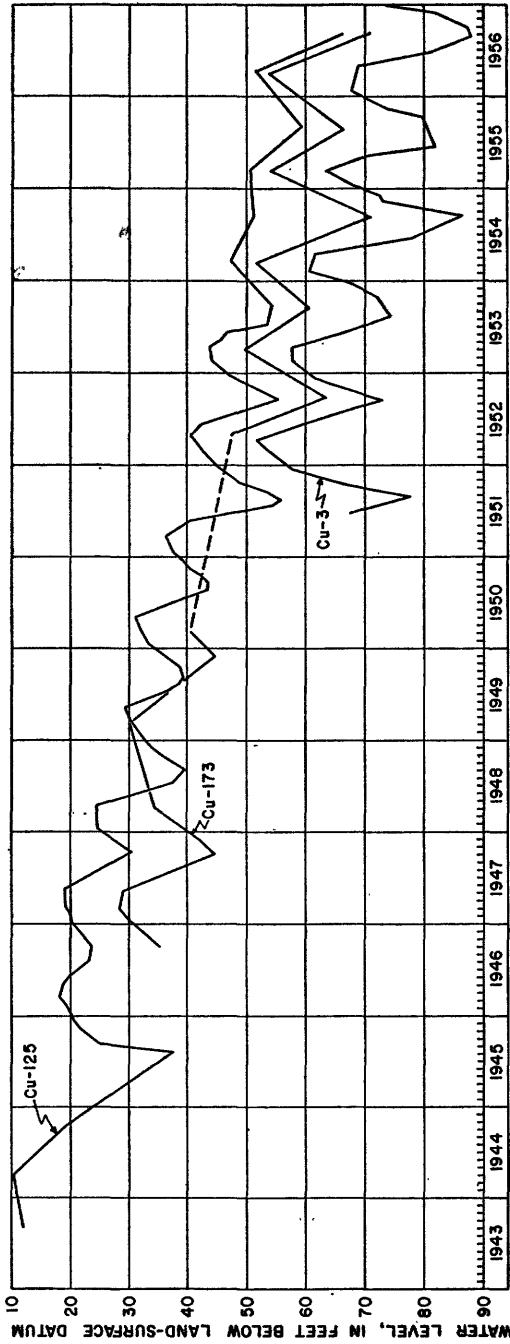

FIGURE 27.—Hydrographs of wells screened in the "700-foot" sand outside the Industrial district.

**DEPTH OF OCCURRENCE OF FRESH GROUND WATER**

A map (plate 9) of Calcasieu Parish showing the maximum depth of occurrence of fresh ground water was prepared from data obtained from electrical logs of oil-test wells. The contour lines on the map connect points of equal altitude below mean sea level at the base of the fresh-water-bearing section. The base of this section is quite level throughout the southern and extreme eastern parts of the parish. Scattered over the entire area are mounds of salt water, which occur over some of the oil fields in the parish. At the Starks field, salt water occurs within 200-300 feet of the land surface, whereas within 2 miles around the field the depth to salt water is about 800 feet. Although the mode of occurrence of these mounds of salt water is not fully known, they may be due to upward movement of salt water along fault planes cutting fresh-water-bearing zones, displacement of salt-water-bearing beds upward so they are in contact with those containing fresh water, contamination of fresh-water-bearing sands during drilling of oil or other deep wells, or contamination of fresh-water-bearing sands by movement of salt water through defective well casings.

There is a rather abrupt increase in thickness of the fresh-water-bearing section north of the Houston River. The base of the fresh water is at a depth of 800 feet near Sulphur, 1,000 feet at the Houston River north of Sulphur, and 2,500 feet north of DeQuincy. This change in thickness of the fresh-water body probably marks the southern extent of flushing of the deeper sands by fresh ground water. Electrical logs of oil-test holes drilled in this area show fresh-water-bearing sands underlying those containing salt water. This interfingering of sands containing fresh and salt water is not fully understood but may be due to differences of head in, and permeability of, the sand beds; for example, other things being equal, the salt water would be flushed more rapidly from sands having a relatively high permeability than from those having a low permeability.

**SALT-WATER ENCROACHMENT**

The chloride content of water is increasing in the "200-foot" sand in the vicinity of Iowa, in the "500-foot" sand in the vicinity of the Starks oil field, and in the "700-foot" sand in the industrial district. The source of this salt water is not the overlying streams, lakes, or gulf but is within the sands themselves or the underlying or overlying sands containing salt water. Salt-water encroachment can occur by the lateral movement of saline water through a formation, vertical movement through confining materials, movement in the vicinity of salt domes and associated structural features, and leakage through defective wells.

LATERAL MOVEMENT

The sand and gravel of the aquifers in Calcasieu Parish probably were deposited in an estuarine or near-shore environment, where saline water was trapped in the aquifers. Rain falling on the exposed surfaces of the sands and gravels served to flush out the salt water. The southern extent of this flushing is dependent upon the time available since deposition of the sand and upon the rate of movement of water in the aquifer. Because the aquifers of Calcasieu Parish pinch out toward the south, the rate of movement of the water under natural conditions was probably governed by vertical seepage from the sands through overlying confining beds.

Originally the direction of movement of the water in the principal sands in Calcasieu Parish was southward and served to push the fresh water-salt water interface southward into southern Calcasieu and Cameron Parishes. Pumping has caused the hydraulic gradient to be reversed in the southern part of Calcasieu Parish, and ground water is moving northward toward areas of heavy withdrawals. Because of the lack of definitive observation wells, the exact location of the fresh water-salt water interface in the sands is not known. However, an approximation of the time required for the water to move from the southern edge of the parish toward the area of heavy pumping may be made by the method described in the report under "Analysis of piezometric maps." Under existing conditions the rate of movement is very slow, and many years would elapse before the salt-water interface could reach the industrial district.

The trend of chloride concentration in water from a large-capacity well (Cu-588) in the "500-foot" sand in the southern part of the industrial area is shown graphically in figure 28. For the past 4 years the chloride content of water from well Cu-588 and other wells in the southern part of the parish has been more or less constant, indicating that the salt water within the "500-foot" sand has not moved northward into the industrial district.

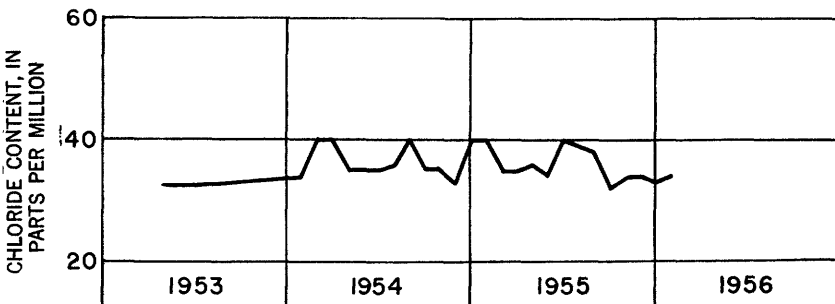

FIGURE 28.—Graph showing the chloride content of water from well Cu-588.

The chloride content of water from wells screened in the "700-foot" sand is given in table 7. Within the industrial district, the chloride content of water pumped from the "700-foot" sand has increased more rapidly than in other known areas of increasing chloride. This increase of chloride in the industrial district is shown graphically on figure 20. In well Cu-96 (736 feet deep) the chloride content increased from 285 ppm in 1945 to 450 ppm in 1951. In well Cu-98 (767 feet deep) the chloride content increased from 95 ppm in 1945 to 340 ppm in 1952. Records of the quality of water from well Cu-462 (724 feet deep) show that the chloride content increased from 20 ppm in 1949 to 215 ppm in 1955. Well Cu-96, drilled in 1943, was put on a standby basis in 1947 because of the high concentration of chloride in the water. During 1947-51 well Cu-96 was pumped only for the purpose of determining the chloride content of the water. Well Cu-98 was put into production late in 1942, was retired to standby basis in 1950 and was pumped only to obtain water for determinations of the chloride content during 1951-52. The progressive contamination of the "700-foot" sand, as shown on figure 20, indicates that local contamination is by residual salt water in the lower part of the sand or by the advance of a nearby salt-water interface as the result of pumping.

#### VERTICAL MOVEMENT

In an area such as Calcasieu Parish, where fresh-water-bearing sands overlie and may be separated from salt-water-bearing sands by a relatively thin clay layer, movement of salt water through clay into fresh-water-bearing sands can occur if the hydrostatic head in the fresh-water-bearing sand is less than that in the salt-water-bearing sand. A theoretical example of this type of contamination can be considered under the following assumptions: The clay underlying a fresh-water aquifer is 50 feet thick; the difference in head of the water contained in the two aquifers is 10 feet; and the permeability of the clay is 0.2 gpd per square foot (Wenzel, 1942, p. 13). Then from formula (2)

$$Q = PIA$$

$$= \frac{0.2 \times 10 \times 1 \times (5,280)^2}{50} = 1,100,000 \text{ gallons per day per square mile.}$$

Although no permeability measurements of clay have been made in Calcasieu Parish, the above example clearly shows that, considering the areas involved, significant amounts of water can move through a relatively thick clay bed. As indicated by the increasing chloride content of the water, there may be contamination of the "700-foot" sand by underlying salt-water-bearing sands in the vicinity of the Lockport and Sulphur Mines oil fields.



Another way in which salt water can enter fresh-water aquifers is by downward movement of saline water from shallow sands into the deeper fresh-water-bearing sands. In Calcasieu Parish, water from well Cu-562, which is 22 feet deep, has a chloride content of 1,320 ppm (table 7). Because of the higher water level in the shallow sand, this saline water could migrate to deeper fresh-water-bearing sands. Sufficient data to indicate conclusively whether this type of contamination is occurring in Calcasieu Parish are lacking.

#### MOVEMENT IN VICINITY OF STRUCTURES

The contamination of fresh-water-bearing sands by movement of salt water upward through the disturbed sedimentary rocks overlying salt domes has been suggested as an explanation of the salt-water mounds (pl. 9) overlying many oil fields in Calcasieu Parish. However, Winslow and Doyle (1954, p. 30) suggest that "some of the apparent contamination may be the result of a lack of circulation rather than actual contamination from the salt or underlying salt-water sands." At the Starks dome, water from wells Cu-613 (85 feet deep) and Cu-585 (483 feet deep) had concentrations of chloride of 430 ppm and 907 ppm, respectively. No hydrologic boundaries that might indicate the presence of faulting in this area were determined during the pumping test made on these and other wells. For this reason, contamination of the shallow sands by the movement of saline water along fault planes is not considered to have been effective in this area.

#### DEFECTIVE WELLS

Fresh-water-bearing sands can be contaminated by the movement of salt water through defective wells. Wells having leaky casings may serve as effective conduits for the passage of salt water into sands containing fresh water. This means of contamination has been described in reports on other areas (Thompson, 1928, p. 98-107; Sayre, 1937, p. 77; Bennett and Meyer, 1952, p. 158-173; Piper and others, 1953). Although such contamination has not been proved in Calcasieu Parish, it may occur to some degree in abandoned oil and sulfur wells.

#### CORRECTIVE MEASURES

It will be necessary to continue the collection of data on the location of salt water in Calcasieu Parish to determine the sources of local contamination. After the sources are determined it may be possible to inaugurate corrective measures to prevent the spread of contamination. Such measures may include protective pumping, the repair of leaky casings, control of discharge of water from wells, or other methods designed to meet specific problems.

## WELL CONSTRUCTION AND METHODS OF LIFT

## EXPLORATORY METHODS

Generally when a well or well field is to be installed, test holes should be drilled to determine the occurrence of the fresh-water-bearing sands. During drilling, an accurate record should be made of the beds penetrated, the drilling time required, and formation samples collected. After the test hole has been drilled to the specified depth, it is desirable to make an electrical log for correlation purposes and to determine the occurrence of sands containing fresh water. If the data collected from the test hole indicate favorable conditions, the hole is reamed to the desired diameter, and the supply well installed.

The electrical log is a record of the potential and resistivity of the formations penetrated by the well bore. The spontaneous-potential curve (in millivolts) is generally shown as a single trace on the left side of the conventional commercial electrical log, and the resistivity curves, on the right side. In the gulf coast area, of which Calcasieu Parish is a part, the spontaneous-potential curve generally has a positive deflection opposite fresh-water-bearing sands and a relatively large negative deflection opposite salt-water-bearing sands. In Calcasieu Parish the resistivity reading (measured in  $\frac{\text{ohm m}^2}{\text{m}}$ ) generally is high opposite sands containing fresh water and low (less than  $20 \frac{\text{ohm m}^2}{\text{m}}$ ) opposite salt-water-bearing sands and shales. This selection of 20 ohms for determining fresh-water-bearing sands from electrical logs is based upon a correlation of resistivity readings from logs and quality-of-water data in southwestern Louisiana.

A drill-stem test may be made if it is necessary to determine precisely the quality of water. A short length of screen is attached to the drill stem and is set opposite the sand to be tested. To prevent contamination of the water, packers are usually set above and, if needed, below the section being tested. After an adequate water sample is collected, the drill stem and screen are removed from the hole. Drill-stem testing may be used also to obtain water-level measurements and data on the potential yield of a supply well.

## CONSTRUCTION

All the industrial, municipal, and irrigation wells, and most of the rural supply wells in Calcasieu Parish have been drilled by the hydraulic-rotary method. The drilling is done by rotating a bit on the end of a drill-stem pipe which is screwed onto the kelly, a section of drill pipe, either square or ribbed that fits into the drive

bushing in the rotary table on the derrick floor. A mud fluid, sufficiently viscous to seal up the walls of the hole and to carry the cuttings to the surface, is pumped, under pressure, down the drill pipe and out through holes in the bit. Jetted against the bottom of the well with high velocity, the fluid is deflected upward to the surface between the drill pipe and walls of the hole carrying the drill cuttings.

Another recently developed method used in some areas of Louisiana for drilling water wells is the reverse-rotary method. In this method clear water flows from a pit on the surface down the annular space between the drill pipe and walls of the hole. The cuttings and water are returned in an ascending stream through the drill-stem pipe to the clear-water pit. A large pit and source of clear water are needed to replace water dissipated in permeable zones and to maintain a relatively constant head to prevent loss of circulation. After drilling is completed it is necessary that this head be maintained until the casing and screen are set. The principal advantage of the reverse-rotary method is that clear water is used for drilling and consequently the water-bearing material near the bore hole is not clogged with drilling mud. For this reason the well generally can be developed in a shorter period of time. However, most of the reverse-rotary rigs presently (1956) in use reportedly have not been used to drill below a depth of about 600 feet. It has been reported that newer techniques and developments will allow reverse-rotary drilling to greater depths.

The principal components of a typical industrial or irrigation well and its pumping equipment are shown in figure 29. The purpose of the pit casing is to provide ample space for installation and submersion of the pump. Where water levels are declining, as they are in Calcasieu Parish, care should be taken to set a sufficient length of pit casing so that the pump bowls will be deep enough to prevent loss of suction. When the pumping level declines below the pump bowls, the quantity of water delivered decreases rapidly until the pump breaks suction. If the pump bowls are set at the bottom of the pit casing and the water levels decline below the limit of suction lift, it is necessary either to install a smaller pump with less capacity in the well casing below the bottom of the pit casing or to construct a new well.

In Calcasieu Parish there are two general types of wells: a gravel-pack well made by reaming the hole to a large diameter (as much as 28 to 32 inches) in the sand to be screened, and placing sized gravel around the screen; and the so-called natural-pack well in which the screen is set opposite the sand without introduction of gravel. In natural-pack wells the size of the openings in the screen is such that the finer grained 40 to 70 percent of the sand grains,

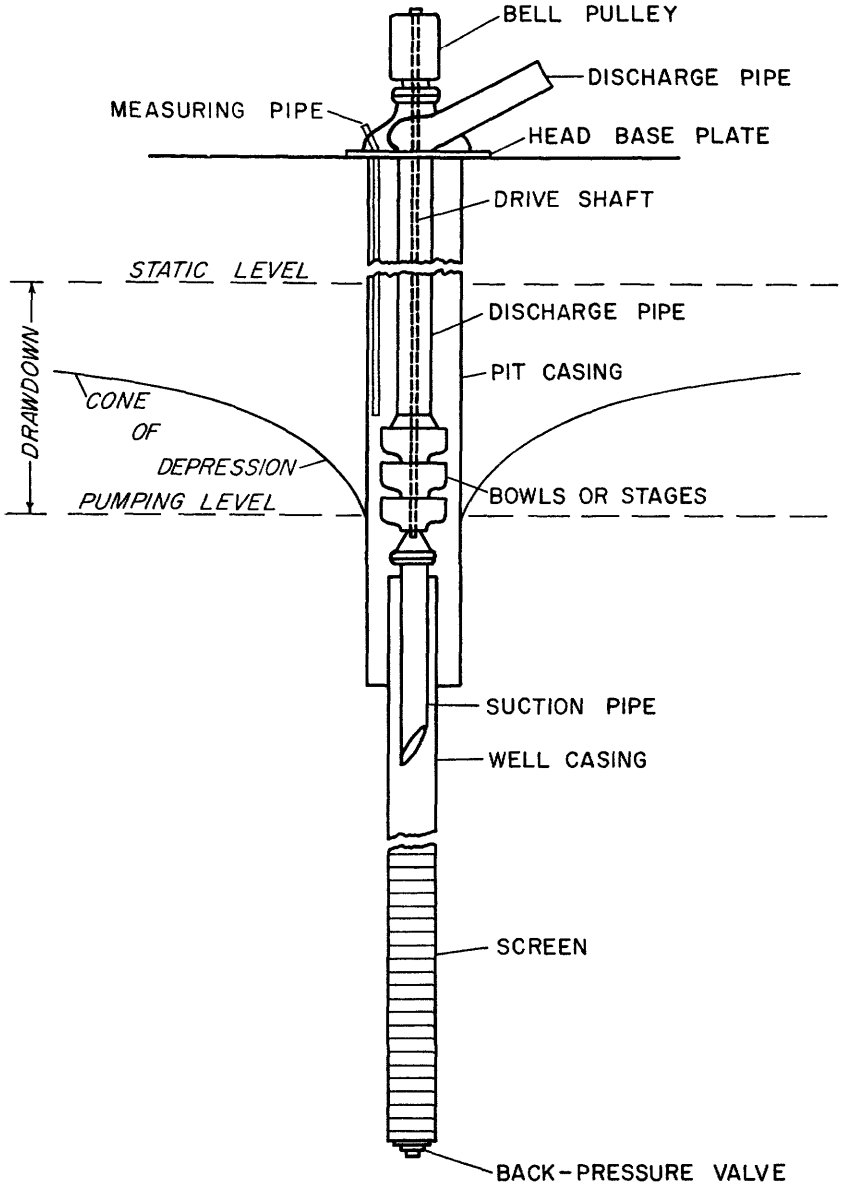

FIGURE 29.—Typical irrigation well.

as shown by the mechanical analysis, will pass through the screen and into the well. In irrigation wells the finer grained 90 percent of the sand grains is allowed to pass through the screen.

The well is developed by backwashing, surging, crosswashing, or overpumping, or by a combination of these processes. For maximum

well efficiency, development should continue until the specific capacity no longer increases with increased yield. Development generally is continued until a yield is obtained that is greater than that of the permanent pump but less than the critical discharge. (See fig. 7.) This is based on the theory that the velocity of water toward the screen during normal operation will be less than that incurred during the development of the well and thus there will be no transportation of fine sand toward and through the screen of the completed well.

#### METHODS OF LIFT

The size and type of pump used depend principally upon the pumping lift (distance from land surface to water level in the well being pumped), the quantity of water desired, the external head, and the diameter of the pit casing. In turn, the type and power of the engine used to operate the pump are determined by the capacity and speed of rotation of the pump and by the total lift. Rural supply wells in the shallow sands are usually equipped with pitcher pumps, and rural wells in the principal sands of the Chicot aquifer are equipped with small-capacity deep-well turbine or jet pumps. All public-supply, industrial, and rice-irrigation wells have deep-well turbine pumps of capacities dependent upon the needs of the user. With few exceptions, rural, public-supply, and industrial wells in Calcasieu Parish are powered by electricity. Of 76 inventoried rice-irrigation wells, 26 were equipped with diesel or semidiesel engines, 6 with natural-gas engines, 4 with electric motors, and 4 with butane-gas engines. The type of power used to operate 36 irrigation wells was not recorded.

#### SUMMARY AND CONCLUSIONS

The rocks of Calcasieu Parish that contain fresh water range in age from Recent to Miocene. No water wells have been drilled to the fresh-water-bearing sands of Pliocene and Miocene ages; however, records of wells in adjoining parishes indicate that moderate supplies of soft water are available from these beds. Small supplies, generally for domestic purposes, are available from shallow sands of Recent and Pleistocene ages. The principal aquifer (Chicot) in Calcasieu Parish consists of the "200-foot," "500-foot," and "700-foot" sands of Pleistocene age. In 1955 about 105 mgd of ground water was pumped in Calcasieu Parish. About 11 percent was from the "200-foot" sand, 66 percent from the "500-foot" sand, and 20 percent from the "700-foot" sand.

The principal users of this water are the many industries in the parish, rice irrigators, and the city of Lake Charles. Of the 105 mgd

used in 1955, 62 percent was for industrial use, 26 percent for irrigation, 8 percent for municipal supplies, and 4 percent for rural use.

The "200-foot" sand is generally thin in the western half of the parish; however, in the vicinity of Lake Charles and in the eastern half of the parish, it is quite thick and wells have an average yield of 2,800 gpm. Coefficients of transmissibility and storage are about 260,000 gpd per foot and 0.00086, respectively, in the southeastern part of the parish. The decline of water levels in the "200-foot" sand has been relatively small throughout the parish as a whole, averaging about 2 feet per year since 1946. The quality and temperature of the water make it a suitable source of supply for most purposes. This aquifer is a potential source of large additional amounts of water in the southeastern and central parts of the parish.

The "500-foot" sand is the most highly developed aquifer in the parish. This sand is a thick (as much as 310 feet), continuous unit throughout most of the parish, but it becomes thinner (25 feet) in the southeastern part of the parish. Yields from large-diameter wells screened in this sand range from about 1,300 to 4,000 gpm. Pumping tests made at various sites indicate the coefficient of permeability to range from 1,000 to 2,000 gpd per square foot. The water-level map (pl. 5) and the values of the coefficients of transmissibility and storage determined from pumping tests indicate that the water in the "500-foot" sand is moving southward at a greater rate than it moves northward into the industrial district. Static water levels have declined at a rate of about 5 feet per year at well Cu-445 in the industrial district. Although the present decline of water levels in the areas of heavy pumping is relatively large, as compared to the other sands, it is not excessive and must be expected in order to provide a gradient sufficient to move the required amount of water into the areas of pumping. A wider spacing of wells, as new ones are drilled to replace old wells, would minimize interference between them.

Except in small areas, there is no increase in the chloride content of the water in the "500-foot" sand as a result of the present withdrawals. The iron content of the water varies considerably, ranging from about 0.06 ppm to 11 ppm. However, areas of high iron content appear to be of only small extent. The temperature of water in the "500-foot" sand averages 74°F. On the basis of this study, it is concluded that the "500-foot" sand is capable of supplying additional amounts of water without any appreciable change in the quality of the water.

The "700-foot" sand is present throughout the parish and is capable of yielding large amounts of water. In some areas it contains small interbedded layers of clay, but the sands are considered

to be hydrologically connected. Within the industrial district this aquifer has an average thickness of 220 feet. Original yields of industrial wells screened in this sand average about 1,500 gpm. Because less water is pumped from this deeper sand, water levels have declined less and are generally higher than in the overlying "500-foot" sand. In the industrial district, at well Cu-446, the water level has declined from about 26 feet in April 1946 to 64 feet in April 1956, or about 3.8 feet per year. The water level in well Cu-3, a municipal-supply well, has declined at a rate of about 3.5 feet per year. The principal factor limiting development of this sand is the relatively high chloride content of the water in the central and southern parts of the parish. The temperature of the water ranges from 74° to 78°F.

Lowering of water levels and contamination by salt water are two of the principal problems in Calcasieu Parish. To prevent excessive lowering of ground-water levels, it is necessary that new wells be drilled as far from existing well fields as economically feasible. A wider spacing of wells will result in smaller declines of water levels in the well field and a concomitant saving of pumping costs. Salt-water contamination of the "700-foot" sand has caused the abandonment of several wells in some parts of the industrial district. Adequate data are not available to determine the mode of contamination accurately; however, widespread contamination does not appear imminent. As the source of contamination in each well or well field is determined, it may be possible to establish corrective measures to prevent the spread of salt water to nearby wells.

Because ground-water conditions in Calcasieu Parish are not static but change with time and development of ground water in the area, a program to collect and analyze current information should be continued. The principal phases of the program should include collection of well records, a continuing inventory of water use and measurement of water-level fluctuations, periodic sampling of water in selected wells to determine the status of salt-water encroachment, and detailed studies of the effect of geologic structural features on the occurrence and contamination of ground water.

## DESCRIPTION OF WELLS

The records of wells in table 6 are based on information obtained from many sources and are of different degrees of completeness and accuracy. The wells are located as accurately as possible, but many of the old wells in Calcasieu Parish are no longer visible and can be located only approximately. Wells for which records are incomplete or for which the location cannot be approximated within a reasonable distance are not included.

TABLE 6.—Description of

Type of well: B, bored;  
Use of water: A, abandoned; D, domestic; I, industrial; Ir,  
Remarks: L, driller's log in table 8; C, chemical

Well	Owner	Owner No.	Location			Date completed	Type of well	Depth of well (feet)	Casing	
			Sec.	T.S.	R.W.				Pit	
									Length (feet)	Diameter (inches)
Cu- 1	Town of Vinton		15	10	12	1939	Dr	585	536	8
2	do		15	10	12		Dr	422		
3	Greater Lake Charles Water Co.	H	31	9	8	1940	Dr	700		18
5	J. Turner		8	8	8		Dr	430		
6	Central La. Electric Co.		18	7	10	1940	Dr	654		
7	Calcasieu Parish School Board.		35	8	13	1929	Dr	601		
8	Krause and Managan		15	9	9	1895	Dr	500		
9	L. C. Managan		35	9	9	1938	Dr	178		
10	Krause and Managan		26	9	9	1940	Dr	193		
11	L. C. Managan		35	9	9	1942	Dr	475	85	4
12	Magnolia Petroleum Co.		4	10	9	1924	Dr	456		6
13	do		4	10	9	1925	Dr	716	52	12
14	do		4	10	9		Dr	796	85	16
15	do		9	10	9		Dr	500±		13
16	do		30	10	9	1938	Dr	328		
17	Cities Service Refining Corp.		24	10	10		Dr	500		
18	W. T. Burton		20	10	9	1933	Dr	330		
19	Bell Estate		10	10	10	1938	Dr	488		7
20	Magnolia Petroleum Co.		4	10	9		Dr	290		
21	Continental Oil Co.		8	10	9		Dr	265		
22	Magnolia Petroleum Co.		8	10	9	1935	Dr	560		13
23	Continental Oil Co.		8	10	9	1938	Dr	251		
25	Lake Charles Golf Club.		22	10	9	1920	Dr	500±		
27	Calcasieu Parish School Board.		26	9	9	1942	Dr	497		
28	Frank and Bob's Club		4	10	8		Dr	447		
29	Mr. Hinton		8	10	9	1942	Dr	442		
31	Greater Lake Charles Water Co.	K	31	9	8	1942	Dr	696		18
32	H. Hart		26	9	9	1942	Dr	198		4
33	Greater Lake Charles Water Co.	G	31	9	8	1925	Dr	500		12
34	do	A	31	9	8	1942	Dr	700		
35	do	F	31	9	8		Dr	500		
36	do	B	31	9	8		Dr	700		
37	do	C	31	9	8		Dr	700		
38	do	D	31	9	8		Dr	700		
40	Hardwood Lumber Co.		21	9	8	1942	Dr	400		6
41	do		21	9	8		Dr	400		6
42	Bell Estate		29	9	8	1925	Dr	504		
43	Halliburton Oil Well Cementing Co.		4	10	8	1937	Dr	500		
44	Calcasieu Parish School Board.		28	9	8	1940	Dr	430		
45	J. Verret		18	10	8		Dr	224		4
46	Missouri Pacific R.R.		9	10	8	1942	Dr	564		8
47	do		9	10	8	1910	Dr	575		7
48	{Calcasieu Parish School Board.		18	10	8		Dr	500		
49	{G. Boling		18	10	8	1939	Dr	195		
50	{McNeese State College.		19	10	8	1890	Dr	600±		
51	McCalls Dairy		20	10	8	1936	Dr	220		
53	Charles Sigler		34	9	9		Dr	200		
62	Charles Fay		22	10	9	1936	Dr	507		



## wells in Calcasieu Parish, La.

Dr, drilled; Du, dug.  
irrigation; N, none; O, observation; P, public; S, stock; T, test  
analysis for water collected in well in table 7

Casing		Screened interval (feet)	Aquifer	Static water level below or above (+) land-surface datum		Yield (gpm)	Use of water	Remarks
Well				Feet	Date			
Length (feet)	Diameter (inches)							
45	6	536-585	"500-ft"	0.5	June 1940		P	C.
	6		"500-ft"	.7	do			
			"700-ft"	12	1940	1,340	P	C.
			"500-ft"	87	September 1956			
580	6	580-654	"500-ft"	8	August 1940	360	P	L. Specific capacity 5 gpm per ft.
	12		"700-ft"	82	do			
	4		"700-ft"	1	do		P	C.
	8		"500-ft"				A	Flowed until 1936.
	2½		"200-ft"	7	1938		A	
	2½		"200-ft"	+13	November 1940		A	
	3½		"500-ft"	21	July 1942		P	
	4	414-456	"500-ft"	49	February 1950		I	
	6	675-716	"700-ft"	57	September 1956			
	8	668-765	"700-ft"	11	January 1943		A	
	4		"700-ft"	19	do		A	
	4		"500-ft"	8	do		A	
	4		"500-ft"	19	do		A	
	4		"500-ft"	17	do		A	
	4		"500-ft"	28	do		A	Flowed in 1933.
	4		"500-ft"	5	do		A	
	6		"500-ft"	55	1940		N	
			"500-ft"	46	August 1946			
	4		"200-ft"	26	January 1943		A	
			"200-ft"	47	March 1952			
	7	520-560	"500-ft"	8	April 1943		O	L. Flowed in 1935.
	6		"200-ft"	81	September 1956			
	4		"500-ft"	25	January 1943		A	Flowed until 1938.
			"500-ft"	9	do		A	
	4	490-497	"500-ft"	21	November 1942		P	
	2½		"500-ft"	9	January 1943		A	
	2½		"500-ft"	26	1942		D	
	10		"700-ft"	12	do	1,650	P	C.
	2½		"200-ft"	66	November 1942		D	
	6		"500-ft"	11	January 1943		P	L. Rescreened in 1935 in the "500-ft" sand only.
			"500-ft"	68	November 1955			
	8		"700-ft"	12	1942		A	
			"700-ft"	48	June 1951			
	6		"500-ft"				P	
	8		"700-ft"				A	
	8		"700-ft"				A	
	8		"700-ft"				A	
	4		"500-ft"	15	June 1942		I	
	3		"500-ft"	13	April 1943		A	Flowed when completed.
	6		"500-ft"	10	January 1943		A	
	3		"500-ft"	37	September 1947		A	
	3		"500-ft"	10	January 1943		A	
	4		"500-ft"	12	1940		P	
	2½		"200-ft"	27	January 1943		O	L.
			"200-ft"	53	March 1956			
	6	525-564	"500-ft"	13	April 1942		I	
	4		"500-ft"	14	January 1943		A	
			"500-ft"	25	October 1946			
	3		"500-ft"	22	January 1943		A	
	2½		"200-ft"	37	August 1949		A	
	4		"500-ft"	8	do		A	
	4		"500-ft"	10	October 1948		A	
	4		"200-ft"	20	January 1943		I	
	2½		"200-ft"				D	
	3		"500-ft"	20	1940		D	

TABLE 6.—Description of wells in

Well	Owner	Owner No.	Location			Date completed	Type of well	Depth of well (feet)	Casing	
			Sec.	T.S.	R.W.				Pit	
									Length (feet)	Diameter (inches)
Cu-65	G. Collins		22	9	8	1942	Dr	400		
71	Home Ideal Laundry		31	9	8	1940	Dr	463		
73	W. Williamson		4	9	8	1935	Dr	210		
74	Firestone Tire & Rubber Co.		18	10	9	1942	Dr	545	18	
75	do		18	10	9	1943	Dr	752	18	
76	do		18	10	9	1943	Dr	527	18	
77	{Olin Mathieson Chemical Corp.		35	9	9	1943	Dr	512	10	
78	do	1	34	9	9	1934	Dr	513	16	
79	do	2	34	9	9	1934	Dr	519	20	
80	do	4	35	9	9	1940	Dr	517	24	
81	do	3	35	9	9	1940	Dr	525	18	
82	do	5	34	9	9	1942	Dr	517	18	
83	do	6	35	9	9	1943	Dr	505	18	
84	{Lake Charles Harbor and Terminal District.		2	10	9	1926	Dr	677	16	
85	do		2	10	9	1937	Dr	503	12	
86	Continental Oil Co.	1	34	9	9	1940	Dr	529	18	
87	do	2	34	9	9	1940	Dr	236	24	
88	do	3	27	9	9	1940	Dr	275	24	
89	do	4	27	9	9	1940	Dr	520	18	
90	do	5	27	9	9	1940	Dr	255	24	
91	do	6	27	9	9	1940	Dr	526	18	
92	do	7	34	9	9	1942	Dr	701	18	
93	Cities Service Ref. Corp.	J-2	19	10	9	1943	Dr	521	402	
94	do	J-2B	19	10	9	1943	Dr	520	399	
95	do	J-2A	19	10	9	1942	Dr	527	399	
96	Petroleum Chemicals, Inc.	1	18	10	9	1943	Dr	736	612	
97	do	2	18	10	9	1943	Dr	519	18	
98	do	3	18	10	9	1942	Dr	767	18	
99	{Columbia-Southern Chemical Corp.	1	3	10	9	1942	Dr	667	18	
100	do	2	4	10	9	1942	Dr	685	18	
101	do	3	3	10	9	1942	Dr	670	18	
102	Union Oil and Gas Co.		29	9	10		Dr	575		
103	do		29	9	10		Dr	575		
104	do		29	9	10		Dr	575		
105	S. Hunter		21	9	11		Dr	480		
106	S. A. Emerson Oil Corp.		21	9	11		Dr	650		
108	Union Oil of California		33	10	12		Dr	668		
110	Central La. Electric Co., Inc.		18	7	10	1927	Dr	172		
111	do		18	7	10		Dr	300		
112	I. V. Maurer		25	9	9		Dr	210	4	
114	F. P. Friesen		29	11	8	1942	Dr	700	18	
115	Krause and Managan		11	9	10		Dr	348		

## Calcasieu Parish, La.—Continued

Casing		Screened interval (feet)	Aquifer	Static water level below or above (+) land-surface datum		Yield (gpm)	Use of water	Remarks
Well				Feet	Date			
Length (feet)	Diameter (inches)							
	2½		"500-ft"	{ 8	1942		D	
	4	451-463	"500-ft"	{ 13	April 1943		I	C.
190	2½	190-210	"200-ft"	20	July 1943		D	
	10	415-545	"500-ft"	11	November 1943	1,500	I	L. Specific capacity 42 gpm per ft.
	10	658-752	"700-ft"	10	March 1943	1,500	A	L. Specific capacity 15 gpm per ft.
	10	397-527	"500-ft"	7	January 1943	1,500	I	Specific capacity 47 gpm per ft.
	6	448-512	"500-ft"	{ 31	June 1943	1,500	O	
	10	433-513	"500-ft"	{ 121	August 1956		I	C. Specific capacity 31 gpm per ft.
	10	433-513	"500-ft"	99	October 1950	1,500	I	Flowed when completed.
	12	399-519	"500-ft"	46	October 1945	1,500	I	Specific capacity 75 gpm per ft.
	16	437-517	"500-ft"	{ +2	March 1940	1,500	I	Specific capacity 39 gpm per ft in 1950.
	10	435-525	"500-ft"	{ 90	October 1950		I	
	10	435-525	"500-ft"	{ 5	March 1940	1,500	I	Specific capacity 39 gpm per ft in 1950.
	10	435-525	"500-ft"	{ 108	October 1950		I	
	10	429-517	"500-ft"	{ 41	October 1945	1,500	A	C. Specific capacity 31 gpm per ft.
	10	442-505	"500-ft"	{ 69	September 1954		I	
	10	442-505	"500-ft"	30	July 1942	1,500	I	
	6		"700-ft"	{ 52	October 1949		A	C.
	6		"700-ft"	{ 62	June 1951		A	
	8	443-503	"500-ft"			1,350	I	
	10	429-529	"500-ft"	8	September 1940	2,000	I	C.
	12	156-236	"200-ft"	12	July 1940	2,000	A	
	12	195-275	"200-ft"	5	do	2,000	I	
	10	420-520	"500-ft"	5	August 1940	2,000	I	
	12	185-255	"200-ft"	8	September 1940	2,000	I	C. Specific capacity 50 gpm per ft.
	10		"500-ft"	7	July 1940	2,000	I	C.
	12	623-701	"700-ft"	21	July 1942	2,200	I	C.
68	10	408-521	"500-ft"	13	February 1943	2,000	I	
	10	413-520	"500-ft"	{ 12	January 1943	2,000	I	Specific capacity 32 gpm per ft.
	10	413-520	"500-ft"	{ 48	March 1943		I	
91	10	417-527	"500-ft"	{ 12	November 1942	2,000	I	L. Specific capacity 37 gpm per ft.
	10	417-527	"500-ft"	{ 42	June 1944		I	
63	10	641-736	"700-ft"	{ 12	October 1942	2,000	N	C. Specific capacity 26 gpm per ft.
	10	641-736	"700-ft"	{ 40	August 1945		I	
	10	410-519	"500-ft"	{ 12	October 1942	2,000	I	L. C. Specific capacity 30 gpm per ft in 1945.
	10	410-519	"500-ft"	{ 115	September 1956		I	
	10	629-767	"700-ft"	{ 12	December 1942	2,000	N	L. C. Specific capacity 17 gpm per ft.
	10	629-767	"700-ft"	{ 33	June 1945		N	
	12	562-646	"700-ft"	{ 12	May 1942	1,500	I	C. Test hole drilled to 852 ft. Specific capacity 71 gpm per ft.
	10	562-646	"700-ft"	{ 87	December 1951		I	
	10	589-685	"700-ft"	11	April 1942	1,500	I	
	10	572-670	"700-ft"	12	do	1,500	A	
	10		"500-ft"	7	August 1943		A	
	10		"500-ft"			100	I	
	10		"500-ft"			100	A	
	6		"500-ft"	6	November 1943		A	
	4		"700-ft"				A	
	6	648-668	"700-ft"				I	L, C.
	6	648-668	"200-ft"				A	
	2½		"500-ft"	51	August 1943		A	L.
	10		"200-ft"	41	April 1956	2,000	Ir	
	10		"500-ft"	41	April 1956	2,000	O	
	4		"500-ft"	{ 3	September 1943			
	4		"500-ft"	{ 21	September 1956			

TABLE 6.—Description of wells in

Well	Owner	Owner No.	Location			Date completed	Type of well	Depth of well (feet)	Casing	
			Sec.	T.S.	R.W.				Pit	
									Length (feet)	Diam-eter (inches)
Cu-117	Union Sulphur Co.		10	9	10		Dr	500±	24	
118	City of Sulphur		34	9	10	1929	Dr	510		
119	do.		34	9	10	1936	Dr	497	10	
120	Olin Mathieson Chemical Corp.		36	11	10	1933	Dr	700±		
122		Calcasieu Marine Bank.		22	11	10		Dr	723	
124	E. J. Stein		18	11	10		Dr	700±	24	
125	C. Patterson		34	10	10		Dr	700	24	
126	Swift Packing Co.		1	10	8	1937	Dr	510	12	
127	do.		1	10	8	1942	Dr	517	12	
128	S. Alford		25	9	8	1939	Dr	418	4	
130	H. Huber		31	9	6		Dr	360		
133	Shell Oil Co.		13	9	7	1932	Dr	291	9	
134	do.		13	9	7	1933	Dr	261	9	
135	do.		6	11	9	1933	Dr	526		
136	do.		23	9	7	1933	Dr	243		
137	do.		30	9	6	1933	Dr	306	7	
138	Magnolia Petroleum Co.		12	9	7		Dr	297	9	
144	M. Chatagnier		32	9	6	1943	Dr	312		
145	B. Pelican		32	9	6		Dr	343		
146	B. Pugh		17	10	6		Dr	350	24	
147	J. Metzger		18	10	6	1920	Dr	359	24	
148	do.		18	10	6	1942	Dr	366	20	
150	E. Daughenbaugh		31	10	7	1918	Dr	667	24	
151	do.		29	10	7	1943	Dr	860	90	
153	do.		7	11	5		Dr	400±		
156	O. Primo		35	10	7	1917	Dr	454	24	
157	U.S. Air Force		9	11	7		Dr	232		
158	R. Gregg		30	11	6		Dr	440	24	
159	E. Fruge		25	11	7	1938	Dr	424	24	
160	J. Demarest		35	11	7		Dr	387	24	
161	Calcasieu Marine Bank.		26	11	7		Dr	450	24	
162	Stanolind Oil and Gas Co.		4	11	7	1917	Dr	700	24	
163	do.		5	11	7	1917	Dr	700	24	
164	S. Vallet		13	11	8	1943	Dr	359	18	
165	W. Helm		29	11	7	1943	Dr	386	18	
166	F. Helm		17	11	7		Dr	388	24	
167	L. Wittler		35	11	8	1943	Dr	350	18	
168	A. Gayle		26	11	8		Dr	375	24	
169	do.		1	11	8		Dr	376	18	
171	do.		1	11	8		Dr	375	24	
172	E. Cobena		2	11	8	1943	Dr	630	18	
173	Charles Linkswiler		26	10	8	1926	Dr	726	24	
177	R. Peyton		27	10	8	1938	Dr	557	18	
179	I. Smith		21	10	8	1911	Dr	550	24	
181	C. Hoffpaur		28	10	8		Dr	805	24	
182	Calcasieu National Bank.		29	10	8		Dr	600	18	
186	V. M. Jones		35	9	8	1918	Dr	636	24	
203	F. Weber		29	8	8	1938	Dr	393		
204	Calcasieu Parish School Bd.		9	8	8	1931	Dr	428		
205	P. Bellon		22	8	8		Dr	354	18	
206	F. Gibson		26	8	8		Dr	340	18	
208	W. Caldwell		6	8	8	1942	Dr	455	90	
209	J. Tucker		14	9	9	1937	Dr	200		

DESCRIPTION OF WELLS

Calcasieu Parish, La.—Continued

Casing		Screened interval (feet)	Aquifer	Static water level below or above (+) land-surface datum		Yield (gpm)	Use of water	Remarks
Well				Feet	Date			
Length (feet)	Diameter (inches)							
	12		"500-ft"	{ 11	August 1943		A	
	10		"500-ft"	{ 23	January 1955		P	
	6		"500-ft"	{ 1	February 1936	325	O	C.
	4		"500-ft"	{ 4	August 1943		O	C. Flowed in
	10		"500-ft"	{ 46	September 1956		Ir	1942.
	12		"500-ft"				A	
	12		"700-ft"	{ 8	August 1943		D	
	8	490-510	"500-ft"	{ 66	September 1956		I	
	8	437-517	"500-ft"	{ 9	June 1937		I	L.
	2 1/4		"500-ft"				D	C.
	4		"200-ft"	17	September 1943		D	C.
	4		"200-ft"	32	April 1952		D	
	6	251-291	"200-ft"	24	September 1943	100	I	Specific capacity 20 gpm per ft.
	7	228-261	"200-ft"				I	
	6	496-526	"500-ft"				I	L.
	6	222-243	"200-ft"				I	L.
	6	284-306	"200-ft"				P	L.
	6		"200-ft"				I	
	10	228-312	"200-ft"			2,500	Ir	C.
	12	268-348	"200-ft"				Ir	
	12		"200-ft"	43	April 1956		Ir	C.
	10		"200-ft"	9	September 1943		A	L.
	10	274-366	"200-ft"	36	January 1950		Ir	
	12		"500-ft"	20	September 1943		Ir	
661	10	760-860	"700-ft"	{ 29	do		Ir	C.
	4		"200-ft"	{ 55	April 1956		P	
	10		"200-ft"	23	1943		Ir	L.
	6		"200-ft"				A	C.
	12		"200-ft"	41	September 1956		Ir	
	10		"200-ft"	14	September 1943	2,850	Ir	L.
	12		"200-ft"				Ir	
	12		"200-ft"	{ 10	April 1944		O	C.
	10		"500-ft"	{ 36	September 1956		Ir	
	10		"500-ft"	16	September 1943		Ir	C.
	10	257-359	"200-ft"	{ 14	do	2,800	Ir	
				{ 59	September 1956		Ir	
	10	288-386	"200-ft"	{ 21	September 1943	3,000	Ir	L.
	10	298-388	"200-ft"	{ 60	September 1950		Ir	
	10	250-350	"200-ft"	{ 27	September 1943	2,700	Ir	
				{ 14	do		Ir	
	12		"200-ft"	{ 51	September 1956		Ir	
				{ 15	September 1943		Ir	
	10		"200-ft"	45	August 1955		Ir	
	12		"200-ft"	16	September 1943		Ir	
	10	543-680	"500-ft"	17	do		Ir	L, C.
	12		"700-ft"	{ 29	September 1943		Ir	L, C.
				{ 71	do		Ir	
	10		"500-ft"	{ 28	September 1956		Ir	
	12		"500-ft"	{ 50	September 1943		Ir	
	12		"700-ft"	{ 28	September 1956		Ir	
	10		"500-ft"	{ 27	September 1943		Ir	
				{ 27	do		Ir	
	10	498-636	"700-ft"	8	1942		A	L. Flowed until 1938.
			"200-ft"	9	1938		D	
	4		"500-ft"				P	
	8	293-354	"500-ft"	{ 20	October 1943		A	C.
				{ 30	December 1949		Ir	
	10	280-340	"500-ft"	19	October 1943	1,500	Ir	
294	10	375-455	"500-ft"	{ 21	do	2,800	Ir	L, C.
	3		"200-ft"	{ 49	September 1956		A	C.
				{ 46	January 1947			

TABLE 6.—Description of wells in

Well	Owner	Owner No.	Location			Date completed	Type of well	Depth of well (feet)	Casing	
			Sec.	T.S.	R.W.				Pit	
									Length (feet)	Diameter (inches)
Cu-211	Shell Pipe Line Corp.	8	35	8	10	1942	Dr	335		
213	Newport Industries	8	18	7	10	1932	Dr	658		12
214	do	9	18	7	10	1934	Dr	346		12
215	do	10	18	7	10	1937	Dr	365		12
216	do	11	18	7	10	1937	Dr	608		16
217	do	12	18	7	10	1939	Dr	610		18
218	do	1	18	7	10		Dr	679		
219	Humble Oil Co.		32	7	10		Dr	300		
225	Shell Pipe Line Co.		20	10	12	1942	Dr	338		
226	Ed. Broussard		6	11	12	1928	Dr	500		
227	E. Garrie		29	9	12	1941	Dr	426		
228	R. Royer		14	9	12	1934	Dr	425		
230	E. Wilson		22	9	12		Dr	700±		18
233	E. Wright		1	10	12		Dr	535	100	18
238	Charles Millet Est.		29	9	11		Dr	500		
241	T. Stegall		34	9	11	1944	Dr	420	100	18
242	D. Hope		1	10	11		Dr	355		
243	E. Hoffpaur		26	9	10		Dr	500±		24
245	W. Keever		34	8	10		Dr	300±		24
252	W. Pickett		5	11	11		Dr	397		
255	W. Burton		20	11	11		Dr	515		
256	M. Grey		1	11	12		Dr	516		
261	W. S. Green		5	11	10		Dr	600		
263	M. Drost		3	11	10		Dr	560	100	18
264	do		3	11	10		Dr	525		
270	A. Ihle		23	10	9	1940	Dr	212		4
289	D. Carathers		24	10	9		Dr	455		
291	C. Heard		14	10	9	1939	Dr	480		
295	H. Guth		25	10	9	1917	Dr	308		
345	J. Abrahams		17	10	8	1930	Dr	460		
347	J. Waite		26	9	7	1909	Dr	280		24
349	J. Stevens		3	10	8	1937	Dr	575		4
357	S. Guldry		27	9	8	1940	Dr	468		
360	T. Gormley		27	9	8		Dr	700		
364	S. Vincent		10	11	10	1943	Dr	575		24
373	H. Hoffpaur		10	10	10	1936	Dr	385		
389	B. Carr		13	9	9	1940	Dr	171		
409	J. Sutherland		35	9	9	1943	Dr	198		
411	Bob Lee Lumber Co.		26	9	9	1942	Dr	426		
420	G. Anderson		35	9	9		Dr	200		
423	Kelly-Weber Co.		36	9	9	1940	Dr	210		
424	J. Micelle Packing Co.		12	10	9		Dr	500±		
425	Southern Pacific R.R.		32	9	8		Dr	385		
429	U.S. Air Force		2	10	8	1941	Dr	682	200	10
430	do		2	10	8	1941	Dr	684		10
431	J. Harrop		2	10	8	1918	Dr	640±		24
438	E. Hebert		11	9	10		B	20		
440	U.S. Air Force		2	10	8		Dr	500±		
442	do		2	10	8	1941	Dr	682	201	10
443	do		2	10	8	1941	Dr	684	206	10
444	do		2	10	8	1942	Dr	553		12
445	Cities Service Ref. Corp.		18	10	9	1945	Dr	540		18
446	do		18	10	9	1945	Dr	738		18
447	Town of Maplewood		31	9	9	1943	Dr	493	195	10
448	do		32	9	9	1943	Dr	496	200	10
449	Olin Mathieson Chemical Corp.	7	34	9	9	1945	Dr	517	262	18

Calcasieu Parish, La.—Continued

Casing		Screened interval (feet)	Aquifer	Static water level below or above (+) land-surface datum		Yield (gpm)	Use of water	Remarks
Well	Length (feet)			Diameter (inches)	Feet			
		7	574-658		"500-ft"	5	November 1942..	
	8	283-346	"700-ft"				A	
	8	305-365	"500-ft"	40	October 1943..		N	
	10		"700-ft"				I	C.
	10	530-610	"700-ft"			1,350	I	L.
			"700-ft"				N	
	4		"500-ft"	{ 27	April 1944..		I	C.
				{ 51	September 1956..		I	
	7	308-338	"500-ft"	{ 6	November 1942..		I	C.
	2½		"500-ft"	{ 24	April 1956..		A	C. Flowed until 1932.
			"500-ft"				D	
	405	405-425	"500-ft"	{ 8	October 1943..		D	
			"500-ft"	{ 11	do..		D	C.
	16		"700-ft"	{ 45	October 1956..		I	
	345	435-535	"500-ft"	{ 11	November 1943..		I	L.
			"500-ft"	{ 41	August 1955..		I	
	6		"500-ft"	{ 10	November 1943..		I	
	227	320-420	"500-ft"	{ 34	March 1955..	2,750	I	L.
			"500-ft"	{ 52	September 1956..		D	
	4		"500-ft"	{ 16	November 1943..		I	
	12		"500-ft"	{ 8	August 1945..		D	
			"500-ft"	{ 21	September 1956..		O	
	385	385-397	"500-ft"				D	C.
	4	475-515	"500-ft"				D	
	4		"500-ft"	{ 12	January 1950..		D	
			"500-ft"	{ 21	March 1954..		D	
	4		"500-ft"				D	Flowed until 1942.
	375	463-563	"500-ft"				I	L.
		515-525	"500-ft"				D	C.
	2		"200-ft"	42	October 1941..		D	C.
	2	445-455	"500-ft"				D	
	2		"500-ft"				D	
	4		"200-ft"				D	
	450	450-460	"500-ft"				D	
	12	210-280	"200-ft"	{ 30	October 1946..		A	C.
			"500-ft"	{ 36	March 1955..		D	
	2		"500-ft"				D	
	2		"500-ft"				D	
	4		"700-ft"				D	
	10		"500-ft"	40	April 1956..		I	
	4	373-385	"500-ft"				D	
	2		"200-ft"				D	
	2	188-198	"200-ft"				P	
	3	416-426	"500-ft"	22	July 1942..		I	
	2		"200-ft"				D	
	3		"500-ft"				I	
	6		"500-ft"				I	
	12		"500-ft"				A	
	415	615-682	"700-ft"	11	October 1942..	500	P	
	6	618-684	"700-ft"	14	May 1942..		A	
	12	540-640	"700-ft"	8	1942..	2,500	A	
	36		Recent				D	C.
	4		"500-ft"	{ 15	February 1944..		A	
				{ 47	September 1956..		A	
	612	662-682	"700-ft"	9	December 1941..	515	A	{C. Specific capacity 8 gpm per ft.
	423	664-684	"700-ft"	9	do..		P	L.
	8	500-553	"500-ft"	14	November 1942..		P	
			"500-ft"	{ 40	October 1945..		O	L.
	10		"500-ft"	{ 103	September 1956..		O	
			"500-ft"	{ 33	October 1945..		O	L.
			"500-ft"	{ 82	September 1956..		O	
	235	433-493	"500-ft"	26	June 1943..	680	P	{C. L. Specific capacity 14 gpm per ft.
	280	433-493	"500-ft"	{ 31	do..		P	{C. Specific capacity 24 gpm per ft.
			"500-ft"	{ 48	July 1948..	600	P	
			"500-ft"	{ 56	August 1945..		I	
	123	394-517	"500-ft"	{ 60	November 1947..	1,840	I	L.

TABLE 6.—Description of wells in

Well	Owner	Owner No.	Location			Date completed	Type of well	Depth of well (feet)	Casing	
			Sec.	T.S.	R.W.				Pit	
									Length (feet)	Diameter (inches)
Cu-450	Olin Mathieson Chemical Corp.		35	9	9	1945	Dr	523		18
451	Mr. Todd		3	11	7	1944	Dr	380		
452	R. Royer		23	8	12	1946	Dr	433		
453	C. Patterson		34	10	10	1947	Dr	345	101	20
454	Cities Service Ref. Corp.	J-20	19	10	9	1945	Dr	540	426	18
456	Paul Bellon		22	8	8	1948	Dr	436	141	20
457	Greater Lake Charles Water Co.	L	31	9	8	1946	Dr	696	575	16
458	Olin Mathieson Chemical Corp.	11	34	9	9	1948	Dr	509	359	18
459	do.	10	34	9	9	1948	Dr	511	250	18
461	Petroleum Chemicals, Inc.	4	18	10	9	1945	Dr	522	426	18
462	Cit-Con Oil Corp.	1	13	10	10	1948	Dr	724	620	18
463	do.	2	13	10	10	1948	Dr	533	400	18
464	do.	3	13	10	10	1948	Dr	532	406	18
465	Olin Mathieson Chemical Corp.	9	34	9	9	1947	Dr	520	232	18
466	Columbia Southern Chemical Corp.		20	9	10	1946	Dr	469		
467	do.		20	9	10	1946	Dr	472		
468	J. Stevens		3	10	8	1940	Dr	412		
469	do.		3	10	8	1944	Dr	495		
470	H. Landry		23	11	10	1948	Dr	287		
476	Union Sulphur Co.		21	11	10	19-2	Dr	650		
477	do.		17	11	10	1943	Dr	656		
478	do.		35	11	12	1943	Dr	603		
479	do.		35	11	12	1942	Dr	780		
483	U.S. Corps of Engineers.		21	11	9	1948	Dr	661	102	6
485	Pioneer Building		6	10	8	1948	Dr	518	420	10
486	Town of Westlake		26	9	9	1949	Dr	521	430	10
488	Vinton Petroleum Co.		33	10	12		Dr	600		
490	Krause and Managan		26	9	9		Dr	508		
492	Lakeside Laundry		31	9	8	1930	Dr	505		8
493	E. Daughenbaugh		29	10	7	1949	Dr	345		
494	J. Gayle		22	10	8	1949	Dr	577	160	20
495	Central La. Electric Co., Inc.		18	7	10	1948	Dr	660	584	12
496	do.		18	7	10	1949	Dr	746	587	12
497	F. Helms		17	11	7		Dr	412		
498	J. E. Daigle		28	11	8	1948	Dr	703		
501	Greater Lake Charles Water Co.	M	30	9	8	1949	Dr	690		16
502	City of Sulphur		34	9	10	1949	Dr	573	520	10
504	Magnolia Petroleum Co.		30	10	9	1949	Dr	500		
505	Kansas City Bridge Co.		36	9	9	1948	Dr	508		
506	A. Coleman		13	9	9	1948	B	35		
507	R. Sherwood		11	9	9	1941	Dr	154		
508	B. Lee		25	9	9	1945	Dr	371		
509	L. Johnson		3	10	10	1947	Dr	383		4
510	do.		9	9	10	1947	Dr	450		10
511	J. Stegall		34	9	11	1949	Dr	280		
512	T. Stegall		34	9	11	1946	Dr	363		
513	Ed. Stine		19	11	10	1945	Dr	533		4
514	Westlake Baptist Church.		35	9	9	1945	Dr	477		
515	M. Ellender		8	11	10	1948	Dr	570	120	18
516	Stein and Kinney		32	9	11	1941	Dr	401		4
517	H. Steward		12	8	9	1943	Dr	439	105	18



## Calcasieu Parish, La.—Continued

Casing		Screened interval (feet)	Aquifer	Static water level below or above (+) land-surface datum		Yield (gpm)	Use of water	Remarks
Well				Feet	Date			
Length (feet)	Diameter (inches)							
-----	10	393-523	"500-ft"	59	August 1945.....	1, 820	I	{ Specific capacity 32 gpm per ft.
-----	10	-----	"200-ft"	{ 30 42	{ January 1948 April 1956.....	{ 3, 100	Ir	
-----	8	348-433	"500-ft"	-----	-----	2, 000	I	L, C.
{ 20 159 93	{ 8 9 10	{ 270-345 430-540	{ "500-ft" "500-ft"	{ 28 41 40	{ January 1948 April 1956 August 1945.....	{ 3, 000 1, 500	{ Ir I	{ L, C.
-----	12	351-436	"500-ft"	{ 30 54	{ January 1948 September 1956.....	-----	Ir	L, C.
137	10	575-696	"700-ft"	30	August 1946.....	1, 500	P	-----
96	10	428-509	"500-ft"	80	1948.....	1, 340	I	Specific capacity 25 gpm per ft.
205	10	430-511	"500-ft"	{ 39 82	{ 1947..... 1950.....	{ 1, 280	{ I	{ Specific capacity 55 gpm per ft.
92	10	420-522	"500-ft"	40	1945.....	1, 500	I	-----
71	10	640-720	"700-ft"	-----	-----	1, 280	I	L, C.
51	10	409-533	"500-ft"	61	1948.....	1, 620	I	
49	10	310-405	"500-ft"	52	1948.....	-----	I	
200	10	437-520	"500-ft"	36	August 1947.....	1, 800	I	
-----	-----	-----	"500-ft"	-----	-----	-----	I	
-----	5	-----	"500-ft"	36	September 1948.....	-----	I	C.
-----	2	485-495	"500-ft"	-----	-----	-----	A	
-----	2	-----	"200-ft"	17	October 1948.....	-----	D	
-----	5	-----	"500-ft"	-----	-----	-----	I	
-----	5	-----	"500-ft"	-----	-----	-----	I	
-----	5	-----	"500-ft"	-----	-----	-----	I	
536	4	638-660	"500-ft"	30	October 1948.....	-----	P	
63	6	468-518	"500-ft"	-----	-----	-----	I	
101	6	451-521	"500-ft"	50	June 1949.....	670	P	
-----	6	-----	"700-ft"	-----	-----	-----	I	
-----	4	-----	"500-ft"	-----	-----	-----	A	
-----	12	265-345	"200-ft"	67	September 1956.....	-----	Ir	C. C. C. C.
384	12	497-577	"500-ft"	63	April 1956.....	4, 000	Ir	
393	6	595-655	"700-ft"	-----	-----	375	P	
404	6	686-746	"700-ft"	33	July 1949.....	460	P	C. L, C.
-----	-----	623-703	"200-ft"	63	September 1956.....	-----	Ir	
-----	10	-----	"500-ft"	52	do.....	-----	Ir	
-----	-----	-----	"700-ft"	55	July 1949.....	1, 760	P	
68	6	533-573	"500-ft"	37	August 1949.....	800	P	
-----	4	-----	"500-ft"	44	do.....	-----	D	
-----	4	488-508	"500-ft"	-----	-----	-----	I	D D D D D D D D D D
-----	2	142-154	"500-ft"	11	January 1950.....	-----	D	
-----	2	361-371	"200-ft"	36	October 1941.....	-----	D	
-----	3	371-383	"500-ft"	-----	-----	-----	I	
-----	3	371-383	"500-ft"	-----	-----	-----	D	
-----	8	370-450	"500-ft"	{ 28 53	{ January 1950 September 1956.....	{ 2, 500	{ Ir	
270	2	270-280	"200-ft"	-----	-----	-----	D	
383	2	383-393	"500-ft"	-----	-----	-----	D	
-----	2	573-593	"500-ft"	-----	-----	-----	D	
467	2	467-477	"500-ft"	-----	-----	-----	D	
399	10	490-570	"500-ft"	{ 22 50	{ January 1950 September 1956.....	-----	Ir	L, C.
-----	2	380-401	"500-ft"	-----	-----	-----	I	C.
265	10	357-439	"500-ft"	{ 35 45	{ January 1950 April 1956.....	{ 1, 400	Ir	C.

TABLE 6.—Description of wells in

Well	Owner	Owner No.	Location			Date completed	Type of well	Depth of well (feet)	Casing	
			Sec.	T.S.	R.W.				Pit	
									Length (feet)	Diameter (inches)
Cu-518	Todd Bros.		3	11	7	1947	Dr	255		3
519	F. Helms		17	11	7	1948	Dr	367		20
520	D. Lavoie		8	11	6	1948	Dr	414	129	18
521	Calcasieu Parish School Bd.		7	11	5	1945	Dr	375		
522	Charles Brown		7	11	5	1943	Dr	316		3
523	Gulf Oil Co.		18	11	5	1942	Dr	371		
524	Ed Taussig		15	10	9	1946	Dr	213		
525	Calcasieu Parish Police Jury		15	10	9	1941	Dr	198		
526	O'Meara Brothers		33	10	12	1945	Dr	652		
527	N. Stanfa		34	9	8	1947	Dr	468		4
528	E. Wilson		21	9	12	1944	Dr	511		20
529	M. Gray		5	11	12	1945	Dr	276		
530	do.		4	11	12	1948	Dr	595	120	20
531	do.		1	11	12	1948	Dr	514	120	20
532	do.		22	11	11	1948	Dr	568		20
533	Union Sulphur Co.		16	11	10	1945	Dr	655		
534	W. Corbello		6	10	12	1947	Dr	550	100	18
536	G. K. Rowlins		8	8	8	1949	Dr	477	140	14
537	Lake Charles Country Club.		22	10	9	1948	Dr	759	720	7
539	Mayo and McFadder		4	9	8	1944	Dr	200		
541	C. Reeves and Savol.		15	9	8	1945	Dr	480		
542	York Supply Co.		27	9	8	1946	Dr	484		4
543	J. Metzger		18	10	6	1946	Dr	212		
544	C. Cornett		28	10	6	1945	Dr	277		
545	J. Doucet		8	10	6	1947	Dr	244	97	4
546	Union Sulphur Co.		24	11	12	1943	Dr	535		
547	do.		35	11	12	1943	Dr	599		
548	Circle Drilling Co.		2	8	11	1949	Dr	250		
549	E. Dauchenbaugh		31	11	7		Dr	750		
550	C. Miller		15	8	8	1949	Dr	447	135	14
551	Alford Warehouse, Inc.		29	9	7	1950	Dr	460		
552	Olin Mathieson Chemical Corp.	5	34	9	9	1950	Dr	517		18
553	Greater Lake Charles Water Co.	N	31	9	8	1950	Dr	674	563	20
554	A. Bentley		30	7	10	1948	Dr	242	105	2
555	Town of Vinton		15	10	12	1950	Dr	602	502	12
556	Columbia-Southern Chemical Corp.	4	4	10	9	1950	Dr	697		16
557	General Box Co.	1	29	8	12	1947	Dr	480		
558	do.	2	29	8	12	1946	Dr	290		
559	do.	3	30	8	12	1946	Dr	290		
560	Cities Service Ref. Corp.	J-120	19	10	9	1951	Dr	574	421	20
561	Continental Oil Corp.	8	34	9	9	1951	Dr	287		
562	E. Ledoux		11	9	8	1950	Du	22		
564	Church of the Nazarene.		4	9	8		Du	25		
565	F. Walker		15	9	9	1948	Du	33		
566	R. Young, Jr.		17	9	9	1948	Du	17		
567	H. White		11	9	8	1933	Dr	700±		
568	Dripps and Rauser		6	9	12	1951	Dr	450		
569	A. Cornier		23	8	13	1951	Dr	453		20
570	J. Johnson		33	8	11	1951	Dr	400		26
572	Stein and Kinney		12	9	13	1950	Dr	515		
574	Gulf States Utilities Co.	1	3	10	9	1947	Dr	707		12
575	do.	2	3	10	9	1947	Dr	715		12
576	Olin Mathieson Chemical Corp.	13	34	9	9	1951	Dr	508	416	18

## Calcasieu Parish, La.—Continued

Casing		Screened interval (feet)	Aquifer	Static water level below or above (+) land-surface datum		Yield (gpm)	Use of water	Remarks
Well				Feet	Date			
Length (feet)	Diameter (inches)							
	4	240-255	"200-ft"				I	L.
	11	287-367	"200-ft"	36	January 1950		Ir	
200	14	334-414	"200-ft"	15	January 1950	2,000	A	
364	4	365-375	"200-ft"	39	September 1956		D	
	2	306-316	"200-ft"				D	
	2	361-371	"200-ft"				D	
	2	194-213	"200-ft"				D	
188	4	188-198	"200-ft"	15	February 1950		D	
	7	620-652	"500-ft"	9	January 1950		I	
		458-468	"500-ft"				D	
	12		"500-ft"	20	January 1950		A	
259	4	261-276	"500-ft"	35	September 1955		D	
403	10	515-595	"500-ft"	30	September 1956		Ir	
	11	422-514	"500-ft"	12	January 1950		Ir	
			"500-ft"	34	September 1956		Ir	
	12	{220-280}	"500-ft"	16	January 1950		Ir	
		{552-592}	"500-ft"	28	March 1955		Ir	
633	5	633-655	"500-ft"				I	
358	10	490-550	"500-ft"	27	March 1956	2,800	Ir	
122	8	417-477	"500-ft"	53	September 1956		Ir	
84	4	727-759	"700-ft"				I	
	2	190-200	"200-ft"				D	
190	4	460-480	"500-ft"				D	
460	2	474-484	"500-ft"				D	
			"200-ft"				D	
			"200-ft"				D	
265	2	265-275	"200-ft"				D	
145	3	234-244	"200-ft"				D	
514	4	513-534	"500-ft"				I	
578	4	577-598	"500-ft"				I	
	4		"200-ft"	28	March 1950		I	
			"500-ft"	34	April 1956		I	
			"500-ft"	21	April 1946		Ir	
			"500-ft"	55	September 1956		Ir	
22	10	363-447	"500-ft"	33	May 1950	2,500	Ir	
	2	450-460	"500-ft"	20	March 1950		I	
	10	429-517	"500-ft"	96	July 1950	1,500	I	
93	12	584-670	"700-ft"	60	September 1950	1,500	I	
126	1½	231-241	"200-ft"				D	
73	8	517-597	"500-ft"				P	
		597-697	"700-ft"			1,500	I	
	4		"500-ft"	20	July 1947		I	
	2		"500-ft"	30	July 1946		I	
	2		"500-ft"	30	do		P	
81	12	433-563	"500-ft"				I	
			"200-ft"				I	
	4	Recent		14	June 1951		D	
		Pleistocene		10	do		D	
	10	do		10	do		D	
	30	do		12	do		D	
	10	"700-ft"		18	do		D	
	10	"500-ft"		31	October 1951	3,000	Ir	
	10	"500-ft"		22	do		Ir	
			"500-ft"	38	do		Ir	
	12		"500-ft"	46	September 1956		Ir	
	12	435-515	"500-ft"	30	October 1951		Ir	
	8	626-707	"700-ft"	46	September 1956		Ir	
	8		"700-ft"	40	November 1946	800	I	
	8		"700-ft"	38	January 1947	800	I	
89	10	428-508	"500-ft"	88	October 1951	1,500	I	

Specific capacity 30 gpm per ft.

C. Water salty.  
C.

L.

L, C.

Specific capacity 12 gpm per ft.

Specific capacity 12 gpm per ft.

Specific capacity 54 gpm per ft.

TABLE 6.—Description of wells in

Well	Owner	Owner No.	Location			Date completed	Type of well	Depth of well (feet)	Casing	
			Sec.	T.S.	R.W.				Pit	
									Length (feet)	Diam-eter (inches)
Cu-577	Dripps and Rauser		8	9	12	1942	Dr	600		
578	F. Vail		17	11	8	1947	Dr	697		
579	Newport Industries	13	18	7	10	1947	Dr	652		18
580	Columbia-Southern Chemical Corp.	11	30	9	10	1946	Dr	469		12
581	do	12	30	9	10	1946	Dr	469		12
582	do	13	30	9	10	1951	Dr	609		18
583	do	3R	3	10	9	1951	Dr	670		18
584	U.S. Air Force	1	2	10	8	1952	Dr	577		
585	Jefferson Lake Sulphur Co.	1	19	9	12	1950	Dr	483	292	13
586	do	2	19	9	12	1950	Dr	495	401	16
587	Greater Lake Charles Water Co.	0	31	9	8	1952	Dr	674		
588	Davison Chemical Co.		25	10	10	1952	Dr	589	33	26
589	do		25	10	10	1952	Dr	585	33	
590	{Petroleum Chemicals, Inc.	5	18	10	9	1953	Dr	551	30	26
591	do		6	18	10	9	1953	Dr	545	418
592	J. Reeves		4	9	8	1943	B	18		
594	C. Shavers		33	8	8	1953	B	16		
595	C. Long		34	8	8	1943	B	14		
596	L. Koonce		25	8	8		B	22		
597	F. Goos		2	9	8	1900	B	27		
598	L. Bryant		23	8	8		B	20		
600	A. Nolan		10	8	8	1947	B	15		
601	R. Lee		2	8	8		B	42		
603			22	8	7		B	28		
604	Ryan		15	8	7		B	21		
606	D. Miller		27	8	7	1950	Du	28		
610	W. Freeman		36	9	9	1942	Dr	285		
612	Jefferson Lake Sulphur Co.	3	19	9	12	1952	Dr	76		13
613	do	4	19	9	12	1952	Dr	85		13
614	M. Drost		3	11	10	1954	Dr	548		20
616	G. Wooster		27	10	10		Dr	350		
617	Petroleum Chemicals, Inc.	7	18	10	9	1954	Dr	530	401	20
619	Cities Service Ref. Corp.	J-142	19	10	9	1953	Dr	613		22
620	do	J-143	19	10	9	1953	Dr	561	426	22
621	Stein and Kinney		31	11	11	1944	Dr	585		22
622	Continental Oil Co.	9	36	9	9	1951	Dr	219		12
624	Davison Chemical Co.		25	10	10	1948	Dr	500±		
625	Stein and Kinney		11	8	13	1952	Dr	460		
627	Gulf States Utilities Co.	1	3	10	9	1953	Dr	538		12
629	Ohio Petroleum Co.		20	11	13		Dr	778		
630	M. Rosfield		34	10	9	1945	Dr	625		
631	Magnolia Petroleum Co.		1	9	7		Dr	200		
632	Mr. Coffey		22	8	9	1954	Dr	202		20
633	G. Natly		18	11	7	1954	Dr	300±		
635	E. Fontenot		6	10	11	1955	Dr	460		22
637	J. Lamkin and K. Breaux		27	11	8	1955	Dr	585		16
639	Mrs. Managan		21	9	9	1960	Dr	487		12
640	J. Waite		26	9	7	1954	Dr	200		
641	Prairie Canal Co.		12	11	8	1951	Dr	365		18
642	F. Heyd		10	9	7	1949	Dr	287		14
643	Sweet Lake Land Co.		7	8	8	1954	Dr	424		12
644	Mr. Reeves		4	8	8	1946	Dr	426		18

DESCRIPTION OF WELLS

Calcasieu Parish, La.—Continued

Casing		Screened interval (feet)	Aquifer	Static water level below or above (+) land-surface datum		Yield (gpm)	Use of water	Remarks	
Well	Diameter (inches)			Feet	Date				
					Length (feet)				
	12		"500-ft"	26	December 1951..		Ir	C.	
	14		"500-ft"	29	March 1955.....		Ir		
	10	570-652	"700-ft"	20	August 1947.....	3,800	Ir	Specific capacity 18 gpm per ft.	
	8	389-469	"500-ft"	31	October 1946.....	1,000	I		
	8	389-469	"500-ft"	31	November 1946..	600	I		
	8	509-609	"700-ft"	44	December 1951..	1,000	I		
	10	550-650	"700-ft"	85	do.....	1,500	I	Specific capacity 24 gpm per ft.	
	8	500-577	"500-ft"	42	January 1954.....	630	P	C.	
	8	411-480	"500-ft"	43	September 1956..	1,000	A	C. Original yield 1,000 gpm.	
	343	401-454 466-484	"500-ft"						
									1,100
								P	
493	20	506-586	"500-ft"	46	1952.....	2,000	I	C. Specific capacity 41 gpm per ft.	
	104								20
490	20	433-551	"500-ft"	84	January 1953.....	2,000	I	C. Specific capacity 63 gpm per ft.	
108	10								427-547
417	20								
91	12								
85	12								
	5		Recent.....	6	April 1953.....			D	
	8		do.....	4	do.....			D	
	6		do.....	4	do.....			D	
	6		Pleistocene.....	12	do.....			D	
	8		Recent.....	22	do.....			D	
	8		Pleistocene.....	6	do.....			D	
	6		do.....	6	do.....			D	
	6		do.....	14	do.....			D	
	24		do.....	20	1953.....			D	
	24		do.....	18	1953.....			D	
	36		do.....	20	August 1953.....			D	
	4		"200-ft"	61	September 1956..			O	
50	8	50-72	Pleistocene.....	14	August 1952.....	250		C.	
	8	68-85	Recent.....	22	September 1952..	250	I	C.	
	10	468-548	"500-ft"	59	September 1956..	2,500	Ir	C.	
	3		"500-ft"	65	July 1954.....				
83	12	410-530	"500-ft"	79	May 1954.....	1,500	I	Specific capacity 55 gpm per ft.	
	12	490-610	"500-ft"	93	October 1953....	2,050	I	Specific capacity 50 gpm per ft.	
84	12	438-558	"500-ft"	96	August 1953.....	2,050	I	Specific capacity 33 gpm per ft.	
	10	505-585	"500-ft"	30	September 1956..		Ir	L.	
	7	185-217	"200-ft"	67	September 1951..	284	I	Specific capacity 24 gpm per ft.	
			"500-ft"	56	March 1955.....			D	
	12	310-460	"500-ft"	40	September 1956..	2,400	Ir	L, C.	
	8	488-568	"500-ft"						
	5		"500-ft"	21	September 1956..		I		
	10		"500-ft"	56	April 1956.....	2,500	Ir	C.	
	4		"200-ft"	38	do.....		I		
	12	142-204	"200-ft"	37	September 1956..	4,500	Ir	L, C.	
	10		"200-ft"	36	February 1955...		Ir		
	10		"500-ft"	46	September 1956..	3,800	Ir	C.	
	8		"500-ft"	41	April 1956.....		Ir	L, C.	
	8	410-470	"500-ft"	76	September 1956..		Ir	C.	
	12	140-200	"200-ft"	53	do.....		Ir	C.	
	10	265-365	"200-ft"	37	February 1955...		Ir	L.	
	8		"200-ft"	40	do.....				
	8		"200-ft"	22	1949.....	2,000	Ir	C.	
	8		"200-ft"	52	February 1955...	1,800	Ir		
	10		"200-ft"	53	do.....		Ir		

TABLE 6.—Description of wells in

Well	Owner	Owner No.	Location			Date completed	Type of well	Depth of well (feet)	Casing	
			Sec.	T.S.	R.W.				Pit	
									Length (feet)	Diam-eter (inches)
Cu-645	Sweet Lake Land Co.		29	8	8	1951	Dr	445		
646	J. Metzger		18	10	6	1955	Dr	330		20
647	Sweet Lake Land Co.		10	11	7	1918	Dr	400±		
649	Olin Mathieson Chemical Corp.	14	34	9	9	1952	Dr	522		20
651	D. W. Abbott		29	9	6	1953	Dr	400	121	16
652	do.		29	9	6	1953	Dr	400	121	16
653	Krause and Managan		11	9	10	1955	Dr	568		
654	Continental Oil Co.	10	27	9	9	1955	Dr	536		16
655	City of Sulphur		34	9	10	1955	Dr	585		
656	Love Estate		19	9	6	1910	Du	15		
660	Petroleum Chemicals, Inc.		18	10	9	1956	Dr	548	415	20
661	Greater Lake Charles Water Co.	8	6	10	8	1956	Dr	732	634	20
663	City of Westlake		26	9	9	1956	Dr	535	457	12
664	Cit-Con Oil Corp.	4	13	10	10	1956	Dr	501	389	18
665	Gulf States Utilitlies Corp.		9	9	9	1956	Dr	473	379	16
666	do.		9	9	9	1956	Dr	990	80	10
667	do.		9	9	9	1956	Dr	457		
668	Lake Charles Air Force Base.		14	10	8	1956	Dr	200	162	8
669	do.		14	10	8	1956	Dr	196	154	8
670	do.		12	10	8	1956	Dr	113	81	3
671	do.		11	10	8	1954	Dr	418		
672	do.		10	10	8	1954	Dr	86	73	3
675	do.	2	2	10	8	1946	Dr	511	436	
676	Cities Service Ref. Corp.	12	19	10	9	1957	Dr	553	420	22

## Calcasieu Parish, La.—Continued

Casing		Screened interval (feet)	Aquifer	Static water level below or above (+) land-surface datum		Yield (gpm)	Use of water	Remarks
Well				Feet	Date			
Length (feet)	Diameter (inches)							
-----	10	-----	"200-ft"-----	41	January 1955-----	-----	Ir	L.
-----	10	-----	"200-ft"-----	47	February 1955-----	-----	Ir	
-----	10	402-522	"200-ft"-----	28	do-----	-----	Ir	
-----	10	-----	"500-ft"-----	-----	-----	-----	I	-----
210	9	317-397	"200-ft"-----	-----	-----	-----	P	L, C.
210	9	317-397	"200-ft"-----	-----	-----	-----	P	-----
-----	10	435-535	"500-ft"-----	84	September 1955-----	2,000	I	L. Specific capacity 50 gpm per ft.
-----	10	485-585	"500-ft"-----	58	November 1955-----	-----	P	L.
-----	36	Pleistocene	"500-ft"-----	11	do-----	-----	D	C.
93	12	425-545	"500-ft"-----	105	August 1956-----	2,000	I	Specific capacity 44 gpm per ft.
100	12	649-729	"700-ft"-----	58	May 1956-----	1,800	P	C. Specific capacity 72 gpm per ft.
-----	8	485-535	"500-ft"-----	88	September 1956-----	500	P	Specific capacity 17 gpm per ft.
96	10	400-500	"500-ft"-----	93	do-----	2,000	I	Specific capacity 25 gpm per ft.
106	8	390-470	"500-ft"-----	62	June 1956-----	1,700	I	Specific capacity 36 gpm per ft.
{ 163	{ 8	930-990	Evangeline	49	July 1956-----	220	A	L. Salt-water supply; originally drilled to 2,204 feet. Specific capacity 2 gpm per ft.
755	6							
445	4	435-445	"500-ft"-----	-----	-----	-----	O	Ordinance area well 1.
35	6	175-198	"200-ft"-----	-----	-----	-----	P	
56	6	175-195	"200-ft"-----	-----	-----	-----	P	C. Ordinance area well 2.
21	2	101-111	Pleistocene	-----	-----	-----	S	C. Transmitter station.
407	4	407-417	"500-ft"-----	53	December 1956-----	-----	P	Radar control building.
5	2½	76-86	Pleistocene	-----	-----	50	S	Receiver station.
-----	-----	480-511	"500-ft"-----	-----	-----	450	P	C.
30	12	430-550	"500-ft"-----	120	August 1957-----	2,000	I	Specific capacity 70 gpm per ft.











TABLE 8.—*Drillers' logs of representative wells in Calcasieu Parish*

Material	Thickness (feet)	Depth (feet)	Material	Thickness (feet)	Depth (feet)
<b>Cu-6. Central Louisiana Electric Co., DeQuincy</b> [Sec. 18, T. 7 S., R. 10 W.]					
Soil.....	6	6	Gumbo.....	28	401
Clay.....	37	43	Shale, sandy, gumbo.....	168	569
Clay, sandy.....	22	65	Sand, fine, dirty.....	15	584
Gumbo.....	6	71	Sand.....	38	622
Shale, sandy.....	32	103	Gumbo.....	6	628
Sand.....	20	123	Sand.....	26	654
Gumbo.....	81	204	Gumbo.....	5	659
Sand, coarse, and gravel.....	169	373			
<b>Cu-22. Magnolia Petroleum Co., Lake Charles</b> [Sec. 8, T. 10 S., R. 9 W.]					
Clay.....	40	40	Sand and gravel.....	70	442
Sand and gravel.....	18	58	Shale.....	50	492
Sand.....	54	112	Sand and gravel.....	85	577
Gravel.....	190	302	Shale, sticky.....	75	652
Shale, sticky.....	70	372			
<b>Cu-33. Greater Lake Charles Water Works Co., Lake Charles</b> [Sec. 31, T. 9 S., R. 8 W.]					
Clay.....	18	18	Gumbo.....	84	315
Sand, white.....	51	69	Sand, fine, black.....	188	503
Clay.....	48	117	Sand, coarse.....	19	522
Sand, soft.....	17	134	Gumbo.....	12	534
Clay, sandy.....	97	231	Sand and gravel.....	152	686
<b>Cu-46. Missouri Pacific RR., Lake Charles</b> [Sec. 9, T. 10 S., R. 8 W.]					
Soil.....	4	4	Gravel.....	45	358
Clay.....	10	14	Gumbo.....	40	398
Sand, red.....	34	48	Sand, fine.....	46	444
Clay.....	153	201	Sand, coarse.....	75	519
Shale.....	45	246	Sand and gravel.....	45	564
Shale, sandy.....	67	313			
<b>Cu-74. Firestone Tire and Rubber Co., Lake Charles</b> [Sec. 18, T. 10 S., R. 9 W.]					
Soil.....	12	12	Gumbo.....	86	386
Sand, red.....	28	40	Sand.....	169	555
Clay.....	12	52	Shale.....	60	615
Shale.....	110	162	Gumbo.....	10	625
Shale, sandy.....	22	184	Sand.....	105	730
Sand.....	96	280	Gumbo.....	10	740
Sand and shale.....	20	300			

TABLE 8.—*Drillers' logs of representative wells in Calcasieu Parish—Continued*

Material	Thickness (feet)	Depth (feet)	Material	Thickness (feet)	Depth (feet)
<b>Cu-75. Firestone Tire and Rubber Co., Lake Charles</b> [Sec. 18, T. 10 S., R. 9 W.]					
Soil.....	2	2	Sand, fine.....	25	664
Clay.....	8	10	Shale.....	2	666
Sand, red.....	5	15	Sand.....	38	704
Clay.....	177	192	Shale.....	7	711
Sand.....	82	274	Sand.....	40	751
Shale.....	113	387	Shale.....	11	762
Sand.....	179	566	Sand, fine.....	21	783
Shale.....	73	639	Sand.....	114	897
<b>Cu-96. Petroleum Chemicals, Inc., Lake Charles</b> [Sec. 18, T. 10 S., R. 9 W.]					
Soil.....	2	2	Sand.....	167	561
Sand, red.....	28	30	Shale, gummy.....	37	598
Clay.....	20	50	Sand.....	15	613
Shale.....	152	202	Shale.....	7	620
Sand.....	28	230	Sand.....	116	736
Shale.....	164	394	Shale.....	20	756
<b>Cu-98. Petroleum Chemicals, Inc., Lake Charles</b> [Sec. 18, T. 10 S., R. 9 W.]					
Shale.....	200	200	Shale.....	49	391
Sand.....	35	235	Sand.....	166	557
Shale.....	55	290	Shale.....	47	604
Sand.....	52	342	Sand.....	163	767
<b>Cu-99. Columbia-Southern Chemical Corp., Lake Charles</b> [Sec. 3, T. 10 S., R. 9 W.]					
Clay, yellow.....	70	70	Sand, streaky, and gumbo.....	26	436
Sand, fine.....	6	76	Sand.....	98	534
Gumbo.....	78	154	Gumbo.....	20	554
Sand, coarse.....	7	161	Shale, sandy.....	10	564
Gumbo.....	9	170	Sand.....	105	669
Sand, coarse.....	100	270	Shale and sand.....	3	672
Gumbo.....	3	273	Sand.....	93	765
Sand.....	6	279	Shale, streaky.....	6	771
Gumbo.....	19	298	Sand.....	32	803
Shale, sandy.....	82	380	Gumbo.....	64	867
Sand.....	30	410			
<b>Cu-108. Union Oil of California, Lake Charles</b> [Sec. 33, T. 10 S., R. 12 W.]					
Soil.....	9	9	Sand.....	30	310
Gumbo, shells.....	15	24	Shale.....	86	396
Gumbo.....	62	86	Sand.....	19	415
Sand.....	34	120	Gumbo.....	195	610
Gumbo.....	160	280	Sand and gravel.....	58	668

TABLE 8.—*Drillers' logs of representative wells in Calcasieu Parish—Continued*

Material	Thickness (feet)	Depth (feet)	Material	Thickness (feet)	Depth (feet)
<b>Cu-112. I. V. Maurer, Westlake</b> [Sec. 25, T. 9 S., R. 9 W.]					
Soil.....	2	2	Shale.....	12	157
Clay.....	128	130	Sand, medium to		
Sand, fine.....	15	145	coarse.....	54	211
<b>Cu-114. F. P. Friesen, Lake Charles</b> [Sec. 20, T. 11 S., R. 8 W.]					
Soil.....	18	18	Sand, shale with		
Sand.....	30	48	shells.....	353	536
Clay.....	124	172	Sand, fine.....	37	573
Sand.....	11	183	Sand, coarse.....	129	702
<b>Cu-126. Swift Packing Co., Lake Charles</b> [Sec. 1, T. 10 S., R. 8 W.]					
Clay.....	38	38	Gumbo.....	212	415
Sand, coarse, yellow.....	9	47	Sand.....	42	457
Clay.....	142	189	Sand and gravel.....	53	510
Shale, sandy.....	14	203			
<b>Cu-135. Shell Oil Co., Lake Charles</b> [Sec. 6, T. 11 S., R. 9 W.]					
Soil.....	12	12	Gumbo.....	100	451
Sand, fine.....	5	17	Sand, fine.....	30	481
Clay.....	303	320	Sand, medium.....	45	526
Shale.....	31	351			
<b>Cu-136. Shell Oil Co., Lake Charles</b> [Sec. 23, T. 9 S., R. 7 W.]					
Clay.....	62	62	Sand, coarse, and		
Sand, fine.....	8	70	gravel.....	54	204
Clay.....	22	92	Sand, coarse, and		
Sand, fine, gray.....	58	150	gravel.....	39	243
<b>Cu-137. Shell Oil Co., Lake Charles</b> [Sec. 30, T. 9 S., R. 6 W.]					
Clay.....	17	17	Clay.....	55	84
Sand.....	12	29	Sand.....	222	306
<b>Cu-147. J. Metzger, Lake Charles</b> [Sec. 18, T. 10 S., R. 6 W.]					
Clay.....	15	15	Sand, coarse, gray.....	40	187
Sand, red.....	12	27	Sand, coarse, and		
Clay, yellow.....	80	107	gravel.....	169	356
Sand, fine, black.....	40	147	Gumbo, blue.....	3	359

TABLE 8.—*Drillers' logs of representative wells in Calcasieu Parish—Continued*

Material	Thickness (feet)	Depth (feet)	Material	Thickness (feet)	Depth (feet)
<b>Cu-156. O. Primo, Rt. 2, Iowa</b> [Sec. 35, T. 10 S., R. 7 W.]					
Soil, top-----	10	10	Sand, fine-----	90	291
Sand-----	8	18	Gravel-----	165	456
Clay, yellow-----	183	201			
<b>Cu-159. E. Fruge, Lake Charles</b> [Sec. 25, T. 11 S., R. 7 W.]					
Clay-----	10	10	Gumbo-----	25	175
Shells-----	6	16	Sand, hard, gray-----	140	315
Gumbo-----	99	115	Sand, coarse, white-----	115	430
Sand, hard, and shale	35	150			
<b>Cu-165. Walter Helm, Lake Charles</b> [Sec. 29, T. 11 S., R. 7 W.]					
Soil, surface-----	2	2	Clay, sandy-----	10	200
Clay-----	12	14	Sand-----	193	393
Sand, fine-----	8	22	Gumbo-----	7	400
Clay-----	128	150	Shale, hard, sand-----	6	406
Clay, streaky-----	40	190			
<b>Cu-172. E. Cobena, Lake Charles</b> [Sec. 2, T. 11 S., R. 8 W.]					
Soil-----	2	2	Clay and shale-----	305	390
Clay-----	6	8	Sand, fine-----	41	431
Sand, red-----	4	12	Shale, gummy-----	99	530
Clay-----	58	70	Sand, fine-----	14	544
Sand, fine, white-----	15	85	Sand-----	95	639
<b>Cu-173. C. Linkswiler, Lake Charles</b> [Sec. 26, T. 10 S., R. 8 W.]					
Soil, top-----	10	10	Clay, blue-----	55	438
Sand-----	24	34	Sand, fine, gray-----	91	529
Clay, blue-----	24	58	Clay, red-----	10	539
Sand, fine, gray-----	21	79	Sand, fine, gray-----	62	601
Clay, blue-----	64	143	Sand, gray-----	115	716
Sand, fine, gray-----	126	269	Sand and gravel-----	6	722
Clay, blue-----	20	289	Sand, coarse, gray-----	47	769
Sand, fine, gray-----	94	383			
<b>Cu-186. V. M. Jones, Lake Charles</b> [Sec. 35, T. 9 S., R. 8 W.]					
Gumbo-----	106	106	Sand-----	30	381
Sand, fine-----	22	128	Sand, white-----	133	514
Gumbo-----	223	351	Sand and gravel-----	138	652

TABLE 8.—*Drillers' logs of representative wells in Calcasieu Parish—Continued*

Material	Thickness (feet)	Depth (feet)	Material	Thickness (feet)	Depth (feet)
<b>Cu-208. W. Caldwell, Lake Charles</b> [Sec. 6, T. 8 S., R. 8 W.]					
Soil.....	12	12	Sand, fine.....	15	306
Clay.....	21	33	Gumbo.....	32	338
Sand, fine.....	8	41	Sand.....	4	342
Clay.....	67	108	Shale, sticky.....	9	351
Sand, red.....	18	126	Sand and gravel.....	116	467
Clay.....	165	291			
<b>Cu-216. Newport Industries, Lake Charles</b> [Sec. 18, T. 7 S., R. 10 W.]					
Clay, red.....	99	99	Gumbo.....	27	387
Clay, yellow.....	46	145	Shale, sandy.....	44	431
Gumbo.....	22	167	Gumbo.....	61	492
Sand and gravel.....	73	240	Shale, sandy.....	62	554
Rock.....	2	242	Sand, fine.....	51	605
Sand.....	46	288	Shale.....	21	626
Rock.....	1	289	Sand.....	5	631
Sand and gravel.....	71	360	Gumbo.....	22	653
<b>Cu-233. E. Wright, Lake Charles</b> [Sec. 1, T. 10 S., R. 12 W.]					
Soil.....	2	2	Shale, sandy.....	150	400
Clay, yellow.....	8	10	Gumbo.....	10	410
Sand.....	5	15	Sand, fine, gray.....	10	420
Sand, yellow.....	135	150	Sand, coarse, and gravel.....	110	530
Shale, sandy.....	40	190	Gumbo.....	5	535
Sand, fine, gray.....	60	250			
<b>Cu-241. T. S. Stegall, Lake Charles</b> [Sec. 34, T. 9 S., R. 11 W.]					
Soil.....	4	4	Shale.....	40	200
Sand.....	11	15	Sand, fine.....	70	270
Sand, white.....	35	50	Sand, coarse.....	110	380
Shale.....	10	60	Sand, coarse, and gravel.....	40	420
Gumbo.....	60	120			
Sand, fine.....	40	160			
<b>Cu-263. M. Drost, Lake Charles</b> [Sec. 3, T. 11 S., R. 10 W.]					
Soil.....	10	10	Sand, fine.....	15	280
Sand, red.....	5	15	Shale.....	45	325
Clay, yellow.....	120	135	Sand, fine.....	20	345
Shale.....	40	175	Shale.....	110	455
Shale, sandy.....	25	200	Sand, coarse, and gravel.....	110	565
Sand, fine.....	20	220			
Shale.....	45	265			



TABLE 8.—*Drillers' logs of representative wells in Calcasieu Parish—Continued*

Material	Thickness (feet)	Depth (feet)	Material	Thickness (feet)	Depth (feet)
<b>Cu-443. U.S. Air Force, Lake Charles</b> [Sec. 2, T. 10 S., R. 8 W.]					
Clay, sandy, red.....	48	48	Sand, coarse.....	40	364
Sand, coarse.....	12	60	Sand, medium.....	59	423
Gumbo.....	33	93	Sand, medium, coarse.....	67	490
Sand and gravel.....	7	100	Shale, sandy.....	23	513
Gumbo.....	40	140	Sand, hard.....	31	544
Clay.....	2	142	Shale and sand.....	23	567
Shale.....	103	245	Sand.....	118	685
Gumbo.....	59	304	Gumbo.....	16	701
Sand, fine.....	20	324			
<b>Cu-445. Cities Service Refining Corp., Lake Charles</b> [Sec. 18, T. 10 S., R. 9 W.]					
Soil.....	12	12	Gumbo and shale.....	130	389
Sand, red.....	28	40	Sand.....	153	542
Gumbo and shale.....	129	169	Shale.....	23	565
Sand.....	90	259			
<b>Cu-446. Cities Service Refining Corp., Lake Charles</b> [Sec. 18, T. 10 S., R. 9 W.]					
Soil.....	12	12	Sand.....	153	542
Sand, red.....	28	40	Gumbo and shale.....	58	600
Gumbo and shale.....	129	169	Sand.....	138	738
Sand.....	90	259	Gumbo.....	4	742
Gumbo and shale.....	130	389			
<b>Cu-447. Town of Maplewood</b> [Sec. 31, T. 9 S., R. 9 W.]					
Soil.....	2	2	Shale.....	98	218
Clay, sandy.....	10	12	Sand, shaly.....	18	236
Sand, red.....	18	30	Shale.....	144	380
Shale.....	20	50	Sand, medium.....	113	493
Clay.....	35	85	Shale.....	10	503
Sand, fine.....	35	120			
<b>Cu-449. Olin Mathieson Corp., Lake Charles</b> [Sec. 34, T. 9 S., R. 9 W.]					
Soil.....	3	3	Shale.....	107	367
Clay.....	48	51	Sand, fine.....	13	380
Shale.....	84	135	Sand, water.....	137	517
Sand.....	125	260	Gumbo.....	23	540
<b>CU-452. R. Royer, Lake Charles</b> [Sec. 23, T. 8 S., R. 12 W.]					
Soil.....	2	2	Shale, gumbo.....	26	248
Clay, sandy.....	38	40	Shale, gumbo.....	39	287
Sand.....	47	87	Shale, sandy.....	18	305
Shale and gumbo.....	68	155	Sand, fine, gray.....	30	335
Shale, sandy.....	45	200	Sand, medium, gray.....	89	424
Gumbo.....	4	204	Sand, coarse, and gravel.....	11	435
Sand, medium, white.....	18	222			

92 GEOLOGY AND GROUND WATER, CALCASIEU PARISH, LA.

TABLE 8.—*Drillers' logs of representative wells in Calcasieu Parish—Continued*

Material	Thickness (feet)	Depth (feet)	Material	Thickness (feet)	Depth (feet)
<b>Cu-453. C. Patterson, Lake Charles</b> [Sec. 34, T. 10 S., R. 10 W.]					
Soil.....	3	3	Shale, hard.....	90	170
Clay.....	12	15	Sand, fine.....	90	260
Sand.....	5	20	Sand.....	85	345
Shale.....	60	80			
<b>Cu-456. Paul Bellon, Gillis</b> [Sec. 22, T. 8 S., R. 8 W.]					
Clay.....	85	85	Shale, sandy.....	66	266
Sand.....	11	96	Sand, fine.....	43	309
Shale.....	59	155	Shale.....	4	313
Sand.....	8	163	Sand, medium.....	95	408
Shale.....	37	200	Sand, coarse.....	28	436
<b>Cu-462. Cit-Con Corp., Lake Charles</b> [Sec. 13, T. 10 S., R. 10 W.]					
Clay, white.....	15	15	Gumbo.....	59	399
Sand, fine.....	15	30	Sand, fine.....	159	558
Gumbo.....	134	164	Gumbo and shale.....	59	617
Sand, streaky.....	24	188	Sand, fine.....	68	685
Sand, fine.....	91	279	Sand and shale.....	12	697
Shale.....	51	330	Sand.....	36	733
Sand.....	10	340	Shale and gumbo.....	30	763
<b>Cu-486. Town of Westlake</b> [Sec. 26, T. 9 S., R. 9 W.]					
Soil.....	4	4	Shale, sandy.....	18	251
Clay, sandy.....	8	12	Shale.....	67	318
Sand.....	4	16	Shale, sandy.....	40	358
Clay.....	22	38	Sandy, fine.....	22	380
Shale.....	12	50	Shale.....	1	381
Sand.....	5	55	Sand.....	4	385
Shale.....	15	70	Sand, fine.....	64	449
Sand.....	3	73	Sand, medium.....	22	471
Shale, sticky.....	65	138	Sand, coarse.....	22	493
Sand.....	65	203	Sand, gravel.....	22	515
Shale.....	25	228	Sand, medium.....	6	521
Sand.....	5	233			
<b>Cu-498. J. E. Daigle, Lake Charles</b> [Sec. 28, T. 11 S., R. 8 W.]					
Soil.....	4	4	Shale, hard.....	126	450
Clay.....	14	18	Shale, sticky.....	10	460
Sand.....	4	22	Shale, sandy.....	29	489
Sand, fine.....	16	38	Shale.....	49	538
Clay, soft.....	49	87	Gumbo, hard.....	19	557
Sand, fine.....	11	98	Sand, fine.....	63	620
Gumbo.....	30	128	Sand and gravel.....	9	629
Shale, sticky.....	169	297	Sand, coarse.....	91	720
Sand, coarse.....	27	324	Sand, fine.....	60	780

TABLE 8.—*Drillers' logs of representative wells in Calcasieu Parish—Continued*

Material	Thickness (feet)	Depth (feet)	Material	Thickness (feet)	Depth (feet)
<b>Cu-510. L. Johnson, Sulphur</b> [Sec. 9, T. 9 S., R. 10 W.]					
Soil.....	3	3	Shale.....	180	300
Shale.....	87	90	Sand, fine.....	50	350
Sand, fine.....	30	120	Clay, sandy.....	100	450
<b>Cu-513. Ed. Stine, Lake Charles</b> [Sec. 19, T. 11 S., R. 10 W.]					
Soil.....	3	3	Shale, hard.....	143	200
Clay.....	12	15	Shale, sandy.....	323	523
Sand.....	7	22	Sand, fine.....	37	560
Shale.....	28	50	Sand and gravel.....	40	600
Sand.....	7	57			
<b>Cu-515. M. Ellender, Lake Charles</b> [Sec. 8, T. 11 S., R. 10 W.]					
Clay.....	30	30	Shale, gummy.....	129	398
Shale, gummy.....	35	65	Shale, sandy.....	35	433
Shale and gumbo.....	45	110	Sand, fine.....	55	488
Sand and shale.....	119	229	Sand, medium.....	89	577
Shale.....	40	269			
<b>Cu-518. Todd Bros., Lake Charles</b> [Sec. 3, T. 11 S., R. 7 W.]					
Soil.....	3	3	Clay.....	65	108
Clay.....	4	7	Gumbo.....	62	170
Sand, red.....	13	20	Sand, fine.....	50	220
Gumbo.....	23	43	Clay, sand.....	35	255
<b>Cu-530. M. Gray, Lake Charles</b> [Sec. 4, T. 11 S., R. 12 W.]					
Soil.....	4	4	Sand.....	50	431
Clay.....	8	12	Shale.....	4	435
Sand.....	11	23	Sand.....	21	456
Clay.....	22	45	Shale.....	2	458
Sand, coarse.....	30	75	Sand, fine.....	136	594
Sand.....	165	240	Shale.....	68	662
Sand, fine.....	93	333	Sand.....	83	745
Shale.....	48	381	Boulder.....	5	750
<b>Cu-534. W. Corbello, Lake Charles</b> [Sec. 6, T. 10 S., R. 12 W.]					
Soil.....	3	3	Sand, fine.....	19	244
Gumbo.....	44	47	Shale, hard.....	22	266
Shale.....	20	67	Sand.....	34	300
Sand.....	13	80	Shale.....	28	328
Shale, sticky.....	40	120	Sand.....	35	363
Sand.....	20	140	Shale.....	44	407
Shale, hard.....	30	170	Sand, fine.....	36	443
Shale, soft.....	30	200	Sand.....	7	450
Sand.....	19	219	Sand, good.....	57	507
Shale, hard.....	6	225	Sand, coarse.....	43	550

TABLE 8.—*Drillers' logs of representative wells in Calcasieu Parish—Continued*

Material	Thickness (feet)	Depth (feet)	Material	Thickness (feet)	Depth (feet)
<b>Cu-536. G. K. Rowlins, Gillis</b> [Sec. 8, T. 8 S., R. 8 W.]					
Clay, red	40	40	Shale	46	320
Sand, fine	40	80	Sand, fine	70	390
Shale	20	100	Shale	4	394
Gumbo	39	139	Sand	18	412
Shale	61	200	Shale	4	416
Gumbo and shale	50	250	Sand, coarse, and gravel	62	478
Shale, sandy	24	274			
<b>Cu-537. Country Club, Lake Charles</b> [Sec. 22, T. 10 S., R. 9 W.]					
Clay	20	20	Shale	180	680
Sand	10	30	Sand, fine	30	710
Shale	395	425	Shale	10	720
Sand, fine	75	500	Sand, coarse	40	760
<b>Cu-541. C. Reeves and Savol, Lake Charles</b> [Sec. 15, T. 9 S., R. 8 W.]					
Soil	3	3	Shale	290	350
Clay	52	55	Sand, fine	90	440
Sand	5	60	Clay, sand	45	485
<b>Cu-544. C. Cornett, Bell City</b> [Sec. 28, T. 10 S., R. 6 W.]					
Soil	3	3	Sand, fine	50	200
Clay	22	25	Sand, coarse	50	250
Sand	10	35	Gravel	27	277
Shale	115	150			
<b>Cu-555. Town of Vinton</b> [Sec. 15, T. 10 S., R. 12 W.]					
Clay	90	90	Sand	19	470
Sand	15	105	Clay	15	485
Clay	56	161	Sand	8	493
Unknown	9	170	Sand	4	497
Sand	125	295	Clay	7	504
Clay	95	390	Sand	94	598
Sand	30	420	Clay	2	600
Sand and clay	31	451	Sand	3	603
<b>Cu-569. A. Cormier, Lake Charles</b> [Sec. 23, T. 8 S., R. 13 W.]					
Clay, sandy	15	15	Sand	120	452
Sand, white	40	55	Sand, fine, sticky	38	490
Shale	277	332			
<b>Cu-570. J. Johnson, Lake Charles</b> [Sec. 33, T. 8 S., R. 11 W.]					
Clay	110	110	Shale, sandy	66	294
Sand, medium	46	156	Sand, medium	106	400
Shale, gummy	72	228			

TABLE 8.—*Drillers' logs of representative wells in Calcasieu Parish—Continued*

Material	Thickness (feet)	Depth (feet)	Material	Thickness (feet)	Depth (feet)
<b>Cu-572. Stein and Kinney, Starks</b> [Sec. 12, T. 9 S., R. 13 W.]					
Soil.....	4	4	Sand.....	5	225
Clay.....	53	57	Shale.....	112	337
Sand, fine.....	8	65	Sand, fine.....	73	410
Sand, coarse.....	20	85	Sand, medium.....	16	426
Sand, gravel.....	8	93	Sand, coarse.....	24	450
Shale, sandy.....	77	170	Gravel.....	43	493
Sand, fine.....	33	203	Sand.....	19	512
Shale.....	17	220	Shale.....	3	515
<b>[Cu-621. Stein and Kinney, Starks</b> [Sec. 31, T. 11 S., R. 11 W.]					
Soil.....	5	5	Shale.....	87	407
Gumbo.....	112	117	Gumbo.....	58	465
Gumbo.....	54	171	Sand.....	120	585
Sand, coarse.....	37	208	Sand, coarse.....	90	675
Gumbo.....	112	320	Gumbo.....	4	679
<b>Cu-625. Stein and Kinney, Starks</b> [Sec. 11, T. 8 S., R. 13 W.]					
Soil.....	4	4	Sand, fine.....	50	380
Clay.....	67	71	Sand, coarse, and gravel.....	80	460
Sand.....	39	110			
Shale.....	220	330			
<b>Cu-632. Mr. Coffey, Lake Charles</b> [Sec. 22, T. 8 S., R. 9 W.]					
Soil, and clay.....	75	75	Shale.....	10	214
Sand.....	129	204			
<b>Cu-637. J. Lamkin and K. Breaux, Lake Charles</b> [Sec. 27, T. 11 S., R. 8 W.]					
Soil.....	6	6	Shale, sandy.....	80	280
Sand, red.....	9	15	Sand.....	47	327
Clay, red.....	20	35	Shale.....	57	384
Clay, blue.....	25	60	Shale, sandy.....	77	461
Clay, sandy.....	60	120	Sand.....	124	585
Shale.....	80	200			
<b>Cu-641. Prairie Canal Co., Lake Charles</b> [Sec. 12, T. 11 S., R. 8 W.]					
Clay.....	8	8	Sand, fine.....	40	260
Sand.....	12	20	Sand, coarse.....	50	310
Shale.....	140	160	Sand, coarse, and gravel.....	61	371
Sand, fine.....	30	190			
Shale.....	30	220			

TABLE 8.—*Drillers' logs of representative wells in Calcasieu Parish—Continued*

Material	Thickness (feet)	Depth (feet)	Material	Thickness (feet)	Depth (feet)
<b>Cu-646. J. Metzger, Iowa</b> [Sec. 18, T. 10 S., R. 6 W.]					
Soil.....	1	1	Shale.....	97	115
Clay.....	13	14	Sand, fine.....	120	235
Sand.....	4	18	Sand, coarse.....	95	330
<b>Cu-651. D. W. Abbott, Welch</b> [Sec. 29, T. 9 S., R. 6 W.]					
Soil.....	3	3	Shale.....	110	240
Clay.....	22	25	Sand, fine.....	60	300
Sand.....	5	30	Sand, coarse.....	20	320
Clay.....	100	130	Sand and gravel.....	80	400
<b>Cu-653. Krause and Managan, Sulphur</b> [Sec. 11, T. 9 S., R. 10 W.]					
Soil.....	2	2	Clay, brown, blue, gray, white with shell fragments.....	51	315
Clay, gray, buff.....	8	10	Sand, fine, black, red, green.....	42	357
Clay, gray.....	10	20	Sand, fine to coarse.....	33	390
Clay, brown.....	10	30	Clay.....	10	400
Clay, brown, grayish, silty.....	10	40	Clay, red, blue, brown, lignitic.....	20	420
Clay, brown, red, sandy.....	10	50	Wood, carbonized.....	3	423
Clay, brown, red, lig- nitic.....	10	60	Sand, coarse, and gravel.....	63	486
Clay, brown, red.....	20	80	Sand, coarse, and gravel with wood.....	22	508
Clay, gray, red.....	110	210	Sand, coarse, and gravel.....	20	528
Clay, red, gray, brown, lignitic.....	23	233	Sand, fine to medium. Sand, coarse, and gravel.....	20	548
Sand, fine to medi- um, white to gray- ish, salt and pep- per.....	17	250	Clay, blue.....	5	553
Clay, brown, blue.....	14	264		15	568
<b>Cu-654. Continental Oil Co., Lake Charles</b> [Sec. 27, T. 9 S., R. 9 W.]					
No log.....	50	50	Clay.....	135	420
Clay.....	105	155	Sand.....	145	565
Sand and gravel.....	130	285			
<b>Cu-655. City of Sulphur, Sulphur</b> [Sec. 34, T. 9 S., R. 10 W.]					
Surface.....	2	2	Sand.....	112	390
Clay.....	246	248	Clay.....	2	392
Sand and shale.....	12	260	Sand.....	188	580
Sandy shale.....	18	278	Sandy shale.....	92	672

TABLE 8.—*Drillers' logs of representative wells in Calcasieu Parish—Continued*

Material	Thickness (feet)	Depth (feet)	Material	Thickness (feet)	Depth (feet)
<b>Cu-666. Gulf States Utilities Corp., Lake Charles</b> [Sec. 9, T. 9 S., R. 9 W.]					
Soil.....	14	14	Sand, fine.....	100	990
Sand.....	8	22	Shale, sandy.....	280	1, 270
Clay, yellow.....	173	195	Sand, fine.....	11	1, 281
Sand, coarse.....	25	220	Shale, sticky.....	219	1, 500
Gumbo.....	100	320	Sand.....	55	1, 555
Sand, good.....	270	590	Gumbo.....	38	1, 593
Rock, lime.....	10	600	Sand.....	27	1, 620
Sand, hard.....	90	690	Shale, sandy.....	270	1, 890
Sand and shale.....	130	820	Shale, streaky.....	130	2, 020
Shale, sandy.....	70	890	Gumbo.....	184	2, 204

TABLE 9.—*Wells used in fence diagram*

Fence diagram	Well designation	Location		
		Sec.	Township	Range
1.....	Cu-625.....	11	8 S.	13 W.
2.....	Sun Oil Co.....	1	8 S.	10 W.
3.....	Cu-216.....	18	7 S.	10 W.
4.....	Union Sulphur Co.....	34	7 S.	10 W.
5.....	Shell Oil Co.....	6	8 S.	9 W.
6.....	Union Sulphur Co.....	32	7 S.	7 W.
7.....	Continental Oil Co.....	30	7 S.	6 W.
8.....	Humble Oil Co.....	19	6 S.	9 W.
9.....	Placid Oil Co.....	20	9 S.	7 W.
10.....	Cu-587.....	31	9 S.	8 W.
11.....	Cu-92.....	34	9 S.	9 W.
12.....	Cu-653.....	11	9 S.	10 W.
13.....	Union Prod. Co.....	21	8 S.	10 W.
14.....	Union Sulphur Co.....	30	9 S.	10 W.
15.....	Gulf Ref. Co.....	19	9 S.	11 W.
16.....	Jefferson Lake Sulphur Co.....	19	9 S.	12 W.
17.....	Sexton Oil Co.....	18	10 S.	12 W.
18.....	Ohio Oil Co.....	20	11 S.	13 W.
19.....	Magnolia Petroleum Co.....	1	12 S.	12 W.
20.....	Union Sulphur Co.....	21	11 S.	10 W.
21.....	Stanolind Oil and Gas Co.....	17	11 S.	9 W.
22.....	Hankamer Ins. Co.....	32	10 S.	9 W.
23.....	Cu-446.....	18	10 S.	9 W.
24.....	Shell Oil Co.....	16	11 S.	8 W.
25.....	Cu-493 and Cu-151.....	29	10 S.	7 W.
26.....	Sohio Oil Co.....	30	10 S.	6 W.
27.....	Cu-655.....	34	9 S.	10 W.

## REFERENCES

- Bennett, R. R., and Meyer, R. R., 1952, Geology and ground-water resources of the Baltimore area: Maryland Dept. Geology, Mines and Water Resources Bull. 5, 573 p.
- Fader, S. W., 1954, An analysis of contour maps of water levels in wells in southwestern Louisiana, 1952 and 1953: Louisiana Dept. Conserv., Geol. Survey, and Louisiana Dept. Public Works, Water Res. Pamph. 1.
- 1955, An analysis of contour maps of water levels in wells in southwestern Louisiana, 1954: Louisiana Dept. Conserv., Geol. Survey, and Louisiana Dept. Public Works, Water Res. Pamph. 2.
- 1957, An analysis of contour maps of water levels in wells in southwestern Louisiana, 1955: Louisiana Dept. Conserv., Geol. Survey, and Louisiana Dept. Public Works, Water Res. Pamph. 4.
- Fenneman, M. N., 1938, Physiography of eastern United States: New York and London, McGraw-Hill Book Co., Inc., 714 p.
- Ferris, J. G., 1948, Ground-water hydraulics as a geophysical aid: Michigan Dept. Conserv. Tech. Rept. 1, 11 p.
- Fisk, H. N., 1940, Geology of Avoyelles and Rapides Parishes: Louisiana Dept. Conserv., Geol. Survey Bull. 18, 240 p.
- 1944, Geological investigation of the alluvial valley of the lower Mississippi River: U.S. Dept. Army, Mississippi River Comm., 89 p.
- Harris, G. D., Veatch, A. C., and others, 1905, Underground waters of southern Louisiana: Louisiana Dept. Conserv., Geol. Survey Bull. 1, 79 p., pt. 1.
- Howe, H. V., Russell, R. J., and McGuirt, J. H., 1935, Reports on the geology of Cameron and Vermilion Parishes: Louisiana Dept. Conserv., Geol. Survey Bull. 6, 242 p.
- Jones, P. H., 1950, Ground water in the Lake Charles area, Louisiana: U.S. Geol. Survey open-file report.
- Jones, P. H., Hendricks, E. L., Ireland, B., and others, 1956, Water resources of southwestern Louisiana: U.S. Geol. Survey Water-Supply Paper 1364, 460 p.
- Jones, P. H., Turcan, A. N., Jr., and Skibitzke, H. E., 1954, Geology and ground-water resources of southwestern Louisiana: Louisiana Dept. Conserv., Geol. Survey Bull. 30, 285 p.
- Maxcy, K. F., 1950, Report on the relation of nitrates in well waters and the occurrence of methemoglobinemia: Natl. Research Council, Bull. San. Eng., p. 265, app. D.
- Meinzer, O. E., 1923, The occurrence of ground water in the United States, with a discussion of principles: U.S. Geol. Survey Water-Supply Paper 489, 321 p.
- Meyer, R. R., and Turcan, A. N., Jr., 1955, Geology and ground-water resources of the Baton Rouge area, Louisiana: U.S. Geol. Survey Water-Supply Paper 1296, 138 p.
- Piper, A. M., Garrett, A. A., and others, 1953, Native and contaminated ground waters in the Long Beach-Santa Ana area, California: U.S. Geol. Survey Water-Supply Paper 1136, 320 p.
- Sayre, A. N., 1937, Geology and ground-water resources of Duval County, Tex.: U.S. Geol. Survey Water-Supply Paper 776, 116 p.
- Theis, C. V., 1935, The relation between the lowering of the piezometric surface and the rate and duration of discharge of a well using ground-water storage: Am. Geophys. Union Trans., pt. 2, August, p. 519-524.



- Thompson, D. G., 1928, Ground-water supplies of the Atlantic City region: New Jersey Dept. Conserv. and Devel., Div. Water Bull. 30, 138 p.
- U.S. Public Health Service, 1946, Public Health Service drinking water standards: Public Health Repts., v. 61, no. 11, p. 371-384.
- Wenzel, L. K., 1942, Methods for determining permeability of water-bearing materials, with special reference to discharging-well methods, with a section on direct laboratory methods and bibliography on permeability and laminar flow, by V. C. Fishel: U.S. Geol. Survey Water-Supply Paper 887, 192 p.
- Winslow, A. G., and Doyle, W. W., 1954, Salt water and its relation to fresh ground water in Harris County, Tex.: Texas Board Water Engineers Bull. 5409.



# INDEX

	Page		Page
Acknowledgments.....	4-5	Chicot aquifer—Continued	
Agriculture.....	2, 40	"700-foot"—Continued	
Allen Parish.....	10, 22, 25, 31, 37, 39	summary of characteristics.....	64-65
Aquiclude, definition.....	13	thickness.....	34
Aquifer, definition.....	12-13	transmissibility coefficient.....	17, 35
Aquifers, table.....	8	water-level changes.....	53-55
Beauregard Parish.....	2, 10, 22, 23, 25, 27, 31, 37, 39	yield, table.....	35, 66-81
Bentley formation.....	8	Chicot reservoir.....	10
Bentley terrace.....	9	Chloride content of water.....	58
Calcasieu River.....	2, 3, 6, 9, 22, 27, 44	Exploratory methods.....	60-63
Cameron Parish.....	2, 34, 57	Construction of wells.....	60-63
Cascadian revolution.....	11	Contamination, corrective measures.....	59
Catahoula formation.....	8, 11	Darcy's law.....	49
Chemical analyses, ground water.....	82-85	Depositional terraces.....	9
Chicot aquifer, "200-foot," chemical analyses		DeQuincy.....	2, 5, 9, 11, 25, 26, 31, 34, 39, 56
of water.....	82-83	DeRidder.....	39
"200-foot," distribution.....	27	Discharge.....	22
drawdown.....	29	Drainage.....	5-6
hydrographs.....	42	Drawdown.....	14-15, 18-19, 29
lithology.....	27	<i>See also under aquifer names.</i>	
permeability.....	16, 28	Drill-stem tests, in exploration for water.....	60
pumpage.....	43-44	Edgerly.....	32
quality of water.....	29-30	Edgerly field.....	11
specific capacity.....	28	Electrical logs, in exploration for water.....	56, 60
storage coefficient.....	16, 28-29	Evangeline aquifer, description.....	10
summary of characteristics.....	64	discharge.....	22
thickness.....	27	distribution.....	37, 39
transmissibility coefficient.....	16, 28-29	lithology.....	37
water-level changes.....	44	permeability.....	39
yield, table.....	28, 66-81	quality of water.....	39
"500-foot," chemical analyses of water.....	83-85	recharge.....	22-23
distribution.....	30-32	specific capacity.....	19
drawdown.....	32-34	thickness.....	11, 37, 39
hydrographs.....	46, 47, 48	yield.....	66-81
lithology.....	31-32	Evangeline Parish.....	10, 22, 25, 37, 39
permeability.....	16, 32	Faults.....	11-12
piezometric map, analyses.....	45-52, pl. 5	Field coefficient of permeability, definition.....	13
pumpage.....	44	Fleming formation.....	8, 11
quality of water.....	34	Foley formation.....	8, 10, 39
specific capacity.....	32	Fossils.....	8, 10, 11
storage coefficient.....	16, 32	Gravel-pack wells.....	61
summary of characteristics.....	64	Ground water, adequacy of supply.....	3
thickness.....	30-31	calculation of rate of movement.....	51-52
transmissibility coefficient.....	16, 32	definition.....	12
water-level changes.....	44-45	depth of occurrence.....	56
yield, table.....	32, 66-81	mineral matter.....	23
"700-foot," chemical analyses of water.....	85	movement.....	49, 51-52
distribution.....	34	occurrence.....	12-13, 25
drawdown.....	35-37	source.....	12
hydrographs.....	54, 55	temperature.....	24-25
lithology.....	34-35	value to industry.....	3
pumpage.....	53	<i>See also under aquifer names.</i>	
quality of water.....	37, 38	Gulf-coast geosyncline.....	11
specific capacity.....	35	Gulf Coastal Plain.....	8, 9
storage coefficient.....	17, 35	Holmwood area.....	27, 28, 29, 44

	Page		Page
Houston River.....	5, 6, 9, 11, 27, 56	Rapides Parish.....	22
Hydraulic characteristics.....	13	Recent deposits, general geology.....	8, 9
Hydraulic gradient, reversal.....	57	water-bearing properties.....	25, 26
Hydraulic-rotary drilling method.....	60-61	Recharge.....	22-23, 43
Industrial water supply.....	3, 26, 28, 32, 34, 40, 43, 44, 45, 53, 60, 63	References.....	98-99
Industry in the parish.....	2	Reiser's Machine Shop well.....	43
Investigations, previous.....	4	Reverse-rotary drilling method.....	61
Investigation, purpose and scope.....	3-4	Rock formations and their water-bearing properties.....	25-40
Iowa.....	31, 44, 56	Rural water supply.....	3, 26, 40, 43, 60, 64
Iowa field.....	11	Sabine River.....	2, 5, 6, 9
Irrigation, acreage.....	41	Salt domes.....	11-12, 59
Irrigation water supply.....	3, 26, 28, 32, 34, 40, 41, 44, 45, 53, 60, 62, 63	Salt water, lateral movement.....	57-58
Irrigation wells, typical construction.....	62	movement in vicinity of structures.....	59
Jefferson Davis Parish.....	2	source.....	56
Jet pumps.....	63	summary.....	65
Lake Charles.....	2, 3, 4, 10, 26, 34, 35, 37, 44, 53, 63, 64	vertical movement.....	58-59
Lake Charles Air Force Base.....	26	Shallow sands.....	26-27
Lake Charles industrial district.....	2, 10	Specific capacity, definition.....	19-20
Lift, methods of.....	63	Spontaneous potential curve.....	60
Location and general features of area.....	2-3	Starks dome.....	11-12, 59
Lockport oil field.....	11, 58	Starks field.....	11, 56
Logs of wells.....	86-97	Storage coefficient, definition.....	13
Minerals, concentrations in water.....	23-24	<i>See also under aquifer names.</i>	
Miocene deposits, general geology.....	11	Sulphur.....	27, 32, 34, 56
water-bearing properties.....	25, 40	Sulphur Mines oil field.....	11, 58
Montgomery formation.....	8	Summary.....	63-65
Montgomery terrace.....	9	Temperature average annual.....	6
Moss Lake.....	2, 34	ground water.....	24-25
Municipal water supply.....	3, 26, 28, 32, 34, 35, 40, 44, 45, 60, 63	Test holes, in exploration for water.....	60
Natural-pack wells.....	61-63	Theis nonequilibrium formula.....	14-15
Orange, Tex.....	32	Topography.....	5
Piezometric map, analysis.....	45, 49-52	Transmissibility, calculation.....	49-51
Piezometric surface, decline.....	52	coefficient, definition.....	13
definition.....	13	Darcy's law.....	49
Pleistocene deposits, general geology.....	8, 9-10	effect on drawdown.....	18
water-bearing properties.....	25, 26-37	<i>See also under aquifer names.</i>	
<i>See also under aquifer names.</i>		Transportation.....	2-3
Pliocene deposits, general geology.....	10-11	Turbine pumps.....	63
water-bearing properties.....	25, 37-39	Vegetation.....	5-6
Population.....	2	Vinton field.....	11
Prairie formation.....	8	Vinton, La.....	30, 32
Prairie terrace.....	9	Water-level fluctuations.....	20-21, 65
Pumping, effects of.....	44, 45, 53	<i>See also under aquifer names.</i>	
Pumping tests.....	13-19	Water table, definition.....	12
Quality of water, mineral matter.....	23-24	Wells construction and methods of lift.....	60-63
<i>See also under aquifer names.</i>		defective.....	59
Rainfall, average annual.....	6, 7	description.....	65-81
relation to pumpage for irrigation.....	40-41	logs.....	86-97
source of recharge.....	22	numbering system.....	5
		West Gulf Coastal Plain.....	5
		Westlake.....	28, 29, 43, 44, 53
		Williana formation.....	8