

DEPARTMENT OF THE INTERIOR

---

BULLETIN

OF THE

UNITED STATES

GEOLOGICAL SURVEY

No. 35



WASHINGTON  
GOVERNMENT PRINTING OFFICE  
1886



UNITED STATES GEOLOGICAL SURVEY

J. W. POWELL, DIRECTOR

---

PHYSICAL PROPERTIES

OF

THE IRON-CARBURETS

THIRD PAPER

(PRECEDING PAPERS ON THE IRON-CARBURETS IN BULLETINS 14 AND 27)

BY

CARL BARUS AND VINCENT STROUHAL



WASHINGTON  
GOVERNMENT PRINTING OFFICE  
1886

# CONTENTS.

---

	Page.
Letter of transmittal.....	10
A. The internal structure of tempered steel.....	11
Introduction.....	11
Apparatus.....	12
Experimental results.....	16
Discussion.....	31
Conclusion.....	50
B. The color effect produced by slow oxidation of iron-carburets.....	51
Data for high temperature.....	52
Data for low temperature.....	55
Index.....	61



## ILLUSTRATIONS.

---

	Page.
<b>FIG. 1.</b> Crucible for heating steel.....	13
2. Apparatus for quenching steel.....	14
3. Holder for galvanic solution.....	15
4. Method of suspension.....	16
5. Rod No. 1 after removal of seven shells.....	28
6. Holder for resistance measurements.....	29
7. Chart illustrating density as a function of radius.....	33
8. Chart illustrating elementary density as a function of radius.....	36
9. Chart showing temperature of the mean "clear blue" film, as a function of time.....	54
10. Grunow's shaft in position.....	59



## LETTER OF TRANSMITTAL.

---

DEPARTMENT OF THE INTERIOR,  
UNITED STATES GEOLOGICAL SURVEY,  
DIVISION OF CHEMISTRY AND PHYSICS,  
*Washington, D. C., January 18, 1886.*

SIR: We have the honor to transmit, through Prof. F. W. Clarke, chief chemist, the accompanying paper on the physical properties of the iron-carburets for publication as a bulletin of the Survey. The paper is offered in its present fragmentary form, owing to the circumstance that certain changes in the location of the laboratory oblige us temporarily to suspend the work. The results here presented, however, advance the inquiry to well defined stages of research, and we therefore have no hesitation about submitting them.

Our earlier work on the iron-carburets will be found in Bulletin 14 and in Bulletin 27, pp. 30 to 61.

C. BARUS.  
V. STROUHAL.

Hon. J. W. POWELL,  
*Director United States Geological Survey.*

(451)

9





# PHYSICAL PROPERTIES OF THE IRON-CARBURETS.

BY CARL BARUS AND VINCENT STROUHAL.

## A. THE INTERNAL STRUCTURE OF TEMPERED STEEL.

### INTRODUCTION.

Theories of magnetization usually premise homogeneity of the material carrying the magnetic quality. If the material is homogeneous, such theories still encounter formidable mathematical difficulties, and even in the favorable case of soft steel they fail to predict results which are in satisfactory accordance with experiments.<sup>1</sup> In proportion as the rods become hard and the internal structure becomes more and more complex, the phenomena are withdrawn from the scope of theory altogether, and must be grouped and described by a series of empiric laws. It is clear, however, that a decided step in advance of mere empiricism will have been made when the conditions of internal structure shall be fully understood. The present paper is a first endeavor in this direction. We may add that what is here said respecting magnetism will apply to other properties of steel.

In our magnetic work<sup>2</sup> we operated upon very thin steel rods, inferring that where diameter decreases indefinitely structure will more and more completely vanish; but to what degree this assumption is warranted for diameters within the reach of experimental methods cannot be foreseen. In other words, we do not know to what extent our results fail to express the permanent magnetization of steel, passing *homogeneously* from hard to soft. Even if it be granted that the error due to surface decarburation is nil, we have still to take into account the structural effects originally observed by Fromme.<sup>3</sup> We have digested his results in the accompanying table, and from these computed a few supplementary data to give the table fullness. The latter are inclosed in parentheses. In the table,  $M, \rho, \Delta$  denote the mass in grammes, the radius in centimeters, and the density, respectively, of the given glass-hard rod, after the removal of the number of shells indicated in the first column. The mean radius, thickness, mass, and density of

<sup>1</sup> Cf. U. S. Geol. Surv. Bull. 14, pp. 113, 114.

<sup>2</sup> Bull. 14, chaps. V, VI.

<sup>3</sup> C. Fromme: Wied. Ann., VIII, p. 355, 1879.

the consecutive shells are given under  $R$ ,  $S$ ,  $\mu$ ,  $\delta$ . The second column contains the number of days during which the rod was left in dilute acid to effect the removal of shells. Fromme determined  $\Delta$  once per day. We may remark that the rod used was twice glass-hardened, and that after losing the three shells mentioned, it showed internal fissures. This led Fromme to abandon the experiment.

*Table showing Fromme's results for structure.*

Shell.	Days.	M	$\rho$	$\Delta$	$R$	$S$	$\mu$	$\delta$
0.....	0	30.450	(0.3537)	7.7487	.....	.....	.....	.....
1.....	9	29.746	(0.3504)	7.7130	(0.3520)	(0.0033)	0.704	10.5
2.....	16	28.043	(0.3396)	7.7412	(0.3450)	(0.0108)	1.703	7.3
3.....	20	27.029	(0.3340)	7.7120	(0.3368)	(0.0056)	1.014	(8.6)

It is to us a matter of no little surprise that after having obtained these startling results, the significance of which Fromme fully appreciated, he should have given the work no further consideration. The surface densities here encountered are almost incredibly large, especially so because the rod, having been twice quenched, must have been superficially decarburized, and because it was internally cracked. And yet, in spite of the dangerously small values of  $S$ , the values for  $\Delta$  are so pronounced that the data for  $\delta$  must in their general variations be correct. Hence these abnormal values, and the probable occurrence of changes of strain implied, together with intimations of singular periodic relations, give this short series of results unusual physical importance.

Guided by these data, many of our experiments were made chiefly with reference to surface effects. Nevertheless, our main object in this paper is to follow the phenomenon of structure throughout comparatively great ranges of depth. Hence our shells are necessarily<sup>1</sup> chosen thicker (0.01<sup>cm</sup> to 0.1<sup>cm</sup>), and for this reason, possibly, we did not detect the enormous condensation of Fromme's filmy shells, if, indeed, in the steel examined such densities existed. Aside from this difference in degree, in the method chosen, and in the material employed our results corroborate the data of Fromme in a general way. We also encounter harmonic variations of  $\delta$  which appear to be actual occurrences, inasmuch as they cannot satisfactorily be referred to periodic distributions of errors.

#### APPARATUS.

*Steel.*—Our steel, as we subsequently found, was not the best for the purpose, being a coarse-grained metal, quite brittle in the glass-hard state. This steel readily cracks on quenching, easily loses carbon at the surface, and is probably incapable of carrying more than small values of stress. If the temperature before quenching be too high, the

<sup>1</sup>It is impossible to retain perfect cylindricality when many shells are removed by solution. See p. 49.

superficial layers rarely show hardness at all. All this taken together may explain why the values of density in hand vary within an interval so much smaller than was the case in Fromme's investigation. Some of our experiments, however, were made with other kinds of steel. *A priori* there is no reason why results for the structure of the material in question are not just as important as results for the structure of any other kind of steel. The objectionable qualities enumerated have indeed led to some special results. We show in the sequel that the chemical constitution of steel is one of the essential factors determining structure; that in a full investigation it will be necessary to extend the experiments to as many kinds of steel as possible.

In all cases, however, the mechanical hardness exhibited by our steel in the tempered state was exceptionally great. Moreover, the density interval hard-soft is here as large as we have found it in any other kind of steel. It appears, indeed, that the magnitude of this interval is modified chiefly by carburization, and that for moderate thicknesses it is almost independent of dimensions—a deduction at variance with earlier results of Fromme and our own. Cylindrical figures were operated on in all cases.

*Crucible.*—To impart to the thick steel cylinders the desirable uniformity of red heat before quenching, they were heated in a cylindrical iron box (height 8.5cm, diameter 4cm, inside measure) made of gas-pipe supplies. The box was heavily coated with oxide internally, and the cylinder was placed therein on a layer of asbestos, as shown in Fig. 1.

This apparatus is introduced into a large Fletcher crucible furnace and heated to the degree of redness necessary. The temperature of the cylinder must be specially observed from time to time by momentary removals of the lid. The iron box is further useful, inasmuch as oxidation, carburization, and decarburization are very nearly avoided. The surfaces of the cylinders remain smooth, showing the colored films only.

*Apparatus for quenching.*—This apparatus is also made of gas-pipe supplies, as shown in Fig. 2. When in use it is placed vertically in the neighborhood of a hydrant, and a swift current of water is passed through it, as indicated by the arrows. Dimensions of main reservoir: Length, 25cm; diameter, 5cm, inside measure. Diameter of supply-tube, 2.5cm. Near the lower end of the apparatus is a false bottom of wire gauze, *a a*, held in place by an iron ring. The object of this is to hold the steel suspended in the current. The cylinder, having been

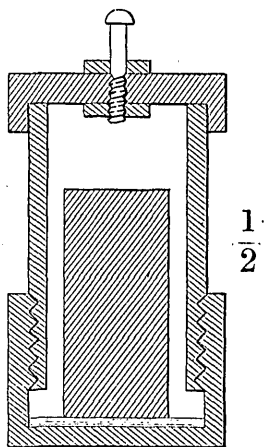

FIG. 1. Crucible for heating steel.

heated to the temperature desired, is carried to the quencher in the (closed) crucible; after this the lid is quickly taken off, and the cylinder is dropped into the water. The advantages and disadvantages of quenching in a current of water have so frequently been discussed that comment is unnecessary here. It is certainly the best method for the present purposes.

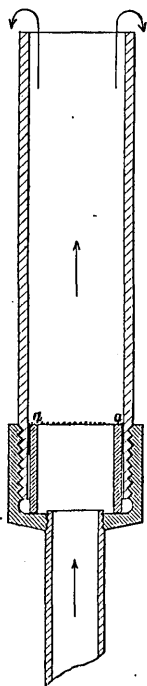

FIG. 2. Apparatus for quenching steel.

*Cell for solution.*—For the purpose of removing consecutive shells from the cylinder, we tried at first to use a carbon-pointed master-tool on the lathe. But steel is too tenacious and diamond too brittle; so that even in the case of stones ground with sharp cutting edges the work is rather scraped or ground than cut. The progress made is therefore exceedingly slow, and the utmost care must be taken to avoid appreciable rise of temperature from friction. This tedious process was therefore rejected, and a method in which the shells are removed by galvanic solution was used in its stead. After solution the cylinders were trued and smoothed as far as necessary by the diamond point, scraping under a current of water.

In order to secure uniformity of solution over the whole cylindrical surface of the steel, we devised the special cell figured in the diagram, Fig. 3 (page 15).

This consists essentially of a steel clamp,  $c a b d e c$ , the ends of which are sharpened conically, and fit into conical depressions,  $c c$ , in the end surfaces of the cylinder operated upon. A drum,  $A B D E$ , the cylindrical surface of which is of sheet copper, with the ends  $A B$  and  $D E$  closed by plates of suitably perforated vulcanite, surrounds the cylinder symmetrically on all sides. The steel arm  $a c$  passes through the center of the upper plate. The lower plate has a much larger perforation, enabling the drum to slide easily over the cylinder and fitted to a wooden collar,  $F F$ .

Together with the side of clamp  $e d$ , the collar  $F F$  serves as a kind of foot for the apparatus. When in use the cell is plunged into a large vessel containing the electrolyte, and is submerged at least above the upper face  $A B$  of the drum. To prevent corrosion, the clamp  $c a b d e c$  is completely enveloped in an insulating coat of rubber hose. For the same purpose the ends of the cylinder are painted with asphaltum. Having sprung it into position, the insulation of the clamp is made continuous with the insulation on the ends of the cylinder by covering all exposed parts with a thick layer of paraffine.

The current enters the clamp at  $+a$ , passing into the cylinder from both ends; thence across the electrolyte to the drum; finally by the gutta-percha-covered wire  $B-$  back to the battery. It is well to cover

the *inner* surface of the drum, above the upper and below the lower planes of the ends of the cylinder, with asphaltum. In this case the axes of the tubes of flow are radial lines. In other cases they are crowded either near the ends or near the equatorial parts of the cylinder, and solution takes place at greater rates in those parts.

Two to ten Grove cells, flat pattern, vulcanite cups, connected either in series or in multiple arc, supplied the amount of current necessary. These cells are by no means constant, and are practically exhausted for the present purposes in two hours. The quantity of steel dissolved without current being slight, we were able to supervise and regulate the rate of solution satisfactorily by inserting a Siemens' amperimeter. The whole process was therefore well under control. Usually the strength of current was so chosen as to dissolve an average total amount of 10 g. to 15 g. during each experiment.

The following little table, selected at random from many data, contains the statistics of solution and exhibits the mean efficiency of the battery (current in amperes) perspicuously:

Time.		Current.	Time.		Current.
<i>h.</i>	<i>m.</i>		<i>h.</i>	<i>m.</i>	
10	10	3.0	10	55	10.5
	15	8.7		60	9.3
	20	11.0	11	5	8.4
	25	12.2		10	7.4
	30	12.8		15	6.9
	35	13.0		25	5.8
	40	12.8		45	3.6
	45	12.2	12	15	0.5
	50	11.3			

During the solution of superficial shells the cylinders frequently showed symmetrical furrows and ridges, probably indicative of certain varieties of structure of the soft bars. Usually, however, the surfaces were merely rough and pitted, heavily coated with carbon, somewhat

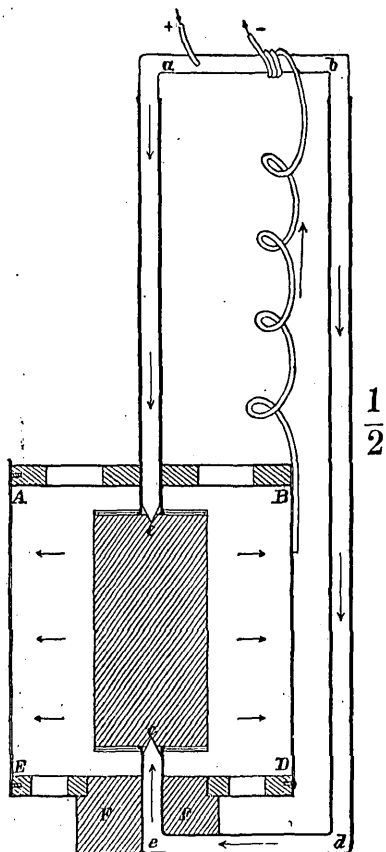

FIG. 3. Holder for galvanic solution.

irregular; so that truing with the diamond is indispensable. In some rare instances glossy surfaces appeared, or again rough surfaces partially mottled with glossy patches. All this is probably connected with the passivity of iron. Solution is best effected in dilute hydrochloric acid. In the case of dilute sulphuric acid the occurrence of passive iron and reduced rates of solution are a frequent annoyance. The ferric chlorides attack copper, and are therefore objectionable. Solution in oxalates, though distinctly perceptible, is practically nil.<sup>1</sup>

The central depressions or holes in the end surfaces of the steel cylinders have thus far been described only as subserving the purposes of holding the cylinders in the dissolving cells, and (during truing) in the lathe. But they are further useful, in the density work in question, as a means for attaching the suspension. This is clearly shown in the annexed cut, Fig. 4. This method of fastening is again employed in the resistance measurements.

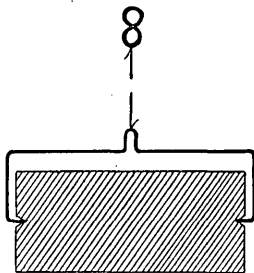

FIG. 4.—Method of suspension.

#### EXPERIMENTAL RESULTS.

*Results for density.*—The results of our measurements are given in the following tables, and it has been our endeavor so to arrange them that data referring to cores and shells of like order may be easily compared.

Table 1 contains the constants of the cylinders in the soft state, in which they reached our hands.  $M$  is the weight in grammes for the length  $l$  and diameter  $2\rho$  of cylinder. The latter dimension was determinable with some accuracy by means of a small spherometer. Using this datum and the known density we calculated  $l$ . In case of cylinders as thick as these, it is not easy to obtain accurate mean values for  $l$  by mere measurement. But the difference between observed and calculated  $l$  in the tables is almost wholly due to the differences in the factors of the two centimeter scales (spherometer screw and rule) employed.  $\Delta_t$  is the observed density at  $t^\circ$ . From this we computed  $\Delta$ , the density at  $0^\circ$ , and  $\nabla$ , the corresponding value for specific volume (volume of the unit of mass), by accepting 0.000036 as the coefficient of cubical expansion of steel.

TABLE 1.—Data for the commercial (soft) state.

No.	M	$l$ observed.	$l$ calculated.	$2\rho$ observed.	$t$	$\Delta_t$	$\Delta$	Mean $\Delta$	$\nabla$
	g.	cm.	cm.	cm.	$^\circ C.$				
1	332.4745	5.96	6.013	3.0006	24.6	7.8268	7.8337	7.8337	0.127654
2	332.4955	5.98	6.024	2.9953	24.0	7.8270	7.8337	7.8337	0.127654
3	149.8985	5.97	6.006	2.0139	24.0	7.8296	7.8363	7.8363	0.127612
4	149.9675	5.97	6.024	2.0118	23.8	7.8304	7.8371	7.8371	0.127598
5	37.6219	6.00	6.026	1.0085	24.0	7.8270	7.8338	7.8350	0.127633
5	37.6217				26.8	7.8287	7.8362		

<sup>1</sup> We are indebted to Prof. F. A. Gooch for advice in much of this work.

Tables 2 and 3 contain the first series of results. As above,  $M$ ,  $\rho$ ,  $t$ ,  $\Delta$ ,  $\varphi$  are the symbols of mass, radius, temperature, density, specific volume, respectively, of the cores. Again,  $k$ ,  $\mathcal{S}$ ,  $\mu$ ,  $\delta$  are, respectively, the symbols of mean radius, thickness, mass, density of the elementary shells. If we denote the number of the shell by a subscript, and if the first core be the volume of cylinder left *after* removing the first shell, then the relations between the quantities in the tables are succinctly these:

$$\begin{aligned} \varphi_n &= 1 \mid \Delta_n & R_n &= \frac{1}{2}(\rho_{n-1} + \rho_n) \\ \mathcal{S} &= \rho_{n-1} - \rho_n & \mu_n &= M_{n-1} - M_n \\ \delta_n &= \Delta_{n-1} + \frac{\rho_n}{2\mathcal{S}_n} (\Delta_{n-1} - \Delta_n) \dots \dots \dots \text{(observed)} \\ \delta_n &= \frac{\mu_n}{M_{n-1}\varphi_{n-1} - M_n\varphi_n} \dots \dots \dots \text{(calculated)} \end{aligned}$$

This distinction between observed and calculated is not quite rigid, because both data involve  $\Delta$ , but the other quantities are different.

Tables 4 and 5 contain the second series of results, and are constructed on the same plan as Tables 2 and 3. Little further explanation is therefore required. When observations of  $\Delta$  were made on different days, the date of each is usually given. We may remark that in these and the preceding tables "diameter observed" is usually the mean of ten measurements made with a screw micrometer caliper. In the case of rough surfaces, where frequent repetitions are essential, this instrument is preferable to the spherometer. Except where otherwise stated, the surface has been turned smooth by the diamond.

To facilitate comparison Tables 2 and 3 are printed in parallel form (pp. 18-23), as are also Tables 4 and 5 (pp. 24-27).



TABLE 2.—Cylinders in the glass-hard state. Constants of the consecutive cores. First series of measurements.

[ $l = 6$  cm. approximately.] $M_0, \rho_0, \Delta_0, \nu_0.$ 

No.	M	$\rho$ observed.	$\rho$ calculated.	$t$	$\Delta_t$	$\Delta$	Mean $\Delta$	$\nu$	Remarks.
1	332.1020	1.5041	1.5054	21.3	7.7680	7.7738	7.7744	0.128627	
				24.2	7.7684	7.7750			
3	149.7442	1.0112	1.0123	22.7	7.7457	7.7521	7.7520	0.128996	
				24.0	7.7454	7.7520			
5	37.5913	0.5081	.....	22.4	7.7381	7.7442	7.7442	0.129129	
				18.2	7.7393	7.7443			

 $M_1, \rho_1, \Delta_1, \nu_1.$ 

1	821.9377	1.4832	1.4823	23.1	7.7671	7.7735	7.7734	0.128644	
				26.2	7.7663	7.7734			
8	146.4123	0.9996	1.0012	23.9	7.7419	7.7485	7.7485	0.129057	
				25.2	7.7417	7.7486			

 $M_2, \rho_2, \Delta_2, \nu_2.$ 

1	307.0620	1.4500	1.4477	21.9	7.7667	7.7728	7.7727	0.128655	
				21.9	7.7665	7.7726			
8	132.5652	0.9532	0.9528	21.8	7.7411	7.7472	7.7469	0.129084	
				21.8	7.7403	7.7464			

 $M_3, \rho_3, \Delta_3, \nu_3.$ 

1	292.3284	1.4164	1.4124	21.6	7.7685	7.7746	7.7742	0.128631	
				22.9	7.7673	7.7737			
3	119.1982	0.9051	0.9036	22.0	7.7384	7.7445	7.7453	0.129111	
				22.6	7.7396	7.7460			

 $M_4, \rho_4, \Delta_4, \nu_4.$ 

1	280.3889	1.3895	1.3833	21.1	7.7677	7.7735	7.7734	0.128644	
				22.2	7.7671	7.7732			
3	107.1745	0.8636	0.8566	21.4	7.7417	7.7476	7.7479	0.129067	
				22.0	7.7421	7.7482			

 $M_5, \rho_5, \Delta_5, \nu_5.$ 

1	269.8968	.....	1.3571	22.0	7.7687	7.7748	7.7750	0.128617	
				22.1	7.7690	7.7751			
3	91.0238	.....	0.7894	21.8	7.7421	7.7482	7.7486	0.129056	
				22.0	7.7430	7.7491			

TABLE 3.—Cylinders in the glass-hard state. Constants of the consecutive elementary shells.  
First series of measurements.[ $l = 6$  cm. approximately.] $R_0, \vartheta_0, \mu_0, \delta_0.$ 

No.	$R$ observed.	$R$ calculated.	$\vartheta$ observed.	$\vartheta$ calculated.	$\mu$	$\delta$ observed.	$\delta$ calculated.	Remarks.
1	.....	.....	.....	.....	.....	.....	.....	} Longitudinal crack apparent in the mantle of the cylinder.
3	.....	.....	.....	.....	.....	.....	.....	
5	.....	.....	.....	.....	.....	.....	.....	

First shell.  $R_1, \vartheta_1, \mu_1, \delta_1.$ 

1	1.4930	1.4939	0.0209	0.0231	10.1643	7.809	7.806	Shell flable; removed with hard-steel master tools.
3	1.0004	1.0068	0.0116	0.0111	3.3319	7.904	7.914	

Second shell.  $R_2, \vartheta_2, \mu_2, \delta_2.$ 

1	1.4666	1.4650	0.0332	0.0346	14.8757	7.775	7.792	Shell not flable; dissolved off galvanically. Trued with diamond; shell very hard.
3	0.9764	0.9770	0.0465	0.0484	13.8471	7.705	7.762	

Third shell.  $R_3, \vartheta_3, \mu_3, \delta_3.$ 

1	1.4332	1.4301	0.0336	0.0353	14.7336	7.741	7.738	Vertical and transverse cracks or crevices visible.
3	0.9291	0.9282	0.0481	0.0492	13.3670	7.762	7.762	

Fourth shell.  $R_4, \vartheta_4, \mu_4, \delta_4.$ 

1	1.4030	1.3978	0.0269	0.0291	11.9395	7.795	7.794	Surface shows scaly fracture.
3	0.8858	0.8801	0.0415	0.0470	12.0237	7.718	7.723	

Fifth shell.  $R_5, \vartheta_5, \mu_5, \delta_5.$ 

1	.....	1.3702	0.027	0.0262	10.4921	.....	7.733	
3	.....	0.8230	0.068	0.0672	16.1507	.....	7.744	

TABLE 2:—Cylinders in the glass-hard state. Constants of the consecutive cores. First series of measurements—Continued.

 $M_6, \rho_6, \Delta_6, \nabla_6.$ 

No.	M	$\rho$ observed.	$\rho$ calculated.	t	$\Delta_t$	$\Delta$	Mean $\Delta$	$\nabla$	Remarks.
1	246.7900	1.3026	1.2974	19.5	7.7732	7.7785	7.7784	0.128561*	
				20.8	7.7724	7.7782			
3	71.6405	0.7068	0.7002	19.0	7.7472	7.7425	7.7532	0.128979	
				21.4	7.7481	7.7490			

 $M_7, \rho_7, \Delta_7, \nabla_7.$ 

1	225.8279	1.2556	1.2408	19.5	7.7756	7.7812	7.7813	0.128513	
				20.8	7.7756	7.7814			
3	56.7829	0.6312	0.6232	20.0	7.7507	7.7563	7.7566	0.128923	
				21.2	7.7517	7.7568			

 $M_8, \rho_8, \Delta_8, \nabla_8.$ 

1	211.2518	1.2038	1.2001	18.8	7.7767	7.7820	7.7817	0.128507	
				19.8	7.7758	7.7814			
3	43.2270	0.5989	0.5438	19.2	7.7478	7.7531	7.7538	0.128969	
				22.0	7.7475	7.7536			

 $M_9, \rho_9, \Delta_9, \nabla_9.$ 

1	199.6350	1.1759	1.1664	21.6	7.7780	7.7841	7.7841	0.128467	
				22.0	7.7780	7.7841			
3	36.1996	0.5036	0.4975	22.0	7.7532	7.7593	7.7595	0.128874	
				22.5	7.7536	7.7598			

 $M_{10}, \rho_{10}, \Delta_{10}, \nabla_{10}.$ 

1	163.2372	1.1253	1.1175	21.8	7.7805	7.7866	7.7869	0.128421	
				21.9	7.7811	7.7872			
3	29.7464	0.4603	0.4508	21.9	7.7561	7.7622	7.7637	0.128804	
				21.5	7.7591	7.7652			

 $M_{11}, \rho_{11}, \Delta_{11}, \nabla_{11}.$ 

1	166.7330	1.0725	1.0656	21.4	7.7834	7.7893	7.7894	0.128330	
				21.2	7.7837	7.7895			
3	25.0084	0.4182	0.4134	21.5	7.7558	7.7618	7.7621	0.128831	
				21.0	7.7566	7.7624			

 $M_{12}, \rho_{12}, \Delta_{12}, \nabla_{12}.$ 

1	149.7915	1.0269	1.0099	19.2	7.7866	7.7919	7.7919	0.128338	
				17.4	7.7598	7.7646			
3	20.4688	0.3771	0.3734	17.4	7.7598	7.7646	7.7655	0.128773	
				19.0	7.7613	7.7666			

TABLE 3.—Cylinders in the glass-hard state. Constants of the consecutive elementary shells.  
First series of measurements—Continued.Sixth shell.  $R_6, \vartheta_6, \mu_6, \delta_6$ .

No.	$R$ observed.	$R$ calculated.	$\vartheta$ observed.	$\vartheta$ calculated.	$\mu$	$\delta$ observed.	$\delta$ calculated.	Remarks.
1	1.3298	1.3272	0.0545	0.0597	23.1059	7.734	7.741	
3	0.7481	0.7448	0.0826	0.0892	19.3833	7.729	7.732	

Seventh shell.  $R_7, \vartheta_7, \mu_7, \delta_7$ .

No.	$R$ observed.	$R$ calculated.	$\vartheta$ observed.	$\vartheta$ calculated.	$\mu$	$\delta$ observed.	$\delta$ calculated.	Remarks.
1	1.2791	1.2691	0.0470	0.0566	20.9630	7.740	7.747	
3	0.6690	0.6617	0.0750	0.0770	14.8576	7.739	7.740	Curiously glossy after solution; crack still perceptible.

Eighth shell.  $R_8, \vartheta_8, \mu_8, \delta_8$ .

No.	$R$ observed.	$R$ calculated.	$\vartheta$ observed.	$\vartheta$ calculated.	$\mu$	$\delta$ observed.	$\delta$ calculated.	Remarks.
1	1.2295	1.2204	0.0522	0.0407	14.5761	7.777	7.775	
3	0.5901	0.5835	0.0823	0.0794	13.5550	7.767	7.765	

Ninth shell.  $R_9, \vartheta_9, \mu_9, \delta_9$ .

No.	$R$ observed.	$R$ calculated.	$\vartheta$ observed.	$\vartheta$ calculated.	$\mu$	$\delta$ observed.	$\delta$ calculated.	Remarks.
1	1.1896	1.1832	0.0275	0.0337	11.6168	7.730	7.741	
3	0.5263	0.5206	0.0453	0.0463	7.0274	7.722	7.725	

Tenth shell.  $R_{10}, \vartheta_{10}, \mu_{10}, \delta_{10}$ .

No.	$R$ observed.	$R$ calculated.	$\vartheta$ observed.	$\vartheta$ calculated.	$\mu$	$\delta$ observed.	$\delta$ calculated.	Remarks.
1	1.1507	1.1420	0.0506	0.0489	16.3978	7.753	7.751	
3	0.4818	0.4742	0.0433	0.0467	6.4532	7.737	7.740	

Eleventh shell.  $R_{11}, \vartheta_{11}, \mu_{11}, \delta_{11}$ .

No.	$R$ observed.	$R$ calculated.	$\vartheta$ observed.	$\vartheta$ calculated.	$\mu$	$\delta$ observed.	$\delta$ calculated.	Remarks.
1	1.0989	1.0915	0.0528	0.0519	16.5042	7.758	7.762	
3	0.4393	0.4321	0.0421	0.0374	4.7380	7.772	7.772	

Twelfth shell.  $R_{12}, \vartheta_{12}, \mu_{12}, \delta_{12}$ .

No.	$R$ observed.	$R$ calculated.	$\vartheta$ observed.	$\vartheta$ calculated.	$\mu$	$\delta$ observed.	$\delta$ calculated.	Remarks.
1	*1.0497	†1.0377	*0.0450	†0.0557	16.9415	7.761	7.768	*Rough. †Smooth.
3	*0.3976	†0.3934	*0.0410	†0.0400	4.5999	7.746	7.747	

TABLE 2.—Cylinders in the glass-hard state. Constants of the consecutive cores. First series of measurements—Continued.

 $M_{13}, \rho_{13}, \Delta_{13}, \nabla_{13}$ .

No.	M	$\rho$ observed.	$\rho$ calculated.	$t$	$\Delta_t$	$\Delta$	Mean $\Delta$	$\Delta$	Remarks.
1	138.8822	0.9792	0.9714	18.7	7.7837	7.7890	7.7911	0.128352	
	138.2607	.....	.....	21.9	7.7872	7.7933			
3	.....	0.3354	.....	.....	.....	.....	.....	.....	.....
	.....	.....	.....	.....	.....	.....	.....	.....	.....

 $M_{14}, \rho_{14}, \Delta_{14}, \nabla_{14}$ .

1	127.5671	0.9417	0.9319	21.6	7.7878	7.7939	7.7937	0.128308	
	127.5652	.....	.....	23.1	7.7872	7.7936			
3	.....	0.2850	.....	.....	.....	.....	.....	.....	.....
	.....	.....	.....	.....	.....	.....	.....	.....	.....

 $M_{15}, \rho_{15}, \Delta_{15}, \nabla_{15}$ .

1	117.4393	0.9023	0.8939	22.2	7.7914	7.7975	7.7979	0.128239	
	117.4414	.....	.....	20.0	7.7927	7.7983			
.....	.....	.....	.....	.....	.....	.....	.....	.....	.....

 $M_{16}, \rho_{16}, \Delta_{16}, \nabla_{16}$ .

1	106.8649	0.8651	0.8526	19.8	7.7954	7.8010	7.7999	0.128207	
	106.8635	.....	.....	21.1	7.7942	7.7988			
.....	.....	.....	.....	.....	.....	.....	.....	.....	.....

 $M_{17}, \rho_{17}, \Delta_{17}, \nabla_{17}$ .

1	97.9382	0.8251	0.8161	19.8	7.7961	7.8017	7.8017	0.128177	
	97.9374	.....	.....	21.2	7.7952	7.8010			
.....	.....	.....	.....	.....	.....	.....	.....	.....	.....

 $M_{18}, \rho_{18}, \Delta_{18}, \nabla_{18}$ .

1	86.1936	0.7767	0.7656	20.5	7.7961	7.8017	7.8013	0.128184	Equatorial parts just flable.
	86.1931	.....	.....	22.2	7.7947	7.8008			
.....	.....	.....	.....	.....	.....	.....	.....	.....	.....

 $M_{19}, \rho_{19}, \Delta_{19}, \nabla_{19}$ .

1	74.8681	0.7238	0.7135	21.5	7.7973	7.8031	7.8027	0.128161	Fileable.
	74.8673	.....	.....	23.0	7.7960	7.8024			
.....	.....	.....	.....	.....	.....	.....	.....	.....	.....

 $M_{20}, \rho_{20}, \Delta_{20}, \nabla_{20}$ .

1	61.4094	0.6515	0.6462	19.4	7.7973	7.8026	7.8009	0.128190	Fileable.
	61.4078	.....	.....	22.2	7.7931	7.7992			
.....	.....	.....	.....	.....	.....	.....	.....	.....	.....

TABLE 3.—Cylinders in the glass-hard state. Constants of the consecutive elementary shells.  
First series of measurements—Continued.

Thirteenth shell.  $R_{13}, \vartheta_{13}, \mu_{13}, \delta_{13}$ .

No.	$R$ observed.	$R$ calculated.	$\vartheta$ observed.	$\vartheta$ calculated.	$\mu$	$\delta$ observed.	$\delta$ calculated.	Remarks.
1	*1.0031	†0.9907	*0.0477	†0.0385	11.2200	7.800	7.800	* Rough. † Smooth.
3	0.3563	.....	0.0417	.....	.....	.....	.....	

Fourteenth shell.  $R_{14}, \vartheta_{14}, \mu_{14}, \delta_{14}$ .

1	0.9605	0.9516	0.0375	0.0395	11.0054	7.762	7.758	
3	0.3102	.....	.....	.....	.....	.....	.....	No. 3 broken.

Fifteenth shell.  $R_{15}, \vartheta_{15}, \mu_{15}, \delta_{15}$ .

1	0.9220	0.9129	0.0394	0.0380	10.1258	7.746	7.745	
---	--------	--------	--------	--------	---------	-------	-------	--

Sixteenth shell.  $R_{16}, \vartheta_{16}, \mu_{16}, \delta_{16}$ .

1	0.8837	0.8733	0.0372	0.0413	10.5701	7.775	7.778	
---	--------	--------	--------	--------	---------	-------	-------	--

Seventeenth shell.  $R_{17}, \vartheta_{17}, \mu_{17}, \delta_{17}$ .

1	0.8451	0.8343	0.0399	0.0365	8.9204	7.781	7.780	
---	--------	--------	--------	--------	--------	-------	-------	--

Eighteenth shell.  $R_{18}, \vartheta_{18}, \mu_{18}, \delta_{18}$ .

1	0.8009	0.7908	0.0485	0.0505	11.7445	7.805	7.805	Equatorial parts flake.
---	--------	--------	--------	--------	---------	-------	-------	-------------------------

Nineteenth shell.  $R_{19}, \vartheta_{19}, \mu_{19}, \delta_{19}$ .

1	0.7502	0.7395	0.0529	0.0521	11.3256	7.792	7.793	
---	--------	--------	--------	--------	---------	-------	-------	--

Twentieth shell.  $R_{20}, \vartheta_{20}, \mu_{20}, \delta_{20}$ .

1	0.6870	0.6799	0.0723	0.0673	13.4591	7.811	7.810	
---	--------	--------	--------	--------	---------	-------	-------	--

TABLE 4.—Cylinders in the glass-hard state. Constants of the consecutive corcs. Second series of measurements.

[l=6 cm. approximately.]

$M_0, \rho_0, \Delta_0, \nabla_0.$

No.	M	$\rho$ observed.	$\rho$ calculated.	t	$\Delta_t$	$\Delta$	Mean $\Delta$	$\nabla$	Remarks.
2	332.2677	1.5010	1.5043	22.2	7.7841	7.7902	7.7900	0.128370	
	.....	.....	.....	22.2	7.7837	7.7898	.....		
4	149.8939	1.0133	1.0114	22.0	7.7678	7.7739	7.7740	0.128634	
	.....	.....	.....	17.8	7.7690	7.7740	.....		
6	115.3561	0.8919	0.8855	22.2	7.7975	7.8036	7.8039	0.128141	
	.....	.....	.....	17.9	7.7992	7.8042	.....		

$M_1, \rho_1, \Delta_1, \nabla_1.$

2	321.1428	1.4785	1.4785	23.9	7.7798	7.7864	7.7878	0.128406	Rough. Oct. 29, 1885.
	320.6413	.....	.....	19.4	7.7839	7.7892	.....	.....	Smooth. Oct. 31, 1885.
$\alpha 4$	144.7017	0.9970	0.9938	23.8	7.7661	7.7727	7.7733	0.128645	Oct. 29, 1885.
	144.7017	.....	.....	19.8	7.7682	7.7738	.....	.....	Oct. 31, 1885.
$\alpha 6$	108.1191	0.8653	0.8575	23.6	7.7934	7.8000	7.8011	0.128187	Oct. 29, 1885.
	108.1191	.....	.....	19.8	7.7966	7.8022	.....	.....	Oct. 31, 1885.

$\alpha$  Difference in  $\Delta$  possibly the result of shrinkage.

$M_2, \rho_2, \Delta_2, \nabla_2.$

2	310.9500	1.4558	1.4549	20.3	7.7832	7.7888	7.7894	0.128380	Rough.
	310.6535	.....	.....	21.2	7.7842	7.7900	.....	.....	Smooth.
4	136.9445	0.9688	0.9663	19.4	7.7681	7.7734	7.7743	0.128629	Rough.
	136.7036	.....	.....	19.6	7.7697	7.7753	.....	.....	Smooth.
6	100.5121	0.8314	0.8260	20.0	7.7924	7.7980	7.7997	0.128210	Rough.
	100.1245	.....	.....	20.1	7.7959	7.8015	.....	.....	Smooth.

$M_3, \rho_3, \Delta_3, \nabla_3.$

2	297.6610	1.4260	1.4237	22.2	7.7849	7.7910	7.7912	0.128350	
	297.6550	.....	.....	22.3	7.7853	7.7914	.....	.....	
4	126.3200	0.9327	0.9284	22.0	7.7600	7.7751	7.7750	0.128617	
	126.3191	.....	.....	23.4	7.7685	7.7749	.....	.....	
6	89.6386	0.7876	0.7809	21.2	7.7929	7.7987	7.7985	0.128230	
	89.6377	.....	.....	23.7	7.7920	7.7984	.....	.....	

$M_4, \rho_4, \Delta_4, \nabla_4.$

2	285.8320	1.4001	1.3950	22.0	7.7865	7.7926	7.7923	0.128332	
	285.8302	.....	.....	21.1	7.7862	7.7920	.....	.....	
4	116.3412	0.9024	0.8908	22.4	7.7706	7.7767	7.7773	0.128579	
	116.3427	.....	.....	20.4	7.7721	7.7779	.....	.....	
6	79.2544	0.7436	0.7342	20.6	7.7940	7.7998	7.7990	0.128222	
	79.2530	.....	.....	22.6	7.7919	7.7983	.....	.....	

TABLE 5.—Cylinders in the glass-hard state. Constants of the consecutive elementary shells. Second series of measurements.

[l=6 cm. approximately.]

 $R_0, \vartheta_0, \mu_0, \delta_0.$ 

No.	$R$ observed.	$R$ calculated.	$\vartheta$ observed.	$\vartheta$ calculated.	$\mu$	$\delta$ observed.	$\delta$ calculated.	Remarks.
2	.....	.....	.....	.....	.....	.....	.....	
4	.....	.....	.....	.....	.....	.....	.....	
6	.....	.....	.....	.....	.....	.....	.....	

First shell.  $R_1, \vartheta_1, \mu_1, \delta_1.$ 

2	1.4897	1.4914	0.0225	0.0258	11.3757	7.862	7.847	
4	1.0051	1.0026	0.0164	0.0176	5.1922	7.795	7.795	
6	0.8786	0.8615	0.0266	0.0280	7.2370	7.849	7.847	

Second shell.  $R_2, \vartheta_2, \mu_2, \delta_2.$ 

2	1.4676	1.4667	0.0226	0.0236	10.0903	7.736	7.746	
4	0.9829	0.9800	0.0282	0.0275	7.8777	7.756	7.756	
6	0.8483	0.8417	0.0339	0.0315	15.0378	7.818	7.832	

Third shell.  $R_3, \vartheta_3, \mu_3, \delta_3.$ 

2	1.4410	1.4393	0.0298	0.0312	13.1437	7.746	7.748	
4	0.9598	0.9473	0.0362	0.0379	10.5044	7.765	7.766	
6	0.8095	0.8035	0.0437	0.0451	10.6801	7.810	7.810	

Fourth shell.  $R_4, \vartheta_4, \mu_4, \delta_4.$ 

2	1.4130	1.4093	0.0259	0.0287	11.8224	7.762	7.765	
4	0.9175	0.9096	0.0303	0.0376	9.9776	7.741	7.748	
6	0.7656	0.7575	0.0440	0.0467	10.3845	7.794	7.794	



TABLE 4.—Cylinders in the glass-hard state. Constants of the consecutive cores. Second series of measurements—Continued.

 $M_5, \rho_5, \Delta_5, \nabla_5.$ 

No.	M	$\rho$ observed.	$\rho$ calculated.	$t$	$\Delta_t$	$\Delta'$	Mean $\Delta$	$\Delta$	Remarks.
2	270.2447	1.3635	1.3562	20.6	7.7899	7.7957	7.7953	0.128282	
	270.2450	.....	.....	22.0	7.7888	7.7949	.....	.....	
4	105.6781	0.8580	0.8489	20.1	7.7749	7.7805	7.7803	0.128529	
	105.6777	.....	.....	21.5	7.7741	7.7802	.....	.....	
6	69.1823	0.6888	0.6862	21.6	7.7898	7.7959	7.7956	0.128277	
	69.1831	.....	.....	20.3	7.7897	7.7953	.....	.....	

 $M_6, \rho_6, \Delta_6, \nabla_6.$ 

2	255.7194	1.3244	1.3190	22.7	7.7910	7.7974	7.7973	0.128249	
	255.7207	.....	.....	20.8	7.7915	7.7973	.....	.....	
4	96.7900	0.8205	0.8122	21.5	7.7761	7.7822	7.7833	0.128480	
	96.7908	.....	.....	20.0	7.7789	7.7842	.....	.....	
6	60.3109	0.6492	0.6406	20.4	7.7913	7.7969	7.7963	0.128266	
	60.3108	.....	.....	21.7	7.7897	7.7958	.....	.....	

 $M_7, \rho_7, \Delta_7, \nabla_7.$ 

2	244.6228	1.2962	1.2900	21.8	7.7928	7.7989	7.7990	0.128221	
	244.6207	.....	.....	23.2	7.7928	7.7992	.....	.....	
4	88.4158	0.7851	0.7762	21.0	7.7796	7.7854	7.7850	0.128452	
	88.4148	.....	.....	22.5	7.7783	7.7847	.....	.....	
6	52.0593	0.6062	0.5953	21.4	7.7863	7.7921	7.7928	0.128323	
	52.0498	.....	.....	22.6	7.7872	7.7936	.....	.....	

 $M_8, \rho_8, \Delta_8, \nabla_8.$ 

2	226.9512	1.2512	1.2422	22.5	7.7958	7.8022	7.8022	0.128169	
	226.9500	.....	.....	24.4	7.7956	7.8022	.....	.....	
4	76.7934	0.7269	0.7241	21.7	7.7830	7.7891	7.7883	0.128397	
	76.7932	.....	.....	23.2	7.7812	7.7876	.....	.....	
6	42.5669	0.5486	0.5383	22.0	7.7882	7.7943	7.7935	0.128312	
	42.5664	.....	.....	23.4	7.7862	7.7926	.....	.....	

 $M_9, \rho_9, \Delta_9, \nabla_9.$ 

2	205.7577	1.1946	1.1825	21.2	7.8009	7.8067	7.8064	0.128100	
	205.7554	.....	.....	23.0	7.7997	7.8061	.....	.....	
4	63.6639	0.6635	0.6584	19.7	7.7866	7.7922	7.7915	0.128345	
	63.6630	.....	.....	22.5	7.7846	7.7909	.....	.....	
6	31.9783	0.4729	0.4607	22.6	7.7814	7.7877	7.7875	0.128411	
	31.9793	.....	.....	20.0	7.7816	7.7872	.....	.....	

TABLE 5.—Cylinders in the glass-hard state. Constants of the consecutive elementary shells. Second series of measurements—Continued.

Fifth shell.  $R_5, \vartheta_5, \mu_5, \delta_5$ .

No.	$R$ observed.	$R$ calculated.	$\vartheta$ observed.	$\vartheta$ calculated.	$\mu$	$\delta$ observed.	$\delta$ calculated.	Remarks.
2	1.3817	1.3756	0.0366	0.0388	15.5908	7.737	7.741	
4	0.8802	0.8698	0.0444	0.0419	10.6641	7.748	7.748	
6	0.7162	0.7102	0.0548	0.0480	10.0710	7.820	7.823	

Sixth shell.  $R_6, \vartheta_6, \mu_6, \delta_6$ .

2	1.3439	1.3376	0.0391	0.0372	14.5248	7.761	7.760	
4	0.8393	0.8305	0.0375	0.0367	18.8875	7.747	7.747	
6	0.6690	0.6634	0.0397	0.0456	8.8719	7.795	7.791	

Seventh shell.  $R_7, \vartheta_7, \mu_7, \delta_7$ .

2	1.3103	1.3045	0.0283	0.0290	11.0983	7.758	7.756	
4	0.8028	0.7942	0.0355	0.0360	8.3754	7.765	7.768	
6	0.6276	0.6180	0.0430	0.0453	8.2608	7.821	7.819	

Eighth shell.  $R_8, \vartheta_8, \mu_8, \delta_8$ .

2	1.2661	1.2661	0.0498	0.0478	17.6711	7.759	7.760	
4	0.7561	0.7501	0.0582	0.0521	11.6217	7.764	7.763	
6	0.5774	0.5668	0.0575	0.0570	9.4833	7.790	7.790	

Ninth shell.  $R_9, \vartheta_9, \mu_9, \delta_9$ .

2	1.2228	1.2123	0.0566	0.0597	21.1941	7.758	7.762	
4	0.6953	0.6912	0.0635	0.0657	13.1298	7.772	7.773	
6	0.5108	0.5025	0.0758	0.0716	10.5879	7.812	7.812	

*Resistance data.*—The present results for specific resistance are merely preliminary. They show, however, that even in the case of steel rods one centimeter in diameter and of but a few hundred microhms total resistance, the electrical method may be successfully applied to the study of structural phenomena and made to yield good results. The reasons for this are at hand. The resistance effect due to changes of temper is enormously large as compared with the density effect. The interval hard soft, when referred to the electrical scale, comprehends 300 per cent. of the resistance of soft steel; whereas the density effect is certainly smaller than 3 per cent. of the density of soft steel. The extreme sensitiveness of the resistance method is to some degree vitiated, however, by the fact that the electrical constants involve the dimensions of the rods; and very frequently right sections are not determinable within a few per cent. Moreover, in case of resistances as small as those mentioned, the electrical measurement itself must be made with caution, and the error will under all circumstances amount to 1 or 2 per cent. None of these difficulties enter into a determination of the density effect; but in spite of the objections specified, the large range of electrical variation renders the resistance method certainly as accurate as the density method. It will be invaluable for the investigation of slow changes of strain; such, for instance, as would result if the stress in the interior parts were essentially conditioned by the stress at the exterior or superficial parts of a tempered steel rod (see Shrinkage, p. 41). In this case the necessary results depend on purely electrical data only. The two methods are admirably complementary, for the resistance method begins to yield satisfactorily reliable data at the very stage of thickness of rod where the density method shows insufficient sensitiveness, and conversely.

The resistance method has a further advantage: the errors due to hard ends (see p. 31) may be wholly and conveniently eliminated. For if these comparatively thin rods be inserted in the dissolving cell already described, it is only necessary to slide a piece of rubber hose over the ends to confine the solution to as small a part of the equatorial regions of the rod as may be desired. Moreover, thickness may be reduced with some uniformity throughout the chosen lengths, even as far as 0.1<sup>cm</sup> of diameter. In the annexed diagram (Fig. 5) one of these rods,

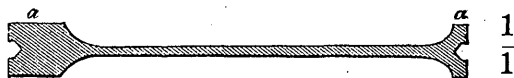

FIG. 5. Rod No. 11, after removal of seven shells.

from which seven successive layers have been removed, is drawn full size. During solution the parts *a a* are covered with rubber, as has been stated.

To hold the rods during the resistance measurement, we devised the

special form of clamp shown in the annexed diagram (Fig. 6). *A A* is a block of oiled wood, through the middle of which passes an iron bolt *cd*, carrying a steel cross-piece, *ef*, both ends of which are conical. Attached to the ends of the block *A A* are two thick strips of hard rubber or of metal, *ab ab*, carrying steel screws, *mn mn*, the points, *n n* of which are also conical. The rods *ne fn* are tested in pairs, and secured by aid of conical depressions in their end surfaces, between the sharp ends of the screws *mn mn* and the ends of the cross-piece *ef*, as shown in the figure. At *m m* copper terminals have been soldered into the heads of the steel screws, through which the line of metal *mn ef nm* is inserted with a standard into one branch of the bridge, the other being the calibrated wire. From four brass clamps, *r r r r*, copper wires pass tensely around the respective steel rods *ne fn*, and thence (alternately) through galvanometer to sliding contact. The method of measurement is that of Matthiessen-Hockin.

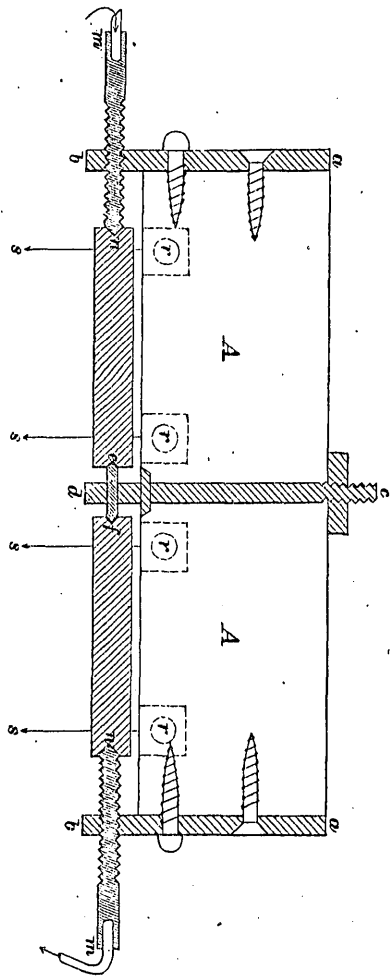

FIG. 6. Holder for resistance measurements.

The experimental data obtained in the way described are given in Tables 6 to 8. In Table 6 (Rod No. 3), column one contains the number of the core from which the resistance  $W_t$ , at  $t^\circ$ , for the effective length,  $l$ , and the radius  $\rho$  are derived. The column  $S_0$  gives the corresponding specific resistance, at  $0^\circ$ , for the rod in a condition of either rough or smooth surface (trued with diamond), as specified.

TABLE 6.—Resistance constants (No. 3).

No.	$W_t$	$t$	$l$	$\rho$	$S_0$	
Core 11 .....	333	19	4.95	0.4182	35.7	
Core 12 .....	386	17	4.90	.....	34.3	Rough.
	349	17	4.45	0.3771	33.8	Smooth.
Core 13 .....	484	20	4.92	.....	33.5	Rough.
	461	20	4.52	0.3354	34.7	Smooth.
Core 14 .....	674	27	4.65	0.2850	35.3	Smooth.

The values for  $S_0$  being certainly affected with an error of, say, 3 per cent., must be regarded as coincident. They merely show that after the removal of 14 shells the variations of the hardness of No. 3 occur within narrow limits. Moreover, the absolute value of  $S_0$  is small, indicating either a poor quality of steel, or, more probably, that the strata of large resistance have been removed.

Similar results, but more complete, are given in Table 7. The nomenclature is the same as that used above.  $S_n$ , the specific resistance of consecutive cores at  $t^\circ$ , is reduced to the values for  $0^\circ$ , by aid of the temperature coefficient,  $\alpha$ .  $R$ ,  $\varnothing$ ,  $s$  denote the mean radius, thickness, and specific resistance, respectively, of the shells. We have, therefore,

$$R_n = \frac{1}{2}(\rho_{n-1} + \rho_n) \quad S_n = \rho_{n-1} - \rho_n \quad s_n = \frac{q_n}{Q_{n-1} A_{n-1} - Q_n A_n}$$

when  $Q$  and  $A$  are symbols of section and conductivity, respectively, and  $q_n = Q_{n-1} - Q_n$ .

TABLE 7.—*Stubs's bright steel. Resistance constants of the consecutive cores and shells. Rods tempered glass-hard.*

[1 = 6 cm. approximately.]

No.	Shell.	$W_t$	$\rho$	$t$	$S_t$	$\alpha$	$S_0$	$R$	$\varnothing$	$s$
		<i>Microhm.</i>	<i>Cm.</i>	<i>°C.</i>	<i>Microhm.</i>		<i>Microhm.</i>	<i>Cm.</i>	<i>Cm.</i>	<i>Microhm.</i>
11	0.....	660	0.318	19	42.7	0.0017	41.4	.....	.....	.....
	1.....	820	0.294	20	45.4	16	44.1	0.306	0.0240	31
	2.....	1,000	0.262	22	45.4	16	44.0	0.278	0.0318	46
	3.....	1,290	0.227	18	44.5	17	43.2	0.244	0.0349	45
	4.....	2,250	0.167	20	45.1	16	43.3	0.197	0.0599	43
	5.....	4,130	0.130	21	47.7	15	46.3	0.149	0.0367	39
	6.....	6,620	0.103	21	48.0	15	46.6	0.117	0.0273	46
7.....	{ 16,110 15,970	0.069 0.070	24 22	52.5 56.4	15 14	50.9 54.8	0.086 0.087	0.0338 0.0331	44 41	
12	0.....	680	0.318	19	43.1	0.0017	41.8	.....	.....	.....
	1.....	820	0.296	20	44.0	17	42.6	0.307	0.0215	37
	2.....	1,020	0.262	22	44.2	17	42.7	0.279	0.0337	43
	3.....	1,300	0.235	18	45.5	16	44.3	0.249	0.0270	37
	4.....	2,440	0.182	20	47.3	15	46.0	0.208	0.0538	42
	5.....	3,390	0.148	21	47.0	15	45.7	0.165	0.0337	47
	6.....	5,400	0.114	21	45.8	16	44.4	0.131	0.0336	47
7.....	{ 11,950 9,520	0.089 0.088	24 22	67.1 51.6	15 16	64.9 49.9	0.102 0.101	0.0253 0.0266	*30 38	
8.....	22,640	0.059	23	52.5	16	50.8	0.073	0.0291	49	
13	0.....	660	0.318	19	41.8	0.0017	40.4	.....	.....	.....
	1.....	730	0.304	21	43.4	17	42.0	0.311	0.0140	30
	2.....	800	0.288	20	43.8	17	42.4	0.296	0.0158	38
	3.....	910	0.267	18	44.2	17	43.0	0.278	0.0204	39
	4.....	1,310	0.223	20	45.0	16	43.7	0.245	0.0442	41
	5.....	2,110	0.179	21	45.4	16	44.0	0.201	0.0444	43
	6.....	3,200	0.149	20	47.0	15	45.8	0.164	0.0297	41
7.....	8,330	0.092	23	48.5	15	47.0	0.120	0.0574	45	

TABLE No. 7.—*Stubs's bright steel. Resistance constants of the consecutive cores and shells. Rods tempered glass-hard—Continued.*

No.	Shell.	W	$\rho$	t	S	$\alpha$	$S_0$	R	$\vartheta$	s
		<i>Microhm.</i>	<i>Cm.</i>	<i>°C.</i>	<i>Michrom.</i>		<i>Michrom.</i>	<i>Cm.</i>	<i>Cm.</i>	<i>Michrom.</i>
14	0.....	680	0.318	19	42.6	0.0017	41.4	-----	-----	-----
	1.....	740	0.304	21	43.4	17	42.0	0.311	0.0134	36
	2.....	1,090	0.289	20	56.2	14	54.8	(0.297)	(0.0155)	(a)
	3.....	960	0.269	18	44.0	17	42.7	0.287	0.0350	39
	4.....	1,360	0.227	20	44.8	16	41.9	0.248	0.0422	45
	5.....	1,990	0.189	21	46.3	16	44.9	0.208	0.0382	30
	6.....	2,930	0.158	20	48.4	15	47.0	0.173	0.0309	40
	7.....	5,710	0.106	23	44.5	17	42.9	0.132	0.0517	51
	8.....	21,280	0.062	23	55.5	14	53.9	0.084	0.0444	39

a Bad contact.

Some of the results (see Nos. 11 and 12, shell 7; No. 14, shell 2) which it was found necessary to repeat show how exceedingly important it is to secure excellence of contact throughout the bridge adjustments. In repeating the experiments we should temper rods 20<sup>cm</sup> long, solder the ends to copper terminals, and remove only equatorial parts of shell. We may remark that the sectional error is here probably positive and relatively large for small values of section. This introduces a very serious element of uncertainty into the results. *s* is only to be regarded as a check on  $S_0$ .

Table 8, finally, contains direct tests for shrinkage.  $\rho$  being the radius of the core,  $W_t$  denotes the resistance before and after the lapse of the number of hours given under *h*. If shrinkage is an actual occurrence, it must be a phenomenon of viscosity; and hence the observed effect would vary gradually through infinite time. The differences of  $W_t$ , in Table 8, however, are mere errors of observation.

TABLE 8.—*Resistance tests for shrinkage.*

No.	Date.	h	$\rho$	$W_t$	Remarks.
5	-----	-----	0.318	-----	Original radius.
5	November 19, 1885 .....	0	0.30	1,030	One shell off.
	November 20, 1885 .....	15	-----	1,022	
5	November 20, 1885 .....	0	0.20	1,803	Two shells off.
	November 21, 1885 .....	21	-----	1,803	

DISCUSSION.

*True and apparent structure.*—In Bulletin 14 we defined structure (p. 113, note) as the law of variation of density encountered on a passage along any radius of the rod, from axis to circumference. But a mere glance at the above tables shows that we must obtain greater uniformity of results if we reverse the order of progress and follow variations of

density from the surface normally *inward*. Let depth, taken positive in the direction from surface to axis, be denoted by  $x$ . Then the above tables enable us to construct

$$\delta = F(x) \dots \dots \dots (1)$$

where  $F$  is a symbol of functionality and  $\delta$  the apparent density at a distance  $x$  below the surface.  $\delta$  is an approximate expression for the structure of the rod. To pass from this  $F(x)$  to the true structure, it is necessary to make allowance for the fact that in any given uniformly tempered cylinder the elementary coaxial shells are not homogeneous in the axial direction; that they increase in density as we pass from median plane toward the ends of the cylinder. More succinctly: In view of the relatively small length ( $2l_0$ ) of the cylinders as compared with their diameters ( $2\rho_0$ ), the available method of tempering necessarily imparts to them a box-within-box structure. Hence, it follows that

$$l_0 F(x) = (l_0 - x)f(x) + \int_0^x f(x) dx \dots \dots \dots (2)$$

By differentiating, simplifying, and again integrating, this equation leads to an elegant expression for true structure,  $f(x)$ , in terms of apparent structure,  $\delta$ :

$$f(x) = l_0 \int \frac{F'(x)}{l_0 - x} dx = l_0 \int \frac{\delta'}{l_0 - x} dx \dots \dots \dots (3)$$

$f(x)$  being the density at a point anywhere within the cylinder at the distance  $x$  normally below the surface.

With equation (3) in hand, it is then easy to investigate corresponding expressions for  $\Delta$ , the mean density of successive cores, in terms of  $f(x)$  and  $x$ . These, however, appear under involved forms. They throw no new light on the discussion, and therefore are omitted.

*Density,  $\Delta$ , of successive cores.*—To digest the data in the above tables we shall first examine the relations of  $\Delta$ , the mean density of core; and then from these introductory results proceed with the discussion of structure proper.

In Figure 7 we have constructed the various results of Tables 1, 2, 4, by representing  $\Delta$  as a function of radius. The loci for the data of cylinders Nos. 1, 2, 3, 4, all of which hold for steel of the same kind, are similar in their general character. This becomes very clear if we pass from the surface in the direction of negative  $\rho$  toward the axis. After removing superficial shells,  $\Delta$  appreciably falls in all cases to a pronounced minimum. It then increases at approximately the same rate for each cylinder and in a direction which if indefinitely prolonged would trend toward the diagrammatic position of "soft" (not easily introduced into the figure). The chief features of these curves are therefore the minima, their approximate parallelism, their apparently linear contour, their independence of radius. Having obtained these results we were inclined to look for similar variations in all other kinds of steel.

Not a little startled were we, therefore, by the data for No. 6, which show an almost complete inversion of the structural character of the earlier rods. In the cases of Nos. 1 to 4,  $\Delta$  increases from the circumference inward; in the case of No. 6,  $\Delta$  continually decreases, indeed at

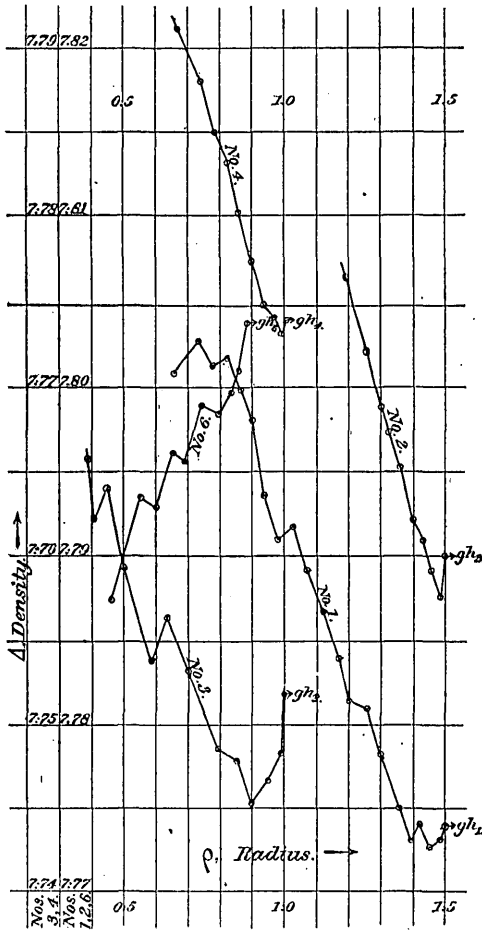

FIG. 7. Density as a function of radius.

almost the same rate. It is therefore clear that structure must be radically conditioned by the *quality* of the steel carrying temper. In other words, to discriminate between different kinds of steel by structure ( $f(x)$ ) data, our classification would show immediate relations to the power for retaining stress heretofore postulated.<sup>1</sup>

The superficial minimum or corresponding point in No. 6, occurring as it does generally, is an observation of some importance. It probably marks the depth of layer below which the combined processes of diffusion and oxidation no longer remove carbon from steel. This depth

<sup>1</sup> U. S. Geol. Surv. Bull. 14, p. 95.



will of course depend on the time of exposure to high temperature before quenching. The observation in question is confirmed by this experimental result: if rods be heated very intensely (Nos. 1 and 3, incipient white heat), the superficial layers are frequently so soft as to yield readily to steel master tools. Moreover in No. 1, which was twice quenched, this shell is comparatively thick. The underlying core is always very hard, and it is thus possible to arrive at the thickness of the soft shell with some accuracy. It does not extend inward as far as the minimum; but this does not tend to invalidate the remarks just made, because softness, after quenching, must correspond to an extreme degree of decarburization. There is, however, one point of view from which the minimum acquires greater significance than a secondary or incidental result. If the rod subjected to sudden cooling be sufficiently thick, it is obvious that the interior will remain soft. Hence the march of  $\Delta$  toward smaller values, exhibited by No. 6, cannot keep on indefinitely.  $\Delta$  must pass through a minimum and then again increase. Hence we infer that the position of this minimum bears some inherent relation to the quality of the steel under observation — that its depth will increase in proportion as the intensity of strain which the rod can carry without rupture, increases. Further experiments are necessary to decide this question.

It is curious to note that the glass-hard  $\Delta$  of longitudinally cracked rods (Nos. 3 and 5) is smaller than that of rods of unbroken surface. This difference may be an expression for the intensity of stress lost in consequence of rupture. More probably it is an effect of thickness.

In the case of No. 1 structure has been studied throughout an interval of almost one centimeter of depth. But it is not until we reach the lowest layers for this depth that the curve manifests any tendency to change its character. And even here the evidence is uncertain, both because the density measurements of the comparatively thin rod are no longer so accurate and because the effect of hard ends, to which we adverted in the preceding paragraph, becomes more and more seriously appreciable as radius decreases. The singularly simple and suggestive curves are therefore in striking contrast with the necessarily complex considerations which must enter into their interpretation. If the cylinder be originally given of length  $2l_0$  and of diameter  $2\rho_0$ , and if then a shell of thickness  $x$  be removed, careful inspection of the core will enable us to distinguish the following three parts: (1) The central cylinder bounded by mantle (radius  $\rho_0 - x$ ) and two normal planes at a distance  $l_0 - \rho_0$  and  $-(l_0 - \rho_0)$  from the equator. Within this partial cylinder  $\delta$  varies from  $f(\rho_0)$  to  $f(x)$  in the direction of radius, symmetrically with respect to axis. (2) The two end cylinders bounded by mantle and by normal planes,  $l_0$  and  $l_0 - x$ ,  $-l_0$ , and  $-(l_0 - x)$ , respectively, from the equator. Here  $\delta$  changes from  $f(x)$  to  $f(0)$  in the direction of axis, symmetrically with respect to equator. (3) The two intermediate

partial cylinders bounded by mantle and normal planes,  $l_0 - \rho_0$  and  $l_0 - x$ , —  $(l_0 - \rho_0)$ , and —  $(l_0 - x)$ . It is here that the variation of  $\delta$  is involved. To represent it approximately in the right partial cylinder, let a cone be described around a given axis, upon the basal plane  $l_0 - x$ , with its vertex at a distance  $l_0 - \rho_0$  from the equator. This cone divides the said partial cylinder into parts such that in the re-entrant figure,  $\delta$  varies from  $f(\rho_0)$  to  $f(x)$  in the direction of radius, symmetrically with respect to axis. In the simple conical figure,  $\delta$  varies from  $f(\rho_0)$  to  $f(x)$  in the direction of axis, symmetrically with respect to equator. In view of these annoying complications, it is expedient to calculate  $\delta$  from successive values of  $\Delta$ . This may be done without any auxiliary hypothesis at all. Having given  $\delta$  we arrive at the true structure as shown in the preceding paragraph.

These remarks show that to obtain perspicuous values for  $\Delta$  it is advisable to use only the equatorial parts for measurement; that is, to remove the ends completely either by solution or by suitable mechanical means before commencing the structure-measurements proper.

*Density,  $\delta$ , of successive shells.*—In our endeavor to construct the relation between the density  $\delta$  (apparent structure) and the mean radius of shell,  $R$ , we must necessarily be guided by the following consideration: If the shell be thin and contain no maximum or other singular point, then the observed  $\delta$  is approximately a point on the locus sought; but if the shell, however thin, contain one or more maxima, then the observed  $\delta$  need not be a point on the locus at all, and the discrepancies and the liability to errors of interpretation will increase as the maxima become more and more sharp and crowded. Let the shell be so thin that its outer and its inner radius are practically identical with its mean radius, i. e., that the right section does not differ appreciably from  $2\pi R \delta R = 2\pi R \mathcal{S}$ , in area. In this case  $2\pi R \mathcal{S} \delta$  is the mean mass per unit of length of shell; and hence any elementary contour which, between  $R - \mathcal{S}/2$  and  $R + \mathcal{S}/2$  incloses the same area as  $\mathcal{S} \delta$ , may be taken as a boundary of the part of the curve under examination. This shows at once the nature of the difficulties encountered in endeavoring to discuss the present observations on structure. It opens a field for speculation so wide as to be thoroughly unsafe. We will, therefore, in the sequel, limit ourselves to right line diagrams, to mere linear combinations of the points given by experiment. We thus exhibit the results, as far as possible, unaffected by any fantasy of our own.

In Fig. 8 the values for  $\delta$  are represented as functions of  $R$ , on a scale in correspondence with the smaller accuracy of the present set of data. The scale is, moreover, such as enables us to insert the interval hard-soft for each curve. Restricting our comparison to Nos. 1 to 4 for the present, we find at first sight that the variations are jagged and apparently irregular and confused. It is, therefore, well to confine the discussion still further; to examine the data holding for No. 1, for which cylinder the observations are most nearly complete; then to use the

other curves as a means of corroborating and of further elucidating the divers inferences drawn.

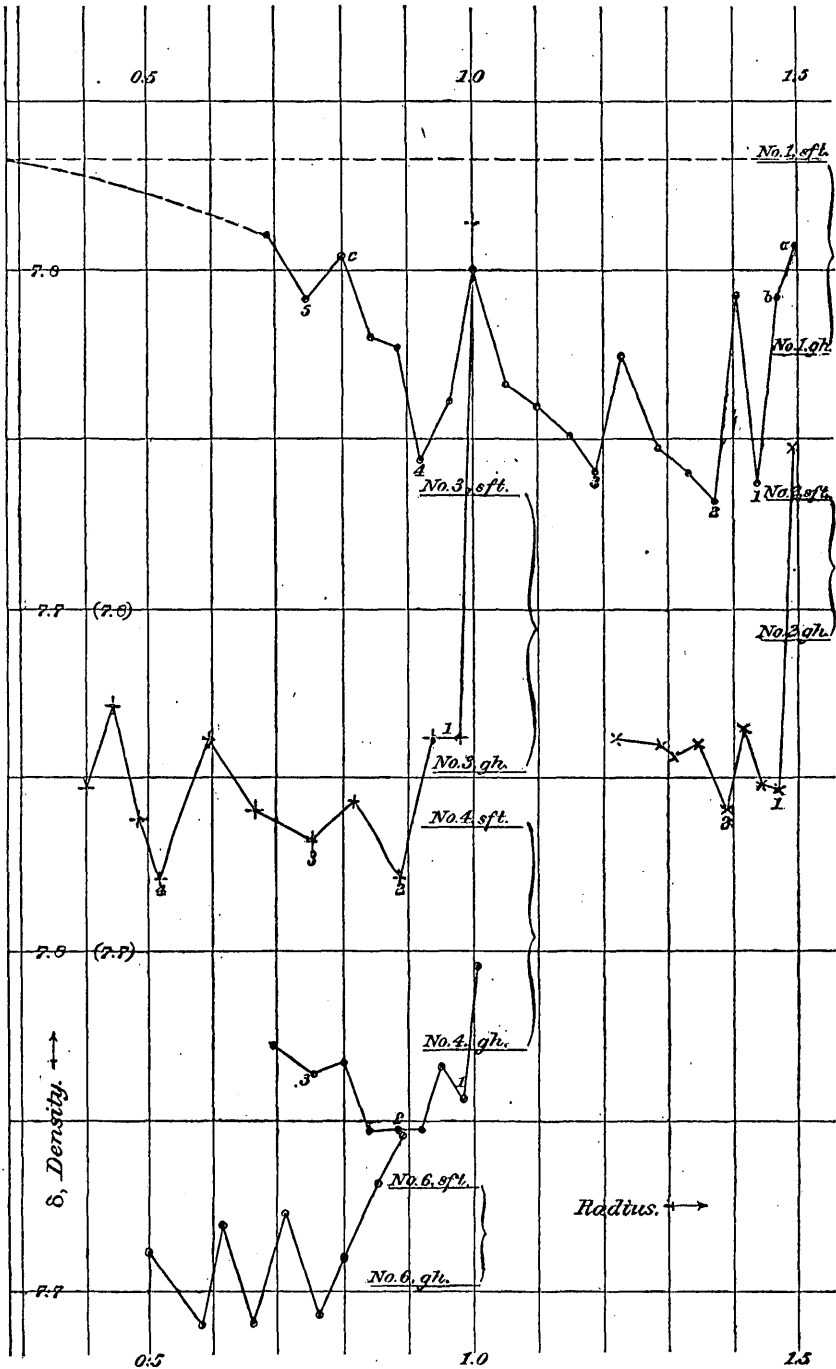

FIG. 8. Elementary density as a function of radius.

Inasmuch as the evidence given by No. 1 is fully valid (see discussion under Errors, p. 43), as we pass from the circumference inward  $\delta$  varies in accordance with an obviously harmonic law. We readily discern five pronounced periods (all marked in the diagram), which are crowded near the surface, but which lengthen and are gradually obscured as we pass toward the axis. During this oscillatory march,  $\delta$  increases from values which lie below the glass-hard density almost as far as the density of the soft state. In other words, the interval of variation of density studied from point to point of a tempered rod is fully twice as large as the density interval hard-soft. Indeed, if we take into consideration that  $\delta$  is only the apparent structure, that the shells are not longitudinally homogeneous, but hard at the ends, it appears altogether probable that the density of soft steel will actually be reached. At the same time, it must be borne in mind that the density at about 0.7<sup>cm</sup> below the surface does not differ appreciably from the mean density of the core. Hence we infer fairly that from here on, inward, large fluctuations of  $\delta$  will no longer occur.

The inquiry next in importance is the relation of density at any point within the cylinder to the hardness there mechanically observed. To the occurrence of soft strata between the points marked *a* and *b* we have already adverted. But below this the steel appears exceptionally hard—so hard that the little ridges and furrows left on the surface by the diamond readily grind off the edges of a file or any other hard steel tool. This state of hard temper continues until we reach the points in the vicinity of *c* in the diagram, say 0.7<sup>cm</sup> below the surface. From here on the rod is quite appreciably filable near its equatorial parts, the ends, of course, retaining the intensity of hardness of the superficial shell.

After these remarks it is in place to pass in review the corroborative evidence obtained from the other cylinders. In no case is the periodicity so sharply pronounced, and were the data for Nos. 2, 3, 4 alone available it would escape detection. But the evidence by no means conflicts with the inferences adduced for No. 1. No. 2, for instance, shows the first and second minima (see diagram) in proper position. The inclosed maximum is not so distinctly marked. No. 2, however, was quenched from a temperature much below that of No. 1; and since the harmonic distribution of density is primarily a mechanical phenomenon, the importance of temperature is at once obvious. For similar reasons the periods of No. 4 are more obscure than those of No. 3. In all rods (Nos. 1 to 4) the first minimum is unmistakably located near 0.05<sup>cm</sup> of depth. The second minimum falls between 0.10<sup>cm</sup> and 0.15<sup>cm</sup> of depth; the third minimum in the three observed cases between 0.25<sup>cm</sup> and 0.30<sup>cm</sup>; the fourth minimum between 0.5<sup>cm</sup> and 0.6<sup>cm</sup> of depth. This accordance is too persistent to suggest mere chance coincidences.

Thoroughly distinct from these curves is the locus of the set of values for No. 6. The variations show almost simple periodicity around the glass-hard line as a position of equilibrium. A comparison of the curve

No. 6 with the curve Nos. 1 to 4 at once calls to mind the differences in the qualities of the steel used. Similarly to Nos. 2 and 3 we here find the density of external shell decidedly above that of the soft state. The material is probably poorly carburized; for even in the glass-hard state, hardness (mechanical) is not intense.

Having described the principal features of the phenomenon of structure somewhat minutely, it will be our next endeavor to account for the remarkable variations observed, at least in some provisional way. The methods which suggest themselves to us may be grouped in reference to two general heads, periodicity and carburization. But there are two ways of explaining periodicity: we may regard it as a real structural phenomenon, or we may regard it as a secondary occurrence, bearing no inherent relation to temper at all and due to intermittent shrinkage of the cylinder while in the hands of the operator. It is expedient to consider these questions in separate paragraphs.

*Possibility of harmonic distribution of density.*—Suppose we ignore the occurrence of periodicity for a moment and consider only the mean ascent of the loci for  $\delta$ . Then in case of steel of a given kind, subjected to a given operation of tempering, the hardness or density exhibited by any point is essentially dependent on the position of the said point below the surface, as our data show. The rate at which the point cools is similarly conditioned. Hence it is natural to associate the first phenomenon with the second, and to state that the hardness in a given point is a function of the rate at which cooling there takes place. Knowing the relative rates of cooling of consecutive shells we would have given us therewith a method for expressing hardness (estimated in units either of density or of resistance) in terms of rate of cooling. But the adequacy of such a mode of inquiry is incomplete, because the shells in question are parts of the whole, and not distinct individuals. The consideration simply suggests the cause for the gradual decrease of hardness from surface to axis.

Returning from this digression to the consideration of periodicity proper, we remark that solids, when subjected to shearing strains, usually exhibit low degrees of elasticity and experience marked changes of form. But all substances, whether solid, plastic, viscous, or liquid, when subjected to pure isotropic strains—in the present instance to a strain of compression equally distributed in the three cardinal directions—are probably very nearly perfectly elastic. Here, therefore, is a principle suggesting the possibility of vibratory movement, even in an intensely heated viscous solid. Suppose now there be given a small sphere of steel. Let this be heated above redness and then suddenly cooled (quenched) uniformly over the whole surface. Then we contend that it is not probable that during the initial stages of cooling contraction should manifest itself as a simple, aperiodic, static phenomenon.<sup>1</sup>

<sup>1</sup>Attention must here be drawn to to the Cumming-Gore phenomenon of sudden contraction at red heat. Cf. U. S. Geol. Surv. Bull. 14, p. 99.

We contend, in other words, that in consequence of sudden and enormous compression, virtually applied at the surface, the whole sphere during incipient cooling will be thrown into a state of vibration symmetrical with respect to the center of figure. Under the ideally perfect circumstances of quenching, therefore, the sphere must so vibrate that all points of any given spherical shell at a given time are in like phases of oscillation. It follows obviously, moreover, that in the case of a long cylinder suddenly and uniformly cooled, the phases of the elementary coaxial shells will, at a given time, be identical.

The necessary concomitant of the vibration specified is harmonic distribution of density; and the maxima and minima encountered may be made to differ by amounts as large as we please, up to a certain limit, by increasing the temperature from which cooling takes place. But while vibration is in progress the cylinder itself is cooling rapidly, or, in other words, the rigid shell closes inward from surface to center, *congealing*, as it were, and retaining permanently within itself the traces of the harmonic distribution of density in question.

More concisely: Let the sphere be of large radius. Then the density in a point at a normal distance,  $x$ , below the surface, at the time  $t$ , during the initial stages of cooling may be expressed by

$$\delta = a \sin \frac{2\pi}{\lambda} (vt - x + A) \dots \dots \dots (1)$$

where  $v$  is the velocity of propagation,  $\lambda$  the wave length,  $A$  a length phase.

Let  $x = \varphi(t); t = \psi(x) \dots \dots \dots (2)$

express the depth of the advancing inward boundary of the rigid shell<sup>1</sup> at the time  $t$ . Then the mathematical effect of congealing may be said to be equivalent to an *elimination* of  $t$  between equations (1) and (2); so that for the rigid sphere,

$$\delta = a \sin \frac{2\pi}{\lambda} (v\psi(x) - x + A) \dots \dots \dots (3)$$

a function of  $x$  only, applies. Equation (3) shows that the wave actually congealed need be identical in regard to neither phase nor wave length with the original wave  $\lambda$ ; that it will generally be very much larger. For instance, under the simplified conditions that  $x = \varphi(t) = m + nt$ , if we put

$$\text{arc ctg } n = \alpha \qquad \text{arc ctg } v = \beta$$

the congealed wave will exhibit the new phase  $A_1'$ , and new wave length,  $\lambda$ ,

$$A' = A - m \text{ and } \lambda = \lambda \frac{\sin \beta}{\sin (\beta - \alpha)} \dots \dots \dots (4)$$

respectively. According as  $\alpha$  lies anywhere between  $\beta - \frac{\pi}{2}$  and  $\beta$ ,  $\lambda$  may have any value between the limits  $\lambda \sin \beta$  and  $\alpha$ . But it is es-

<sup>1</sup>Rigidity may here be the result of chemical as well as of mechanical action (temperature). See p. 42.

essentially constant, and the periodicity uniform. Here we may remark in passing, that if shells of like thickness be etched off, the observed harmonic law will bear some such relation to the congealed periodicity as is expressed in equation (4).

If  $\varphi(t)$  be not linear but represent some more complex function, as it must in the case under consideration,  $A$  must also vary continuously. If, furthermore,  $n = d\varphi(t) / dt$ , and if  $n$  decrease continuously, then  $A$  will increase with  $x$  wherever  $n > v$ ; it will decrease with increasing  $x$  wherever  $n < v$ . The former of these criteria seems to be given by the diagram, Fig. 8; but it must be borne in mind that the curves there given are seriously distorted by other causes. The inference goes no further than to point out that the harmonic distribution of density must be of variable period; and that this variation will depend on the relative values of rate of wave propagation and rate of advancing rigidity.

As the process of cooling proceeds, the continually increasing thickness of rigid shell interferes with vibration in a way to obscure the periods more and more, as we pass from the surface inward. Within the shell the energy of vibration is largely potentialized. We have already pointed out that in the case of cylindrical figure true structure is related to the apparent structure,  $\delta$ , by the equation

$$f(x) = l_0 \int \frac{F'(x)}{l_0 - x}.$$

If  $F(x)$  be harmonic,  $f(x)$  will also be, with this limitation, however, that  $f(x)$  and  $F(x)$  cannot, at the same time, both be uniformly so. Probably neither will be; and we have a second condition for the variable periodicity observed. The effect of superficial decarburization on  $\delta$  is a third condition.

Perfect uniformity of sudden cooling or quenching is not practically attainable. Pressure is first applied at the parts of the hot cylinder which first touch the cold water, and it is not until the mass is fully submerged that the temperature, &c., of the surrounding medium is fairly uniform. Again, certain parts of the quenched body will always be more favorably placed in regard to contact with cold water than others. Hence the conditions are such that perfectly symmetrical arrangement of the parts of like given density relatively to the axis and center of figure of the steel body must be a very rare occurrence. True structure is therefore more or less fully obscured by the divers adventitious circumstances of chilling and by intentional or accidental variations in the operation of tempering itself.

The views here set forth are very well illustrated by the following little experiment: Let a ring capable of up and down motion be suspended with its plane always horizontal over a basin of water. If now the ring be lowered at regular intervals so as to dip into the water with all its parts at once, and if the period of oscillation of the ring be adjusted synchronously with the oscillation of the circular wave under it,

the whole surface of the water bounded by the ring may be made the field of regular and continued wave motion. Suppose now the water to congeal from the ring inward at some regular rate, then the congealed surface will show uniform periodicity, which will not, however, be identical with the period of the liquid surface. If the rate of advance be variable, the periodicity must be variable. Finally the conditions of practical quenching may be typified by the interferences resulting if the ring be dipped obliquely relative to the surface of the water.

*Intermittent shrinkage.*—Whatever the mechanical structure of steel is, it may be reasonably argued that the conditions of equilibrium at every point are in conformity with and influenced by the dimensions of the bar. Hence, if parts of the rod be removed, by solution or otherwise, we may look for an excess of stress in those parts; and if the process of removal be often repeated, this excess may eventually increase to an intensity sufficient to effect a permanent and sudden change of strain. A series of such changes would constitute the intermittent phenomenon in question.

Glass-hard steel is under a strain of dilatation. The probable effect of the removal of superficial coats is, therefore, contraction. We need only suppose that the greater part of such contraction takes place uniformly, in proportion as shell is being removed, to obtain the principal features of Fig. 7, Nos. 1 to 4; moreover, that sudden contractions of higher order, occurring intermittently for the reasons specified, are superimposed upon this main and uniform shrinkage to generate Fig. 8, Nos. 1 to 4. For since

$$\delta = \frac{\frac{\mu}{M_1}}{\frac{M_0}{M_1} \nabla_0 - \nabla_1} \quad \text{and} \quad d \delta = \frac{\frac{\mu}{M_1} d \nabla_1}{\left( \frac{M_0}{M_1} \nabla_0 - \nabla_1 \right)^2},$$

and since we may consider  $\mu$ ,  $M_0$ ,  $M_1$ ,  $\nabla_0$  constant in any given experimental case, it is obvious that if  $\nabla_1$  vary by small decrements, in consequence of contraction,  $\delta$  will vary by corresponding decrements, and conversely. If, therefore, we examine Fig. 8, No. 1, for instance, sudden contraction may have occurred between  $b$  and the first minimum, between the first maximum and the second minimum, between the second maximum and the third minimum, between the third maximum and the fourth minimum, and so on. Between any minimum and the next consecutive maximum we have usually a curve of gradual ascent, indicating normal changes of density.

Some evidence of contraction is contained in the above tables, and discussed under Errors, p. 48; but it is insufficient. On the other hand, no contraction could be discerned by resistance measurements at all (p. 31). The occurrence of shrinkage is, therefore, questionable, and more searching investigation may show it to be absent. Moreover, it would furnish no satisfactory explanation for certain degrees of like-



ness in the curves Nos. 1 to 4, to which we have already referred. After the removal of nearly 1<sup>cm</sup> of shell, hardness is still retained at the ends of No. 1, whereas it gradually vanishes near the middle parts. This, again, is adverse to the shrinkage hypothesis.

*Carburization.*—The probability of absence of true shrinkage to which we referred in the last paragraph, taken in connection with the great molecular stability of the shells in the divers specimens of steel examined, suggests that the intensity of the mechanical strain of glass-hard steel may possibly be overestimated. Mere superficial scratching is frequently sufficient to explode a Rupert's drop.<sup>1</sup> Glass-hard steel, on the other hand, may be reduced in thickness to quite one-third the original diameter, or again, thin rods (0.7<sup>cm</sup>) reduced to mere filaments without showing any thoroughly satisfactory evidence of shrinkage. In all the experiments made by the resistance method, hardness is found to increase very perceptibly from surface to core; the (thin) rods (radius = 0.3<sup>cm</sup>) are hardest at the axis. If, therefore, steel has once been subjected to an operation capable of evoking the strain of dilatation in question, the strain imparted appears to possess a certain permanence of character and to be able to maintain itself independently of the presence or thickness of the surrounding layers. In this respect it is peculiar. It yields readily to temperature only; and we infer that it owes its persistency to molecular or chemical agencies.<sup>2</sup> Suppose, therefore, that with the carbon available in steel it is possible under favorable circumstances to produce a variety of iron-carburets; in other words, that under favorable variation of circumstances, a certain latitude of density is a possible occurrence. Then we argue, plausibly, we think, that during the process of sudden cooling of steel from red heat the carbon and iron at any point within the body will unite (for the given degree of carburization) in correspondence and conformity with the intensity of strain there experienced; that, therefore, in the cold steel the strains are to a large extent permanent and independent of the condition of stress of the surrounding medium of steel.

The remarks just made will have shown how incomplete our knowledge of the phenomenon of structure as yet is, and where further experimentation is essential. The paragraph on periodicity postulates certain relations between velocity of wave propagation and rate at which rigidity advances inward. The occurrence of shrinkage is hypothetical and lacks satisfactory evidence; nor has direct quantitative measurement been brought to bear on the conditions of carburization.

<sup>1</sup> Our recent experiments show that the respective behaviors of steel and Rupert drops here in question are identical.—*August, 1886.*

<sup>2</sup> Conditions favorable to chemical combination (quenching); so difficult of attainment in case of low degrees of carburization (steel), are given at once in case of greater carburization (cast-iron), where mere cooling in air will harden. The mass of available carbon is therefore here an essential factor and the phenomenon in hand is probably an instance of mass action.

Nevertheless we believe that cautious blending of the three views advanced will reconstruct the actual phenomenon of structure as accurately as the data now in hand describe it.

*Resistance.*—The results in Table 7 show no pronounced periodicity. Considered individually, moreover, they would not be of much value. Considered as a whole they mutually sustain each other, and indicate a decided increase of resistance in passing from surface to core. Hardness increases rapidly inward, and this quality here exists in greatest intensity at the axis. These rods therefore show like behavior with No. 6, and the general structure is that of relatively dense external layers surrounding a relatively rare core. But it must be borne in mind that these rods are comparatively thin; that for greater thicknesses the loci will probably pass through minima of  $\Delta$  or maxima of  $S_0$  and of hardness, thereupon to enter into a second phase of variation, such as is exhibited by the  $\Delta$  of rods Nos. 1 to 4. Considered in this light, the minima in Fig. 7, Nos. 1 to 4, are to some extent critical points, inasmuch as their position varies in depth with the quality of steel employed, and is deepest for steel capable of withstanding a maximum of stress of the given kind.

Finally, it is well to remark that the data of the above tables, when interpreted in the manner given under carburation, conflict with received physical notions of temper and structure; for it appears that the equilibrium of stress at any point is maintained independently of the presence or absence of other layers. Hence, the deduction made in Bulletin 14, page 103, from data obtained with malleable cast iron, viz, that the electrical variations accompanying temper are evoked by strain, and are only to a smaller extent dependent on the conditions of carburation, does not follow in the way in which we there understand it.<sup>1</sup> In short, the present results make it questionable whether in the *cold* rod the effects due to strain and to carburation, respectively, can be sharply distinguished at all (cf. p. 42).

*Errors.*—In the present research some of the inferences are dependent on variations of the descriptive function,  $\delta$ , the order of which is not much above the aggregated effect of errors of observation. Hence a full enumeration of the divers sources of discrepancy, together with an analysis of the magnitude and distribution of their respective influences, is a matter of cardinal importance.

It seems expedient to commence with the observations proper, since it is here feasible to obtain good estimates for the amount of distortion probable in each case. If we define  $\delta_n$ , the density of the  $n$ th elementary shell, approximately by

$$\delta_n = \Delta_{n-1} - \frac{R_n}{2S_n} (\Delta_{n-1} - \Delta_n) \dots \dots \dots (1)$$

---

<sup>1</sup>Probably in malleable cast iron insufficient quantities of transmutable carbon are available, the metal being rich in graphite. The presence of neutral conducting substances obscures the electrical effect of temper.

we may regard the errors of  $\delta_n$  essentially conditioned by the values and variations of  $L$ ,  $\mathcal{S}$ ,  $\Delta_{n-1} - \Delta_n$ . The range of variation of these quantities has been

$$0.5 < R < 1.5 \dots \dots \dots (2)$$

$$0.01 < \mathcal{S} < 0.1 \dots \dots \dots (3)$$

$$0.0010 < \Delta_{n-1} - \Delta_n < 0.0050 \dots \dots \dots (4)$$

Hence, if to prevent confusion of signs we designate errors by prefixing the differential symbol " $d$ ," we easily deduce from (2), (3), (4), and partial differentiations of (1),

$$0.025 d\mathcal{S}_n < d\delta_n < 37.5 d\mathcal{S}_n \dots \dots \dots (5)$$

$$2.5 d(\Delta_{n-1} - \Delta_n) < d\delta_n < 75.0 d(\Delta_{n-1} - \Delta_n) \dots \dots \dots (6)$$

$$0.005 dR_n < d\delta_n < 0.25 dR_n \dots \dots \dots (7)$$

equations to be interpreted numerically. If we consider these cases one by one, we obtain as conditions under which (5) is least favorably and most favorably applicable:

$$d\mathcal{S}_n < 0.01; \quad 0.375 > d\delta_n > 0.00025 \dots \dots (8)$$

$$d\mathcal{S}_n > 0.001; \quad 0.037 > d\delta_n > 0.000025 \dots \dots (9)$$

respectively. Again, for the conditions under which (6) is least favorably and most favorably applicable,

$$d(\Delta_{n-1} - \Delta_n) < 0.0010; \quad 0.075 > d\delta_n > 0.0025 \dots (10)$$

$$d(\Delta_{n-1} - \Delta_n) > 0.0001; \quad 0.0075 > d\delta_n > 0.000025 \dots (11)$$

respectively. For (7), similarly,

$$dR < 0.01; \quad 0.0025 > d\delta_n > 0.00005 \dots \dots (12)$$

$$dR > 0.001; \quad 0.00025 > d\delta_n > 0.000005 \dots \dots (13)$$

respectively. An inspection of the inequalities (8) to (13) leads to the result that serious distortion from errors in the measurement of  $R$  need not be apprehended, but that the effect of errors of  $\Delta_{n-1} - \Delta_n$ , and to a much greater degree of  $\mathcal{S}$ , may, in unfavorable cases, influence  $\delta_n$  to an alarming extent. It is, therefore, desirable to discuss in detail the probable mean errors  $d\mathcal{S}$ ,  $d(\Delta_{n-1} - \Delta_n)$ ,  $dR$ , and to weigh as nicely as possible their influence on  $\delta$ . In order to do this, in a measure at least, we made duplicate direct determinations of  $\Delta$  after each removal of shell; and, similarly again, duplicate measurements of  $\mathcal{S}$  and  $R$ . The values for  $\Delta$ ,  $\mathcal{S}$ , and  $R$ , as resulting both from direct measurement and from indirect gravimetric measurement, are fully given in Tables 2, 3, 4, and 5. Table 9, however, contains a perspicuous comparison of the special differences between observed and calculated, here in question.

TABLE 9.—Exhibit of errors of  $R$  and of  $\vartheta$ .

No. 1.			No. 2.			No. 3.		
Shell.	$dR$	$d\vartheta$	Shell.	$dR$	$d\vartheta$	Shell.	$dR$	$d\vartheta$
1.....	-0.0003	-0.0022	1.....	-0.0017	-0.0033	1.....	-0.0064	+0.0005
2.....	+ 016	- 014	2.....	+ 009	- 10	2.....	- 06	- 19
3.....	+ 031	- 017	3.....	+ 017	- 14	3.....	+ 09	- 11
4.....	+ 052	- 022	4.....	+ 037	- 28	4.....	+ 57	- 55
6.....	+ 026	- 052	5.....	+ 061	- 22	6.....	+ 33	- 66
7.....	+ 000	- 096	6.....	+ 063	+ 19	7.....	+ 73	- 14
8.....	+ 091	+ 115	7.....	+ 058	- 07	8.....	+ 66	+ 29
9.....	+ 064	- 062	8.....	+ 100	+ 20	9.....	+ 57	- 10
10.....	+ 087	+ 017	9.....	+ 105	- 31	10.....	+ 76	- 34
11.....	+ 074	+ 009				11.....	+ 72	+ 47
12.....	+ 120	- 101				12.....	+ 42	+ 10
13.....	+ 124	+ 092						
14.....	+ 089	- 020						
15.....	+ 091	+ 014						
16.....	+ 104	- 041						
17.....	+ 108	+ 034						
18.....	+ 101	- 020						
19.....	+ 107	+ 008						
20.....	+ 077	+ 050						
Numerical mean .....	0.0072	0.0042	Numerical mean .....	0.0052	0.0020	Numerical mean.....	0.0050	0.0027

No. 4.			No. 6.		
Shell.	$dR$	$d\vartheta$	Shell.	$dR$	$d\vartheta$
1.....	+0.0025	-0.0012	1.....	+0.0171	-0.0014
2.....	+ 029	+ 07	2.....	+ 066	+ 24
3.....	+ 035	- 17	3.....	+ 060	- 14
4.....	+ 079	- 73	4.....	+ 081	- 27
5.....	+ 104	+ 25	5.....	+ 060	+ 68
6.....	+ 088	+ 08	6.....	+ 056	- 59
7.....	+ 086	- 05	7.....	+ 096	- 23
8.....	+ 060	+ 61	8.....	+ 106	- 05
9.....	+ 041	- 22	9.....	+ 083	+ 42
Numerical mean.....	0.0061	0.0026	Numerical mean.....	0.0086	0.0031

In constructing Table 9 it was thought expedient to facilitate computation by assuming  $l=6^{\text{cm}}$ . The uniform error thus introduced (except in case of No. 6, about which later) will not exceed a few tenths per cent. of excess. The unbroken character of  $dR$  is therefore attributable to other causes, principally to the fact that in view of the corroded or pitted surface of the cylinder after solution—in other words, in view of warty irregularities, which even the diamond does not satisfactorily remove—the measured value of  $R$  must be too large. To an important bearing of this result we have already alluded above (p. 31). In  $\vartheta$  this uniform error is largely eliminated, because  $\vartheta$  is essentially a difference.

If we take the numerical mean of the values of  $dR$  and  $dS$  for Nos. 1 to 6, respectively, the results must yield us as safe an estimate for the mean errors of  $R$  and  $S$  as is conveniently obtainable, even though this method be not punctiliously rigid. Table 10 shows the value of  $d\delta$ , corresponding to the numerical mean values under consideration (Table 9) for each of the cylinders Nos. 1 to 6, and for mean value of  $R$ ,  $S$ ,  $\Delta$ . The table is readily intelligible, since  $d\delta$  is the influence of the error placed on the same horizontal row.

TABLE 10.—*Calculated (mean numerical) errors of  $\delta$ .*[ $R = 1.0$ ;  $\vartheta = 0.05$ ;  $\Delta_{n-1} \Delta_n = 0.0025$ .]

No.	$dR$	$dS$	$d(\Delta_{n-1} \Delta_n)$	$d\delta$
1.....		0.0042		0.0020
			0.0005	0.0050
	0.0072			0.0002
2.....		0.0020		0.0010
			0.0005	0.0050
	0.0052			0.0001
3.....		0.0027		0.0013
			0.0005	0.0050
	0.0050			0.0001
4.....		0.0026		0.0013
			0.0005	0.0050
	0.0061			0.0002
6.....		0.0031		0.0016
			0.0005	0.0050
	0.0086			0.0002

The distortion due to errors of observation enters very fully into the third decimal and may affect the second. Its mean value will not be greater than a few tenths per cent. This is by no means sufficient to invalidate the observed harmonic character of Fig. 8. It is indeed only just sufficient to permit us to replace the jagged outline of the diagram by well-rounded contours.

These data are so important as to urge further search for corroborative evidence. Fortunately, results for this end are in hand. In Tables 3 and 5 we derive  $\delta$  in two ways: first, as depending on mass and density alone; secondly, as depending on dimensions and density alone. The two methods of computation both contain  $\Delta$ , and are therefore not wholly distinct; but they differ from each other by one essential variation at least; and although it is again not rigidly precise, it is sufficiently in keeping with the present purpose to regard the difference between the respective values of  $\delta$  as a fair estimate for the error of this quantity. For the sake of facilitating expression or of deriving a single final result, we will go one step further and regard the differences between observed and calculated  $\delta$ , in Tables 3 and 5, as errors of  $\delta$  considered for the time being as a constant quantity. With this assumption we

reach a concise expression for the mean error of one observation. In consequence of the transcendental character of the dependence of  $\delta$  on  $R$ , we know of no better method for making this evaluation. The individual and the mean errors thus derived are summarized in Tables 11 and 12.

TABLE 11.—*Exhibit of errors of  $\delta$ , first series.*

No.	Shell.	Error.	No.	Shell.	Error.	No.	Shell.	Error.
1.....	1	+0.003	1.....	11	$\pm 0.000$	3.....	1	-0.010
	2	- 17		12	- 07		2	+ 03
	3	+ 03		13	$\pm$ 00		3	$\pm$ 00
	4	+ 01		14	+ 04		4	- 05
	5	.....		15	+ 01		6	- 03
	6	- 07		16	- 03		7	- 01
	7	- 07		17	+ 01		8	+ 02
	8	+ 02		18	+ 00		9	- 03
	9	- 11		19	- 01		10	- 03
	10	+ 02		20	+ 01		11	$\pm$ 00
							12	- 01
			Mean error.....		$\pm 0.0058$	Mean error.....		$\pm 0.0041$

TABLE 12.—*Exhibit of errors of  $\delta$ , second series.*

No.	Shell.	Error.	No.	Shell.	Error.	No.	Shell.	Error.
2.....	1	+0.015	4.....	1	$\pm 0.000$	6.....	1	+0.002
	2	- 10		2	$\pm$ 00		2	- 14
	3	- 02		3	- 01		3	$\pm$ 00
	4	- 03		4	- 07		4	$\pm$ 00
	5	- 04		5	$\pm$ 00		5	- 03
	6	+ 01		6	+ 00		6	+ 04
	7	+ 02		7	- 01		7	+ 02
	8	- 01		8	+ 01		8	$\pm$ 00
	9	- 04		9	- 01		9	$\pm$ 00
Mean error.....		$\pm 0.0069$	Mean error.....		$\pm 0.0026$	Mean error.....		$\pm 0.0054$

The magnitude of errors contained in Tables 11 and 12 is in excellent accordance with the corresponding data in Table 10. The methods of discussion are quite distinct and independent. We therefore infer with some confidence that, so far as errors of the class under consideration go, the periodic nature of the dependence of the density at a given point within the cylinder on the depth of the same point below the surface cannot be annulled or brought to merge into simpler functions.

Alike in order of importance are such errors as depend on the state of the surface of the cylinders. After removal of a shell by solution the surface is rarely glossy, most usually pitted, furrowed, and rough. In this case accurate measurement of  $\Delta$  is quite difficult, because it is not easy to cleanse the surface thoroughly, either of adhering sheets of invisible air bubbles or of carbon, rust, or even metallic precipitate.  $\Delta$  obtained from rough surfaces is therefore presumably

too small. The objections here in question are obviated if the surface be trued and polished on the lathe with a diamond master tool; but this process may introduce a new error, even if proper precaution be taken for turning under water. The rise of temperature resulting from friction, or, indeed, the merely mechanical effect of scratching, may change the superficial temper very appreciably. In other words, the thermal effect of friction may be quite insignificant when distributed over the cylinder as a whole; but its effect in changing the stress under which the superficial shell is supposed to exist may nevertheless be marked. We take from the above tables a few data to corroborate these remarks. Roman indices refer to cylinders by number; Arabic subscripts, to shells.

TABLE 13.—*Density effect of friction.*

No., &c.	Rough.	Smooth.	Difference.	$d\delta$ .
$\Delta_1^{ii}$ .....	7.7864	7.7892	+0.0028	+0.03
$\Delta_{12}^{iii}$ .....	7.7646	7.7666	+0.0020	+0.02
$\Delta_2^{ii}$ .....	7.7888	7.7900	+0.0012	+0.01
$\Delta_2^{iv}$ .....	7.7734	7.7753	+0.0019	+0.02
$\Delta_1^{vi}$ .....	7.7980	7.8015	+0.0035	+0.04
$\Delta_{13}^j$ .....	7.7890	7.7933	+0.0043	+0.04

Density is increased by turning to an amount as large as corresponds to the removal of a single shell; and the discrepancy  $d\delta$  resulting may be even one-half per cent. of the density of shell sought. The part of this increment due to roughness of surface and the part due to superficial annealing cannot be distinguished; but it is clear that the data will only be sufficiently accurate for the present comparisons when cylinders of like surface, preferably smooth, are examined. If we inspect the equation of errors here involved,

$$2d\delta_n = R_n (\Delta_{n-1} - \Delta_n) \frac{-dS_n}{S_n^2} + \frac{R_n}{S_n} d(\Delta_{n-1} - \Delta_n) + \frac{\Delta_{n-1} - \Delta_n}{S_n} dR_n,$$

we find  $d\delta_n$  alarmingly large when the shells are thin. Such data cannot be regarded as valid until they have been subjected to most careful and searching scrutiny.

Curiously enough, even if the rough cylinders be tested from time to time, density seems to increase. This may be regarded as an indication of slow shrinkage. Here are a few results,  $h$  denoting the interval in hours:

TABLE 14.—*Effects possibly due to shrinkage.*

No., &c.	$h$	$\Delta$	Difference.
$\Delta_1^{iv}$ .....	0	7.7727	} +0.0011
	50	7.7738	
$\Delta_1^{vi}$ .....	0	7.8000	} +0.0022
	50	7.8022	

The data are again of the same order as the differences of density obtained by removing a single shell. Here, therefore, is a source of error the effects of which cannot as yet even be estimated. The few data given merely suggest the importance of special inquiry.

A third class of errors results from the fact that it is nearly impossible to preserve perfect cylindricality throughout the course of the experiment. Solution is liable to take place at greater rates near the ends of the pieces of steel, as well as irregularly over the surface. The removal of matter in too great quantity from the ends must be particularly apprehended. This difficulty may be corrected to some extent by painting with asphaltum; but it is not thoroughly counteracted. Even the diamond polishes the surface without necessarily restoring the cylindrical figure completely. Hence unless great care be taken, the cylinders, after repeated solutions of shells, become more and more convex and barrel-shaped, and hence if the infinitesimal shells of the hard cylinder be coaxial and symmetrical with respect to its equator, the dissolved shell is not in full coincidence with a series of elementary shells of the cylinder. Moreover, the discrepancy is greater as the harmonic distribution of density is of small period or crowded. In such a case the true periodicity may wholly escape detection.

Again the density,  $\delta$ , directly obtained is not the true density for the given distance,  $x$ , below the surface. This follows readily if it be called to mind that the structure of the tempered cylinder must be that of box-within-box. Hence if we consider the distribution of density along the  $n$ th elementary shell we must find, on passing from equator to either end, a general increase to a maximum simply because we approach parts near an end surface of the original cylinder. The analysis has already been given.

The final source of error is readily detected. We refer to superficial oxidation. It is obvious that the rapid descent of the loci of both  $\Delta$  and  $\delta$  for points near the surface is partially a secondary phenomenon, a simple physical expression for decarburization. To this we have already adverted (p. 33). We may add here that cracks are apparently accompanied by small values of  $\Delta$  (p. 34).

It will hardly be necessary to refer to the actual measurements. The water in which steel is frequently immersed soon shows yellowish turbidity, due to suspension of rust. In replacing this by fresh water, we invariably weighed the bodies (steel) in both; but the differences between the respective values of density were negligible in all cases.

The results of this discussion may be tersely summarized thus: A first approximation reveals structure ( $\delta=f(x)$ ), as a simple function of depth ( $x=\rho_0-\rho$ ) below surface, nearly independent of radius; more accurate approximation suggests an exceedingly complicated, probably harmonic function of depth. Final decision as to whether the harmonic relations in hand are true expressions for the variations of structure involved, or



whether they simply indicate a periodic distribution of errors, can alone be given by frequent and laborious *repetitions* of experiments like those here described, with comparisons of all the loci obtained. The experiments must include many types of steel; for it is in this work that the quality of the material enters as a factor of exceptionally great importance. We come at once in contact with the power of retaining stress postulated in our earlier bulletin.

#### CONCLUSION.

The general results of the present paper have been so fully summarized in the preceding paragraph that further remarks here are nearly superfluous. But there are certain ulterior points at issue which have not yet been touched upon. In the first place, it is clear that the investigation of structure, which the present paper merely commences for the glass-hard state, is incomplete; that it must be supplemented by the nearly equally important series of data for the other definite states of temper between hard and soft. In Bulletin 14 we studied the phenomenon of annealing in its gross or aggregated effects; but the minute analysis of this phenomenon must, under given circumstances of exposure, necessarily discern differences of hardness at each point of the rod annealed. It must distinguish between the paths, as we may say, by which the consecutive individual shells eventually reach the state of homogeneous temper, while the rod as a whole passes from hard to soft.

An important observation is the dependence of structure on the quality or kind of steel carrying the hard strain, so that it may even be a sensitive criterion of the character of the material employed. Certainly it is difficult to avoid the inference that the lauded theory of dense shell and rare core, or hard shell and soft core, when regarded as a faithful expression for the structural results of temper, is quite incomplete. Under given conditions of quenching and for a given kind of steel, the hardness at a point is dependent upon the position of the said point below the surface, and will be harder or softer than the superficial layers in proportion as we pass through greater values of depth. Hence, so long as crucial evidence for or against viscous shrinkage (i. e., continuous variation of strain due to purely mechanical causes) is not in hand, so long as the strain at any point of a tempered-steel bar is persistent and *apparently* independent of the strain of surrounding parts, it will be safest to return to the venerable hypothesis of combined carbon, much in the form in which Karsten and his stalwart associates left it.<sup>1</sup>

---

<sup>1</sup>We have since examined the question of structure from a variety of different standpoints. It is difficult to give satisfactory excerpts here; and the reader is therefore referred to the American Journal of this year and to forthcoming Bulletins of the Survey.—August, 1886.

## B.—THE COLOR EFFECT PRODUCED BY SLOW OXIDATION OF IRON-CARBURETS.

Under this head we desire to continue the investigation on certain color phenomena peculiar to iron-carburets commenced in an earlier bulletin.<sup>1</sup>

Let there be given an oxide film bounded by two parallel planes, indefinite in extent, the anterior plane being continually in contact with air, the posterior plane continually in molecular contact with iron. Let the degree of oxidation at all points of any parallel plane between them be identical. If  $O$  be the oxidation in an interface at a distance  $x$  below the anterior surface, then we regard  $-dO | dx$  as an important factor of the force in virtue of which oxygen is urged normally through the interface, in an inward direction. And, furthermore, since during the whole growth of the film the inner and outer coats remain in contact

with iron and air, respectively, we must infer that  $\int_0^x dO$ , the differ-

ence between the degrees of oxidation of the two extreme surfaces, is constant. Hence the mean value of  $dO | dx$  must decrease in proportion as the coat increases in thickness, and hence oxidation ceases completely after a certain finite thickness of film has been formed. Experiment shows that at each temperature the depth of film below which oxygen cannot penetrate is a quantity of definite value, increasing as temperature increases. We find moreover that oxidation advances as far as the said maximum depth gradually at a slowly decreasing rate through infinite time.

In the case of ordinary diffusion  $-dO | dx$  would be a continuous function of  $x$ . In the present instance, however,  $-dO | dx$  is not necessarily continuous. Regarding the character of  $-dO | dx$  no further remark can here be made than that it must decrease continually from the anterior to the posterior face of a film. It is known that the oxide which forms on iron during heating is not of definite chemical composition. According to Roscoe and Schorlemmer<sup>2</sup> the inner layers are not magnetic and approximately  $6 \text{ Fe O Fe}_2 \text{ O}_3$ . The outer layers contain more ferric oxide and are magnetic. This result for thick layers does not, however, bear any immediate relation to the composition of extremely thin films, for, after the coat has increased to a certain thickness it cracks, and the phenomena are then repeated in promiscuous and irregular succession. The considerations suggested lead directly to the grained structure of matter, and we have remarked elsewhere that the oxygen molecule does not penetrate deeper than a few thousand times its own dimensions. Nevertheless the convenience of a function like  $-dO | dx$ , continuous throughout the great parts of its extent, at least, is obvious.

<sup>1</sup> U. S. Geol. Surv. Bull. 27, p. 51, 1885.

<sup>2</sup> Roscoe and Schorlemmer, Chemistry, 1884, II, 2, p. 86..

Our observations are as yet by no means sufficiently advanced to enable us to express the final (time =  $\infty$ ) thickness of film in its dependence on temperature. The data of the former paper, moreover, are incomplete in two respects: they contain only isolated values for the early stages of oxidation, which stages are important because they exhibit the time effect perspicuously; they furnish no results at all for the oxidation effect of low temperatures. To supply these deficiencies is the main object of this paper.

The method of experimentation here adopted is identical with that of the former paper. It was found expedient, however, to allow the flame of the burner to impinge upon a broad plate of brass; to place the shaft with its horizontal asbestos screen properly adjusted, upon the plate. This insures greater constancy of temperature throughout the area of base. Moreover, no discrepancy due to hot-air currents coming directly from the flame is to be apprehended. To obtain lower temperatures along the given length (25<sup>cm</sup>) of shaft, we found it fairly expedient to use two brass plates with an interposed sheet of asbestos.<sup>1</sup> By this device the range of temperature, 180° to 300°, was reduced as far as 110° to 160°. Certain objectionable features are to be mentioned below.<sup>2</sup> If care be taken to avoid these, the apparatus will furnish ample facilities for the complete researches on temper value contemplated.

*Data for high temperature.*—The results contained in Tables 15 to 18 were investigated with a view to corroborating the results of an earlier paper.<sup>3</sup> The range of temperature here lies within 180° to 260°, and the dark bands or zones (colors of higher order) are to be observed chiefly during the initial stages of oxidation.

In Table 15 the approximate positions of the color zones are given by noting as accurately as possible the consecutive depths (in centimeters) of the upper and lower boundaries of the respective zones below the top of shaft as a datum. *h*, here, is the time in hours dated from the moment at which the experiment was started. The figures under "remarks" refer to the observed depth of the center of color of the "clear blue" band. The column "dark" contains data for all shades of the variously-tinged blacks which follow the gray.

In Table 16 we give results for the successive distributions of temperature on the shaft. "No." refers to the thermo-element of platinum and platinum-iridium (20 per cent.) used.  $e_{20}$  is the electromotive force of this couple when the hot junction is applied at a depth, *d*, and the cold junction kept constantly at 20°. From this, *t*, the temperature in degrees centigrade is calculated. The means of the results for temperature and depth are summarized in Table 17.

On the basis of Tables 15, 16, 17 we computed the results in Table 18. The depths and mean temperatures of the successive color bands are

<sup>1</sup> See Fig. 10, p. 59.

<sup>2</sup> See p. 58.

<sup>3</sup> U. S. Geol. Surv. Bull. No. 27, p. 51.

here given for each time of observation. The results for clear-blue, having been specially redetermined, are probably more accurate than the others.

TABLE 15. — Consecutive positions of the color bands.

Date.	h	Dark.	Steel-gray.	Light-blue.	Clear-blue.	Purple.	Brown.	Yellow.	Colorless.	Remarks.
1885.										
Sept. 15..	0								25-0	Flame started.
	1.5								25-0	Top above 100°. Bottom just visibly darkening.
	2.7							22-	-0	24.5.
	5.5				25-24	24-22	22-		-0	24.0.
	8.2				25-22	22-20	20-		-0	23.5.
	9.5				25-22	22-21	21-	-19	19-0	23.
Sept. 16..	24		25-	-22	22-19	19-18	18-	-10	10-0	20.
	33		25-21	21-20	20-19	19-17	17-	-8	8-0	19.5.
Sept. 17..	48		25-21	21-19	19-18	18-16	16-10	10-5	5-0	19.5.
	53		25-21	21-19	19-18	18-16	16-10	10-0		18. (Shaft may be considered colored throughout its length.)
Sept. 18..	72	25-24	24-21	21-19	19-17	17-15	15-0	0-0		18.
Sept. 19..	96	25-23	23-19	19-18	18-16	16-14	14-12	12-0		17. (Streaks of blue spoil the purity of color.)
	104	25-23	23-20	20-18	18-16	16-10	10-	-0		
Sept. 20..	120	25-23	23-19	19-18	18-15	15-13	13-	-0		16.5.
Sept. 21..	144	25-23	23-19	19-17	17-15	15-14	14-10	10-0		16.
Sept. 22..	168	25-22	22-18	18-16	16-14	14-12	12-	-0		15.
	175									15.

TABLE 16. — Successive distributions of temperature.

Time.	No.	d	e <sub>20</sub>	t	Time.	No.	d	e <sub>20</sub>	t
h				°	h				°
10.....	35	0	1360	178	58.....	35	24	2141	260
10.....	35	12	1470	191	96.....	35	0	1243	164
10.....	35	24	2053	253	96.....	35	12	1439	187
34.....	35	0	1284	170	96.....	35	24	2009	247
34.....	35	12	1533	197	145.....	35	0	1277	170
34.....	35	24	1975	245	145.....	35	12	1506	194
58.....	35	0	1243	160	145.....	35	24	2113	258
58.....	35	12	1455	190					

TABLE 17.—Distribution of temperature—mean values.

$d = \dots\dots\dots$	0	5	10	15	20	23
$t = \dots\dots\dots$	169	175	186	202	227	247

TABLE 18.—Average temperatures of the successive color bands.

Date.	$h$	Gray.		Light-blue.		Clear-blue.		Purple.		Brown.		Yellow.		Colorless.	
		$d$	$t$	$d$	$t$	$d$	$t$	$d$	$t$	$d$	$t$	$d$	$t$	$d$	$t$
Sept. 15, 1885	0														
	2.7					24	280								
	5.5					24	270	23	260						
	8.2					23	265	20	232						
	9.5					23	260	21	240			20	232	19	225
Sept. 16, 1885	24	24	270			20	232	19	225					10	185
	33	23	260	21	240	19	229	18	219					8	178
Sept. 17, 1885	48	23	260	20	232	18	225	17	214	14	200	7	177	5	172
	58.	23	260	20	232	18	220	17	214	14	200	5	172	0	168
Sept. 18, 1885	72	23	250	20	232	17	216	17	214	12	191	5	172		
Sept. 19, 1885	96	21	240	19	225	17	214	15	204	13	195	6	173		
	104	21	240	19	225	17	214	13	195						
	120	21	240	18	219	16	211	14	200						
Sept. 21, 1885	144	21	240	18	219	16	209	14	200	12	191	5	172		
Sept. 22, 1885	168	20	230	17	214	15	204	13	195						
	175					15	202								

In the accompanying figure (Fig. 9) the temperature at the center of figure of the clear blue band is graphically represented in its variation with time. The diagram contains both present and early obser-

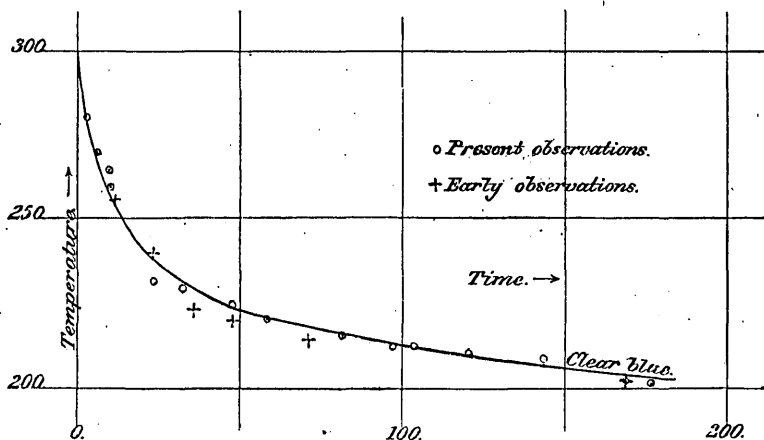

FIG. 9. Temperature of the mean "clear blue" film, regarded as a function of time.

ervations, the former being distinguished by small circles, the latter by crosses. Table 18, moreover, would enable us to construct similar loci

for the zones gray, light blue, purple, brown, yellow, colorless. But the data for these colors are neither so complete nor so accurate; they show like contours with the clear-blue curve, and differ from it chiefly in position. They are omitted to avoid confusion in the diagram.

The discrepancy between the present and former loci clear blue is nowhere larger than  $10^{\circ}$ . In consideration of the large sources of error and uncertainty involved in color measurements, this accordance is obviously satisfactory. We obtain a thorough corroboration of the earlier result, viz, that the conditions under which any given color is reached in normal atmospheric air depend both on the time and on the temperature of exposure in such a way that the influence of time more and more nearly vanishes in proportion as the exposure is indefinitely prolonged. Ultimately, therefore, the color datum is a function of temperature only.

When the (hot) shaft is allowed to cool after the ordinary circumstances of exposure, we find that after 6 hours of cooling it is just warm to the touch. We infer, conversely, that the thermal condition must necessarily become stationary within the first 10 hours of heating. Now, the upward movement of the color zones on the shaft is still marked after 200 hours, and hence cannot be seriously distorted by irregularities of heating at the inception of the experiment.

We may remark that when spread over large areas of planed wrought iron the oxide coloration is apparently less brilliant than when comprehended between isothermals lying very closely together. Probably streaks of color due to irregularities in the surface (unpolished) interfere with the purity of the tints. Hence the use of thinner cylindrical rods which the colors, as a whole, would encircle like a narrow girdle may be quite as good a method of experiment as the present: for temperature may be interpolated with accuracy for observations made at points of the rod on both sides of the girdle. Such rods should be of steel and well polished.

*Data for low temperature.*—Tables 19, 20, 21, and 22 are constructed on the same plan as Tables 15, 16, 17, and 18, and differ from them only in that the results given hold for lower ranges of temperature. The tables follow. Depths are expressed in centimeters, time in hours, temperatures in degrees centigrade.

TABLE 19.—*Consecutive positions of the color bands.*

Date.	<i>h</i>	Blue.	Purple.	Brown.	Straw-yellow.	Light-yellow.	Colorless.	Remarks.
Sept. 26, 1885	0							Experiment started.
Sept. 27, 1885	23					25-22	22-0	Color scarcely perceptible.
Sept. 28, 1885	48					25-21	21-0	
Sept. 30, 1885	87					25-21	21-0	Color still very faint.
Oct. 2, 1885	137			25-23	22-20	20-14	14-0	
Oct. 3, 1885	161			25-23	23-19	19-12	12-0	
Oct. 6, 1885	233		25-24	24-22	22-19	19-12	12-0	
Oct. 7, 1885	257		25-23		23-19	19-14	14-0	
Oct. 8, 1885	280		25-23	23-21	21-19	19-14	14-0	
Oct. 9, 1885	305		25-22		22-18	18-14	14-0	
Oct. 10, 1885	334		25-22	22-20	20-17	17-12	12-0	
Oct. 11, 1885	353		25-22	22-20	20-18	18-14	14-0	
Oct. 13, 1885	401	25-24	25-22	22-20	20-17	17-13	13-0	
Oct. 14, 1885	425	25-24	25-22	22-19	19-17	17-13	13-0	
Oct. 16, 1885	478	25-24	25-22	22-19	19-17	17-13	13-0	
Oct. 17, 1885	498	25-24	24-21	21-19	19-17	17-12	12-0	
Oct. 20, 1885	568	25-24	24-22	22-19	19-16	16-12	12-0	
Oct. 22, 1885	616	25-24	24-22	22-19	19-16	16-12	12-0	
Oct. 23, 1885	644	25-24	24-21	21-18	18-15	15-12	12-0	
Oct. 25, 1885	688	25-24	24-22	22-18	18-16	16-12	12-0	
Oct. 26, 1885	711	25-24	24-22	22-19	19-17	17-12	12-0	
Oct. 29, 1885	789	25-24	24-22	21-19	19-16	16-12	12-0	
Nov. 2, 1885	887	25-24	24-22	22-18	18-15	15-12	12-0	
	890							Gas out.
	890	25-23	23-21	21-19	19-17	17-14	14-0	} Remaining faces of the cold shaft. <sup>a</sup>
	890	25-24	24-22	22-19	19-18	18-13	13-0	
	890	25-23	23-20	20-18	18-16	16-11	11-0	

<sup>a</sup> The thick asbestos screen surrounding the shaft covers the part between 25.0 and 24.5. This part is faintly discolored as a consequence.

TABLE 20.—*Successive distributions of temperature.*

Time.	No.	<i>e</i> <sub>20</sub>	<i>d</i>	<i>t</i>	Time.	No.	<i>e</i> <sub>20</sub>	<i>d</i>	<i>t</i>
<i>h</i>					<i>h</i>				
23	35	749	0	111	280	35	771	0	113
23		849	12	124	280		867	12	125
23		1142	24	154	280		1197	24	160
48	35	774	0	114	385	35	752	0	110
48		892	12	126	385		849	12	124
48		1216	24	162	385		1192	24	159
87	35	764	0	113	575	35	740	0	109
87		887	12	126	575		860	12	125
87		1199	24	160	575		1174	24	156
137	35	745	0	110	715	35	698	0	105
137		867	12	125	715		843	12	121
137		1166	24	157	715		1118	24	152
185	35	791	0	115	890	35	655	0	100
185		889	12	126	890		763	12	111
185		1224	24	162	890		1056	24	146

TABLE 21.—Distribution of temperature—mean values.

<i>d</i> = .....	0	5	10	15	20	23
<i>t</i> = .....	110°	113°	119°	129°	143°	154°

TABLE 22.—Average temperatures of the successive color bands.

Date.	<i>h.</i>	Blue.		Purple.		Brown.		Straw-yellow.		Light-yellow.		Colorless.	
		<i>d.</i>	<i>t.</i>	<i>d.</i>	<i>t.</i>	<i>d.</i>	<i>t.</i>	<i>d.</i>	<i>t.</i>	<i>d.</i>	<i>t.</i>	<i>d.</i>	<i>t.</i>
Sept. 26, 1885	0	...	300	...	280	...	260	...	240	...	220	...	200
Sept. 27, 1885	23	...	...	...	...	...	...	...	...	...	22	...	149
Sept. 28, 1885	48	...	...	...	...	...	...	...	...	23	154	21	145
Sept. 30, 1885	87	...	...	...	...	...	...	...	...	23	154	21	145
Oct. 2, 1885	137	...	...	...	...	24	157	21	145	17	134	14	126
Oct. 3, 1885	161	...	...	...	...	24	155	21	145	16	130	12	123
Oct. 6, 1885	233	...	...	24	160	23	153	21	144	16	134	12	123
Oct. 7, 1885	257	...	...	24	157	...	...	21	145	16	134	14	126
Oct. 8, 1885	280	...	...	24	157	22	149	20	144	16	134	14	126
Oct. 9, 1885	305	...	...	24	155	...	...	20	144	16	132	14	126
Oct. 10, 1885	334	...	...	24	155	21	146	19	137	15	128	12	123
Oct. 11, 1885	353	...	...	24	155	21	146	19	140	16	132	14	126
Oct. 13, 1885	401	24	160	23	154	21	146	19	137	15	129	13	125
Oct. 14, 1885	425	24	160	23	154	20	144	18	136	15	129	13	125
Oct. 16, 1885	478	24	160	23	154	20	144	18	136	15	129	13	125
Oct. 17, 1885	498	24	160	22	151	20	143	18	136	14	127	12	123
Oct. 20, 1885	568	24	160	23	154	20	144	18	135	14	126	12	123
Oct. 22, 1885	616	24	160	23	154	20	144	17	135	14	126	12	123
Oct. 23, 1885	644	24	160	23	154	20	143	16	134	13	126	12	123
Oct. 25, 1885	688	24	160	23	154	20	143	17	134	14	126	12	123
Oct. 26, 1885	711	24	160	23	154	20	144	18	136	14	127	12	123
Oct. 29, 1885	789	24	160	23	154	20	143	17	134	14	126	12	123
Nov. 2, 1885	887	24	160	23	154	20	143	17	134	14	126	12	123

An inspection of the loci of the data given in Tables 19 to 22, where for stated colors mean temperature is expressed in function of time, shows this: In most cases only such parts of the respective curves as are almost indistinguishable from the asymptotes have been observed. In the earlier Bulletin,<sup>1</sup> and in the first parts of the present paper, evidence was adduced to prove that the influence of temperature to produce color bands, the order of which increases continuously with time, is particularly marked during the first 100 hours of exposure and is very nearly complete within 200 hours. In Tables 19 to 22 the blue purple bands did not rise observably above the horizontal screen until more than 200 hours had elapsed after the beginning of the experiment. These bands, moreover, extend upward not more than 2<sup>cm</sup> above the base of the shaft. At points so near the bottom the fluctuations in the intensity of flame are not yet either obliterated or rounded. It is therefore pos-

<sup>1</sup>U. S. Geol. Surv. Bull. 27, p. 51.



sible that during the night hours, or at other times when measurements were not made, these parts may have temporarily shown temperatures appreciably above the mean values of the set of ten series of measurements in hand. Hence the dark bands may owe their origin to temperatures above the exceptionally low values given in the tables. Finally, at points near the base and (hot) screen, oxidation is probably accelerated because the oxidizing air impinges at a temperature necessarily higher than is that of the air near the upper parts of the shaft. This, therefore, is a second cause for the unusually low temperatures at which dark zones have here been obtained.

Remarks of a similar kind apply in a measure to the dark yellows—brown and straw-yellow. The colors did not emerge above the screen, and hence observation was not feasible until 100 hours after the beginning of the experiment. The lines obtained are practically asymptotes; the temperatures are too low.

The present set of measurements is therefore interesting chiefly because of the values obtained for the oxidation of low temperatures. The light yellow and colorless parts of the shaft are so high above the base that the objections which hold for dark bands are no longer applicable. Moreover, the temperature discrepancy in question can only give additional weight to the inferences presently to be drawn. It appears, therefore, that under ordinary atmospheric conditions temperatures falling below  $125^{\circ}$  will not perceptibly oxidize iron (color effect), however long their action may be continued. It appears, furthermore, that the effect of temperatures near this limit is such that the final tint or color of highest order is in any given case reached in a comparatively short time; or that it is reached at a stage of progress certainly quite as early as that observed for dark bands. Here, then, we observe a difference in the temper effect and the color effect of temperature; since in the former case (of annealing) the influence of time is particularly marked for lower temperatures ( $<100^{\circ}$ ); whereas for higher temperatures ( $>200^{\circ}$ ) it is nearly negligible. The result for color phenomena is almost the converse of this, since the time effect here is rather more marked, and prolonged through greater intervals, for dark bands than for very light bands. Finally we may observe, in a general way, that the annealing effect of the action of temperature on hard steel is as nearly complete in a few hours as is the color effect in a few hundred hours—a difference which will probably be crucial.

The color phenomena in question may be made to appear in another aspect. We may discuss the rate at which for a given temperature the thickness of coat varies when exposure is prolonged indefinitely. A method of using monochromatic light of wave length  $\lambda$  and of determining the thickness  $d$  of film from  $d = n \frac{\lambda}{4}$ , where  $n$  is the order of the band, is here inapplicable. The bands are too broad and diffused and the temperature variation within the first band is of considerable importance.

Nevertheless, the colors appearing in white light are available for obtaining the datum sought, and the above results may thus be interpreted. It is, however, best to omit this comparison here. For the purpose in question, it is desirable to obtain the colors in the state of extreme purity in which they appear on a *polished* steel cylinder. Mr. William Grunow, of West Point, has been at great pains to furnish us with a steel shaft of this kind, 25<sup>cm</sup> long and 6.5<sup>cm</sup> in diameter. The shaft in position, M M M M, is shown in the accompanying diagram, Fig. 10, in which *a a* are plates of metal between which a sheet of

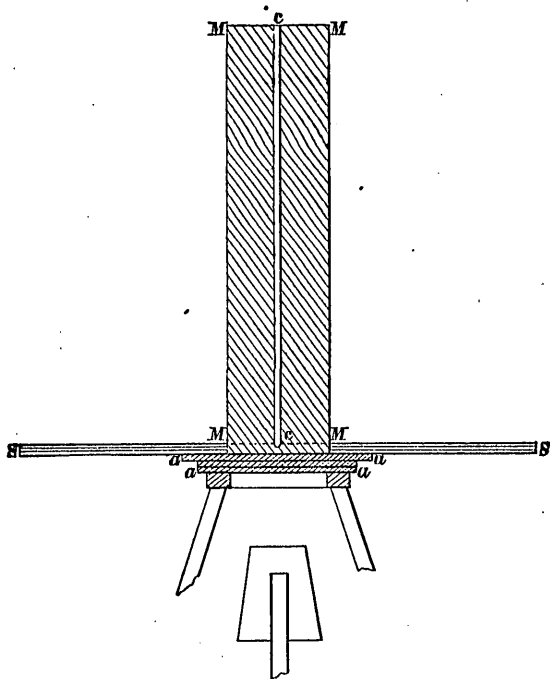

FIG. 10. Grunow's shaft, in position.

asbestos may be interposed. A screen, S S, fully 35<sup>cm</sup> in diameter, protects the shaft from direct flame currents. The essential feature of this arrangement is the vertical hole *c c*, 0.5<sup>cm</sup> in diameter, and extending to within a few millimeters of the base. Into this we purpose to introduce, momentarily, a properly insulated thermo-couple to determine the thermal distribution throughout the length of the shaft; it is generally to be used for the reception of glass-hard steel wire. Between any given and any known isothermals, therefore, we have on the outside of the polished cylindrical surface certain clear color effects. Between the same isothermals we have also a definite annealing effect, determinable by examining the parts of the steel wires there exposed. From a comparison of these data the temper value of the oxide colors is deducible in full generality. We may add that under certain circum-

stances it may be desirable to invert the cylinder; to introduce the steel wires and the elements alternately from below, and to heat the shaft in some appropriate way at the top. Indeed it appears to us that rods bored on the gun-barrel principle would offer very satisfactory objects for accurate measurements of heat conductivity; for the advantages of measuring the (constant) temperature at any point in the interior of a narrow vertical cylindrical canal, closed above, over measuring the corresponding temperature at the mantle of the rod, are obvious at once.

WASHINGTON-PRAGUE, *January*, 1886.

(502)

# INDEX.

---

	Page.
Annealing, effects of .....	50
Carburization, effect of stress on .....	42
Cell for solution of steel .....	14
Color effect of oxidation .....	51
method adopted for studying .....	52
data for high temperature .....	52
data for low temperature .....	55
minimum temperature for .....	58
minimum temperature for perceptible oxidation .....	58
Conductivity, device for measuring .....	60
Contraction ( <i>see</i> Shrinkage).	
Cores, density of successive .....	32
theory of rare .....	50
Crucible for heating steel .....	13
Cumming-Gore, contraction phenomenon observed by .....	38
Decarburization at surface .....	33
Density, minimum superficial .....	33
Density of successive shells .....	35
Errors, evaluation of .....	43
formulae for .....	44, 48
mean values of certain .....	46, 47
due to state of surface .....	47, 48
due to imperfect cylindricality .....	48, 49
summary of probable effects of .....	50
Formulae connecting data observed .....	17, 30
Fromme, results of, for structure .....	11, 12
Galvanic solution, cell for .....	14
Gooch, F. A., aid of .....	16
Grunov, steel shaft of .....	59
Harmonic distribution of density .....	35, 42
difficulties of interpretation of .....	35
causes of difficult interpretation of, analyzed .....	38, 39
Karsten, hypothesis of temper by .....	50
Magnetization, theories of .....	11
Mass action in iron-carburized .....	42
Master tool, use of .....	14
Matthiessen-Hockin, use of measurement method of .....	20
Oxidation ( <i>see</i> Color effect of oxidation).	
Oxide films .....	58
Quenching, apparatus for .....	13, 14
Resistance, method of measurement and data .....	28, 29
comparison of, at different depths .....	43
deductions from, to indicate structure .....	43

	Page.
Rupert's drops, mechanical behavior of .....	42
Shells, density of successive .....	35
theory of dense .....	50
Shrinkage, tests for .....	31
intermittent .....	41, 42
uniform viscous .....	41, 48
Siemens, use of amperimeter of .....	15
Steel, kind of, used .....	12
Stress, effect of, in modifying carburation .....	42
Structure, importance of .....	11
true and apparent .....	31
box-within-box .....	34
conclusions respecting dependence of, on kind of steel .....	50
Suspension, method of, in density work .....	16
Table, showing Fromme's results for structure .....	12
showing strength of battery (current in ampères) .....	15
No. 1. Density of soft steel .....	16
No. 2. Density of consecutive (glass-hard) cores .....	18-22
No. 3. Density of consecutive (glass-hard) shells .....	19-23
No. 4. Density of consecutive (glass-hard) cores .....	24-26
No. 5. Density of consecutive (glass-hard) shells .....	25-27
No. 6. Resistance of consecutive (glass-hard) cores .....	29
No. 7. Resistance of consecutive hard cores and shells .....	30, 31
No. 8. Resistance tests for shrinkage .....	31
No. 9. Exhibit of errors of $R$ and $\vartheta$ .....	45
No. 10. Calculated (mean numerical) errors of $\delta$ .....	46
No. 11. Exhibit of errors of $\delta$ , first series .....	47
No. 12. Exhibit of errors of $\delta$ , second series .....	47
No. 13. Density effect of friction .....	48
No. 14. Effects possibly due to shrinkage .....	48
No. 15. Consecutive positions of the color bands .....	53
No. 16. Successive distributions of temperature .....	53
No. 17. Distribution of temperature (mean values) .....	54
No. 18. Average temperature of successive color bands .....	54
No. 19. Consecutive positions of the color bands .....	56
No. 20. Successive distributions of temperature .....	56
No. 21. Distribution of temperature (mean values) .....	57
No. 22. Average temperature of the successive color bands .....	57

## ADVERTISEMENT.

[Bulletin No. 36.]

The publications of the United States Geological Survey are issued in accordance with the statute approved March 3, 1870, which declares that—

“The publications of the Geological Survey shall consist of the annual report of operations, geological and economic maps illustrating the resources and classification of the lands, and reports upon general and economic geology and paleontology. The annual report of operations of the Geological Survey shall accompany the annual report of the Secretary of the Interior. All special memoirs and reports of said Survey shall be issued in uniform quarto series if deemed necessary by the Director, but otherwise in ordinary octavos. Three thousand copies of each shall be published for scientific exchanges and for sale at the price of publication; and all literary and cartographic materials received in exchange shall be the property of the United States and form a part of the library of the organization: And the money resulting from the sale of such publications shall be covered into the Treasury of the United States.”

On July 7, 1882, the following joint resolution, referring to all Government publications, was passed by Congress:

“That whenever any document or report shall be ordered printed by Congress, there shall be printed, in addition to the number in each case stated, the ‘usual number’ (1,900) of copies for binding and distribution among those entitled to receive them.”

Except in those cases in which an extra number of any publication has been supplied to the Survey by special resolution of Congress or has been ordered by the Secretary of the Interior, this Office has no copies for gratuitous distribution.

### ANNUAL REPORTS.

Of the Annual Reports there have been already published:

I. First Annual Report to the Hon. Carl Schurz, by Clarence King. 1880. 8°. 79 pp. 1 map.—A preliminary report describing plan of organization and publications.

II. Report of the Director of the United States Geological Survey for 1880-'81, by J. W. Powell. 1882. 8°. 1v, 586 pp. 61 pl. 1 map.

III. Third Annual Report of the United States Geological Survey, 1881-'82, by J. W. Powell. 1883. 8°. xviii, 564 pp. 67 pl. and maps.

IV. Fourth Annual Report of the United States Geological Survey, 1882-'83, by J. W. Powell. 1884. 8°. xxxii, 473 pp. 85 pl. and maps.

V. Fifth Annual Report of the United States Geological Survey, 1883-'84, by J. W. Powell. 1885. 8°. xxxvi, 469 pp. 58 pl. and maps.

The Sixth and Seventh Annual Reports are in press.

### MONOGRAPHS.

Of the Monographs, Nos. II, III, IV, V, VI, VII, VIII, IX, X, and XI are now published, viz:

II. Tertiary History of the Grand Cañon District, with atlas, by Clarence E. Dutton, Capt. U. S. A. 1882. 4°. xiv, 264 pp. 42 pl. and atlas of 24 sheets folio. Price \$10.12.

III. Geology of the Comstock Lode and the Washoe District, with atlas, by George F. Becker. 1882. 4°. xv, 422 pp. 7 pl. and atlas of 21 sheets folio. Price \$11.

IV. Comstock Mining and Miners, by Eliot Lord. 1883. 4°. xiv, 451 pp. 3 pl. Price \$1.50.

V. Copper-bearing Rocks of Lake Superior, by Roland D. Irving. 1883. 4°. xvi, 464 pp. 15 l. 29 pl. Price \$1.85.

VI. Contributions to the Knowledge of the Older Mesozoic Flora of Virginia, by Wm. M. Fontaine. 1883. 4°. xi, 144 pp. 54 l. 54 pl. Price \$1.05.

VII. Silver-Lead Deposits of Eureka, Nevada, by Joseph S. Curtis. 1884. 4°. xiii, 200 pp. 16 pl. Price \$1.20.

VIII. Paleontology of the Eureka District, by Charles D. Walcott. 1884. 4°. xiii, 298 pp. 24 l. 24 pl. Price \$1.10.

IX. Brachiopoda and Lamellibranchiata of the Raritan Clays and Greensand Marls of New Jersey, by Robert P. Whitfield. 1885. 4°. xx, 338 pp. 35 pl. Price \$1.15.

X. Dinocerata. A Monograph of an Extinct Order of Gigantic Mammals, by Othniel Charles Marsh. 1885. 4°. xviii, 243 pp. 56 l. 56 pl. Price \$2.70.

XI. Geological History of Lake Lahontan, a Quaternary Lake of Northwestern Nevada, by Israel Cook Russell. 1885. 4°. xiv, 288 pp. 46 pl. Price \$1.75.

## ADVERTISEMENT.

The following is in press, viz:

XII. Geology and Mining Industry of Leadville, with atlas, by S. F. Emmons. 1886. 4°. xxix, 770 pp. 45 pl. and atlas of 35 sheets folio.

The following are in preparation, viz:

I. The Precious Metals, by Clarence King.

— Gasteropoda of the New Jersey Cretaceous and Eocene Marls, by R. P. Whitfield.

— Geology of the Eureka Mining District, Nevada, with atlas, by Arnold Hague.

— Lake Bonneville, by G. K. Gilbert.

— Sauropoda, by Prof. O. C. Marsh.

— Stegosauria, by Prof. O. C. Marsh.

— Brontotheridæ, by Prof. O. C. Marsh.

— Geology of the Quicksilver Deposits of the Pacific Slope, with atlas, by George F. Becker.

— The Penokee-Gogebic Iron-Bearing Series of North Wisconsin and Michigan, by Roland D. Irving.

— Younger Mesozoic Flora of Virginia, by William M. Fontaine.

— Description of New Fossil Plants from the Dakota Group, by Leo Lesquereux.

— Report on the Denver Coal Basin, by S. F. Emmons.

— Report on Ten-Mile Mining District, Colorado, by S. F. Emmons.

— Report on Silver Cliff Mining District, by S. F. Emmons.

— Flora of the Dakota Group, by J. S. Newberry.

## BULLETINS.

The Bulletins of the Survey will contain such papers relating to the general purpose of its work as do not properly come under the heads of Annual Reports or Monographs.

Each of these Bulletins contains but one paper and is complete in itself. They are, however, numbered in a continuous series, and may be united into volumes of convenient size. To facilitate this, each Bulletin has two paginations, one proper to itself and another which belongs to it as part of the volume.

Of this series of Bulletins Nos. 1 to 36 are already published, viz:

1. On Hypersthene-Andesite and on Triclinic Pyroxene in Augitic Rocks, by Whitman Cross, with a Geological Sketch of Buffalo Peaks, Colorado, by S. F. Emmons. 1883. 8°. 42 pp. 2 pl. Price 10 cents.
2. Gold and Silver Conversion Tables, giving the coining values of troy ounces of fine metal, etc., by Albert Williams, jr. 1883. 8°. 8 pp. Price 5 cents.
3. On the Fossil Faunas of the Upper Devonian, along the meridian of 76° 30', from Tompkins County, New York, to Bradford County, Pennsylvania, by Henry S. Williams. 1884. 8°. 36 pp. Price 5 cents.
4. On Mesozoic Fossils, by Charles A. White. 1884. 8°. 36 pp. 9 pl. Price 5 cents.
5. A Dictionary of Altitudes in the United States, compiled by Henry Gannett. 1884. 8°. 325 pp. Price 20 cents.
6. Elevations in the Dominion of Canada, by J. W. Spencer. 1884. 8°. 43 pp. Price 5 cents.
7. *Mapoteca Geologica Americana*. A catalogue of geological maps of America (North and South), 1752-1881, by Jules Marcou and John Belknap Marcou. 1884. 8°. 184 pp. Price 10 cents.
8. On Secondary Enlargements of Mineral Fragments in Certain Rocks, by R. D. Irving and C. R. Van Hise. 1884. 8°. 56 pp. 6 pl. Price 10 cents.
9. Report of work done in the Washington Laboratory during the fiscal year 1883-'84. F. W. Clarke, chief chemist; T. M. Chatard, assistant. 1884. 8°. 40 pp. Price 5 cents.
10. On the Cambrian Faunas of North America. Preliminary studies, by Charles D. Walcott. 1884. 8°. 74 pp. 10 pl. Price 5 cents.
11. On the Quaternary and Recent Mollusca of the Great Basin; with Descriptions of New Forms, by R. Ellsworth Call; introduced by a sketch of the Quaternary Lakes of the Great Basin, by G. K. Gilbert. 1884. 8°. 66 pp. 6 pl. Price 5 cents.
12. A Crystallographic Study of the Thimolite of Lake Lahontan, by Edward S. Dana. 1884. 8°. 34 pp. 3 pl. Price 5 cents.
13. Boundaries of the United States and of the several States and Territories, by Henry Gannett, 1885. 8°. 135 pp. Price 10 cents.
14. The Electrical and Magnetic Properties of the Iron-Carburets, by Carl Barus and Vincent Strouhal. 1885. 8°. 238 pp. Price 15 cents.
15. On the Mesozoic and Cenozoic Paleontology of California, by Charles A. White. 1885. 8°. 33 pp. Price 5 cents.
16. On the higher Devonian Faunas of Ontario County, New York, by John M. Clarke. 1885. 8°. 86 pp. 3 pl. Price 5 cents.
17. On the Development of Crystallization in the Igneous Rocks of Washoe, Nevada, by Arnold Hague and Joseph P. Iddings. 1885. 8°. 44 pp. Price 5 cents.
18. On Marine Eocene, Fresh-water Miocene, and other Fossil Mollusca of Western North America, by Charles A. White. 1885. 8°. 26 pp. 3 pl. Price 5 cents.
19. Notes on the Stratigraphy of California, by George F. Becker. 1885. 8°. 28 pp. Price 5 cents.
20. Contributions to the Mineralogy of the Rocky Mountains, by Whitman Cross and W. F. Hillebrand. 1885. 8°. 114 pp. 1 pl. Price 10 cents.

## ADVERTISEMENT.

21. *The Lignites of the Great Sioux Reservation*, by Bailey Willis. 1885. 8°. 16 pp. 5 pl. Price 5 cents.
  22. *On New Cretaceous Fossils from California*, by Charles A. White. 1885. 8°. 25 pp. 5 pl. Price 5 cents.
  23. *Observations on the Junction between the Eastern Sandstone and the Keweenaw Series on Keweenaw Point, Lake Superior*, by R. D. Irving and T. C. Chamberlin. 1885. 8°. 124 pp. 17 pl. Price 15 cents.
  24. *List of Marine Mollusca, comprising the Quaternary fossils and recent forms from American localities between Cape Hatteras and Cape Roque, including the Bermudas*, by William H. Dall. 1885. 8°. 336 pp. Price 25 cents.
  25. *The Present Technical Condition of the Steel Industry of the United States*, by Phineas Barnes. 1885. 8°. 85 pp. Price 10 cents.
  26. *Copper Smelting*, by Henry M. Howe. 1885. 8°. 107 pp. Price 10 cents.
  27. *Report of work done in the division of Chemistry and Physics, mainly during the fiscal year 1884-'85*. 1886. 8°. 80 pp. Price 10 cents.
  28. *The Gabbros and Associated Hornblende Rocks occurring in the neighborhood of Baltimore, Md.*, by George H. Williams. 1886. 8°. 78 pp. 4 pl. Price 10 cents.
  29. *On the Fresh-water Invertebrates of the North American Jurassic*, by Charles A. White. 1886. 8°. 41 pp. 4 pl. Price 5 cents.
  30. *Second contribution to the studies on the Cambrian Faunas of North America*, by Charles D. Walcott. 1886. 8°. 369 pp. 33 pl. Price 25 cents.
  31. *A systematic review of our present knowledge of Fossil Insects, including Myriapods and Arachnids*, by Samuel H. Scudder. 1886. 8°. 128 pp. Price 15 cents.
  32. *Lists and Analyses of the Mineral Springs of the United States; a preliminary study*, by Albert C. Peale. 1886. 8°. 235 pp. Price 20 cents.
  33. *Notes on the Geology of Northern California*, by Joseph S. Diller. 1886. 8°. 23 pp. Price 5 cents.
  34. *On the relation of the Laramie Molluscan Fauna to that of the succeeding Fresh-water Eocene and other groups*, by Charles A. White. 1886. 8°. 54 pp. 5 pl. Price 10 cents.
  35. *The Physical Properties of the Iron-Carburets*, by Carl Barus and Vincent Strouhal. 1886. 8°. 62 pp. Price 10 cents.
  36. *Subsidence of fine Solid particles in Liquids*, by Carl Barus. 1887. 8°. 58 pp. Price 10 cents. Numbers 1 to 6 of the *Bulletins* form Volume I; Numbers 7 to 14, Volume II; Numbers 15 to 23, Volume III; Numbers 24 to 30, Volume IV; Numbers 31 to 36, Volume V; Volume VI is not yet complete.
- The following are in press, viz:
37. *Types of the Laramie Flora*, by Lester F. Ward.
  38. *Peridotite of Elliott County, Kentucky*, by Joseph S. Diller.
  39. *The Upper Beaches and Deltas of the Glacial Lake Agassiz*, by Warren Upham.
- In preparation:
40. *Changes in River Courses in Washington Territory due to Glaciation*, by Bailey Willis.
  41. *Fossil Faunas of the Upper Devonian—the Genesee Section*, by Henry S. Williams.
  42. *Report of work done in the division of Chemistry and Physics, mainly during the fiscal year 1885-'86*. F. W. Clarke, chief chemist.
  43. *On the Tertiary and Cretaceous Strata of the Tuscaloosa, Tombigbee, and Alabama Rivers*, by Eugene A. Smith and Lawrence C. Johnson.
  44. *Historic statement respecting geologic work in Texas*, by R. T. Hill.
  45. *The Nature and Origin of Deposits of Phosphates of Lime*, by R. A. F. Penrose, jr.
  46. *Bibliography of North American Crustacea*, by A. W. Vogdes.

### STATISTICAL PAPERS.

A fourth series of publications, having special reference to the mineral resources of the United States, has been undertaken.

Of that series the following have been published, viz:

1. *Mineral Resources of the United States [1882]*, by Albert Williams, jr. 1883. 8°. xvii, 813 pp. Price 50 cents.
2. *Mineral Resources of the United States, 1883 and 1884*, by Albert Williams, jr. 1885. 8°. xiv, 1010 pp. Price 60 cents.
3. *Mineral Resources of the United States, 1885*. Division of Mining Statistics and Technology. 1886. 8°. vii, 576 pp. Price 40 cents.

Correspondence relating to the publications of the Survey, and all remittances, which must be by POSTAL NOTE or MONEY ORDER (not stamps), should be addressed

TO THE DIRECTOR OF THE

UNITED STATES GEOLOGICAL SURVEY,

WASHINGTON, D. C.

WASHINGTON, D. C., *March 1, 1887.*