

# Collecting Peak-Flow Data in Ohio Through the Use of Crest-Stage Gages

## Importance of peak-flow data

Throughout Ohio's history, floods have caused serious damage to private property, public buildings, and highways and have posed a risk of personal injury and death. Flood magnitude and frequency data, which are crucial for flood-related planning and emergency response, are not usually available for many of the smaller streams in Ohio, especially streams with drainage areas less than 100 square miles. Future statewide flood-frequency analyses would provide more complete and accurate peak-flow estimates if sufficient peak-flow data could be included for additional small streams. More accurate estimates of peak flow would then enable agencies responsible for designing hydraulic structures, bridges, and culverts to accomplish this more economically and efficiently.

The method to determine the magnitude and frequency of peak-flow data on streams is to systematically collect data for a period of at least 10 years at sites where no flood data are currently available. These peak-flow data can then be incorporated into a regional flood-frequency analysis. Because only peak flow data are needed, the operation of a continuously-recording streamflow-gaging station to collect those data would be relatively expensive and unnecessary. Instead, crest-stage gages, which record only peak flows, can be used to collect these data in an efficient and cost-effective manner.

Six of the gage sites were selected on streams with drainage areas less than 7 square miles, with a culvert suitable for developing a theoretical rating that relates gage height of the stream to streamflow. This rating is based on the hydraulic characteristics of the surveyed approach channel and the culvert opening itself.

Six other gage sites were selected on streams with drainage areas between 5 and 45 square miles, with channels and bridge openings suitable for a theoretical open-channel rating. The step-backwater analysis technique is being used to define the theoretical rating, and streamflow measurements will be made to check or modify the rating.

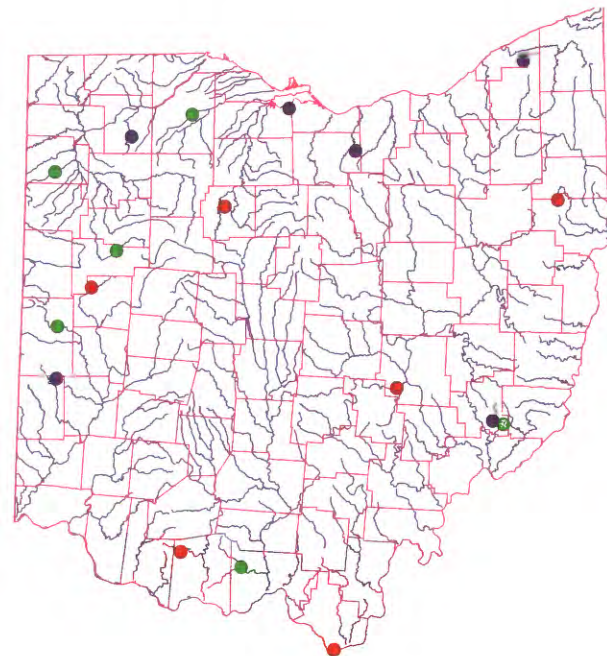

### EXPLANATION

- Small sites at culverts (0-7 square miles)
- Medium sites at bridges (5-45 square miles)
- Large sites at bridges (45-100 square miles)
- Counties
- Streams

## The Ohio crest-stage gage network

The Ohio crest-stage gage network, operated by the U.S. Geological Survey in cooperation with the Ohio Departments of Transportation and Natural Resources, consists of 18 crest-stage gage sites with drainage areas less than 100 square miles (fig. 1), located throughout Ohio where peak-flow data were either minimal or nonexistent. Gages at these sites were installed prior to October 2001, when data collection began.

Figure 1. The Ohio crest-stage gage network.



The final six gage sites were selected on streams with larger drainage areas between 45 and 100 square miles, with channels and bridge openings that might not be as suitable for a theoretical open-channel rating. The ratings for these sites will be developed and defined by making several high-streamflow measurements with associated stage measurements each year (the same method that is used for most gaging stations). For these sites, only the middle and upper part of the rating needs to be defined because only flood peaks will be recorded by the gages.

### Crest-stage gage design

The crest stage gage (figs. 2 and 3) is a remarkably simple, but valuable, device and is being used at all sites regardless of how the rating is defined. Each crest-stage gage is strategically located along a streambank to record all ranges of peak flows. During high flows, water enters the pipe and rises to the level of the flood crest (peak). Granulated cork, which is retained in the bottom of the pipe, floats on the rising water and is deposited on the wood recording stick inside the pipe, leaving a distinct eleva-

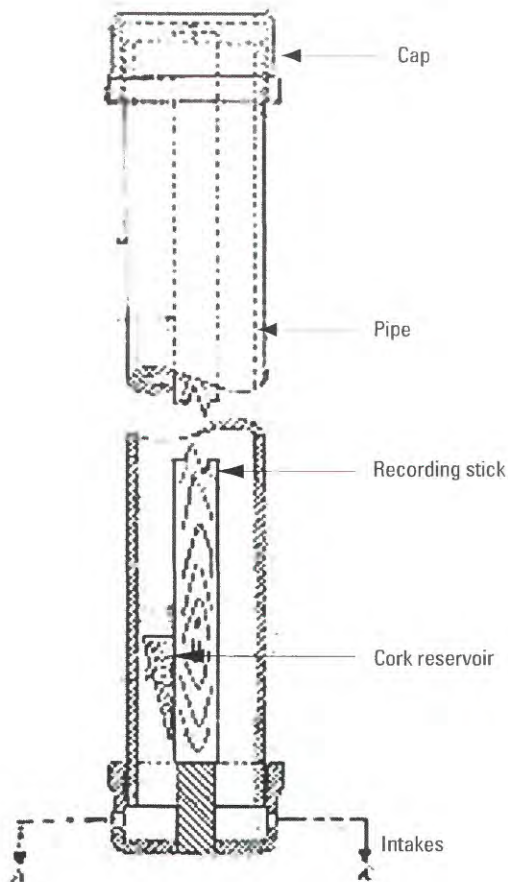

Figure 2. Diagram of typical crest-stage gage design.

tion mark. When the gage is serviced, at least once every 2 months, the height of the mark on the stick is measured and recorded, and this elevation is then used in calculations to develop the rating for the site.

At the end of each water year, the peak level that was recorded at each of the sites is determined, and the maximum stage and associated streamflow for the year are published in the USGS annual Water-Data Report for Ohio.



Figure 3. Photo of typical crest-stage gages. All sites have at least two pipes, one upstream and one downstream from the structure (bridge or culvert). Most sites have more pipes to cover the range of stages possible.

### Additional information

For additional information about the USGS crest-stage gage network, contact:

Bernie Sroka  
 U.S. Geological Survey  
 6480 Doubletree Avenue  
 Columbus, OH 43229-1111  
 E-mail: [bnsroka@usgs.gov](mailto:bnsroka@usgs.gov)  
 Phone: (614) 430-7779  
 Fax: (614) 430-7777