

(200)  
R290  
no. 1627

Interagency Report  
Military - 2

UNITED STATES  
DEPARTMENT OF THE INTERIOR  
GEOLOGICAL SURVEY

✓ U. S. Geological Survey  
OPEN FILE REPORT  
This report is preliminary and has  
not been edited or reviewed for  
conformity with Geological Survey  
standards or nomenclature.

ENVIRONMENTS AT U. S. AND U.S.S.R. NUCLEAR EXPLOSION SITES:  
PETROLEUM-STIMULATION PROJECTS

By

Maurice J. Terman

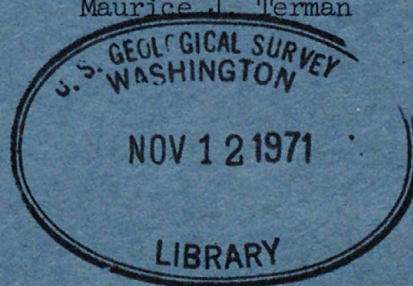

Sponsored by

ADVANCED RESEARCH PROJECTS AGENCY  
ARPA ORDER NO. 1626

WASHINGTON, D. C.  
1970

This report has not been edited or reviewed for conformance  
with the U. S. Geological Survey standards

(200)  
R290  
no. 1627

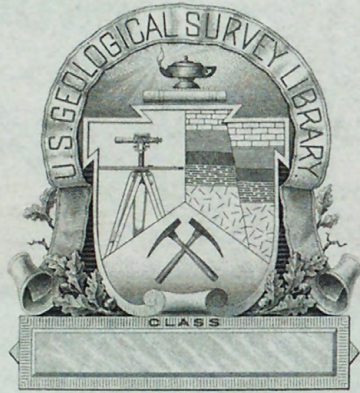

2007  
R290  
no. 1627

Interagency Report  
Military - 2

UNITED STATES

DEPARTMENT OF THE INTERIOR

4.5 GEOLOGICAL SURVEY

[Reports - Open file series]



# U. S. GEOLOGICAL SURVEY OPEN FILE REPORT

ENVIRONMENTS AT U. S. AND U.S.S.R. NUCLEAR EXPLOSION SITES:  
PETROLEUM-STIMULATION PROJECTS

sl  
um

By

Maurice J. Terman

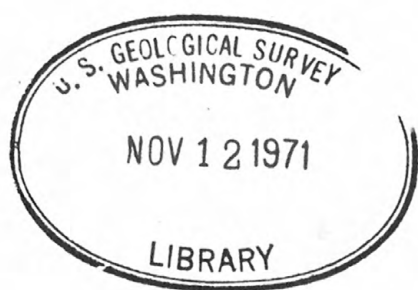

Sponsored by

ADVANCED RESEARCH PROJECTS AGENCY  
ARPA ORDER NO. 1626

231394

WASHINGTON, D. C.  
1970

This report has not been edited or reviewed for conformance  
with the U. S. Geological Survey standards

(200)

R290

no 1627

Weld - Int. 2905

✓  
U.S. GEOLOGICAL SURVEY  
WASHINGTON, D.C.

20242

[Reports - Open file series]

For release OCTOBER 27, 1971

The U.S. Geological Survey is releasing in open file the following reports. Copies are available for inspection in the Geological Survey Libraries, 1033 GS Bldg., Washington, D.C. 20242; Bldg. 25, Federal Center, Denver, Colo. 80225; and 345 Middlefield Rd., Menlo Park, Calif. 94025. Copies are also available for inspection at other offices as listed:

1. Geologic map of the Ishpeming quadrangle, Marquette County, Michigan, by George C. Simmons. 1 sheet, scale 1:62,500. Michigan Dept. of Natural Resources, Geol. Survey Div., Stevens T. Mason Bldg., Lansing, Mich. 48926. [Material from which copy can be made at private expense is available in the Lansing, Mich., office listed above.]
2. Environments at U.S. and U.S.S.R. nuclear explosion sites: petroleum-stimulation projects, by Maurice J. Terman. 62 p., 25 figs., 8 tables.

\* \* \*



## CONTENTS

	<u>Page</u>
INTRODUCTION . . . . .	1
NEED FOR PETROLEUM STIMULATION . . . . .	3
UNITED STATES GAS-STIMULATION PROJECTS . . . . .	3
Fracturing . . . . .	4
Effect on reservoir permeability . . . . .	8
Effect on reservoir geometry . . . . .	11
Heating . . . . .	11
Radioactivity . . . . .	13
Seismicity . . . . .	16
Economics . . . . .	18
Public opinion . . . . .	19
U.S.S.R. PETROLEUM-INTENSIFICATION PROJECTS . . . . .	19
Fracturing . . . . .	20
Effect on reservoir permeability . . . . .	21
Effect on reservoir geometry . . . . .	22
Heating . . . . .	23
Radioactivity . . . . .	23
Seismicity . . . . .	24
Economics . . . . .	24
SUMMARY . . . . .	25
REFERENCES . . . . .	27

## ILLUSTRATIONS

- Figure 1. Underground nuclear explosion phenomenology
2. Relationships of yield, depth, cavity radius, and volume in granite
3. Effect of rock mechanics on underground nuclear explosions
4. Plots of parametric values for explosion phenomena in petroleum reservoir rocks
5. Behavior of reservoir rock samples subject to nuclear explosion
6. Peak stress for underground nuclear explosions
7. In situ permeability of Hardhat chimney wall rock
8. Permeability distribution at explosion sites
9. Effects of reservoir permeability and device yield on ultimate recovery
10. Core permeability and petroleum-stimulation project sites
11. Production history of the Gasbuggy site
12. Reservoir geometry and petroleum-stimulation amenability
13. Heating effects of contained nuclear explosions
14. Petroleum stimulation by heating
15. Yield-mass curve for thermal fission of  $U^{235}$
16. Radioactivity and time after detonation
17. Predicted peak surface particle motion versus slant distance
18. Projected charges for thermal nuclear explosives
19. Subsurface geology of experimental oilfield site
20. Cross-sections of experimental oilfield site

21. Subsurface geology of gasfield project site - Scheme I
22. Cross-sections of gasfield project site - Scheme I
23. Subsurface geology of water-drive oilfield project site -  
Scheme II
24. Production history of water-drive oilfield project site -  
Scheme II
25. Three-dimensional comparison of petroleum-stimulation  
projects

## TABLES

- Table 1. Environmental data at U. S. sites for petroleum-stimulation Plowshare projects
2. Contained nuclear explosions in typical petroleum reservoir rocks
  3. Suggested parametric values for explosion phenomena in selected petroleum reservoir rocks
  4. Behavior of reservoir rock samples subjected to nuclear explosion
  5. Long-lived radionuclides significant in petroleum-stimulation projects
  6. Costs in the Rulison project area
  7. Environmental data at U.S.S.R. sites for petroleum-intensification projects
  8. Extent of fracturing indicated in Soviet sources

## INTRODUCTION

The United States Plowshare program for the peaceful application of nuclear explosives was formally established by the Atomic Energy Commission in 1957. A number of engineering uses for such explosions were proposed and discussed in the late fifties, mostly by personnel of the Lawrence Radiation Laboratory under contract to AEC, and several projects were studied in detail during the nuclear weapons test moratorium extending from the fall of 1958 to the fall of 1961. The first Plowshare experiment, Project Gnome, was detonated on December 10, 1961. Since that time phenomenological data have been obtained in many media, including alluvium, tuff, shale, dolomite, salt, basalt, and granite, with explosions at depths ranging from near the surface to about 2,500 meters. After negotiation between El Paso Natural Gas Company and AEC, the first joint industry-government Plowshare experiment, Project Gasbuggy, was detonated on December 10, 1967. The second such experiment, Project Rulison, conducted on September 10, 1969, under the sponsorship of Austral Oil Company, Inc., the AEC, and the Department of Interior, is currently being evaluated. These two experiments emphasized the U. S. interest in the potential application of underground nuclear explosions to the petroleum industry, especially to gas stimulation in sizable regions of large-scale, low productivity, generally undeveloped resources. (Petroleum as used in this report refers to both gas and oil resources.)

The Union of Soviet Socialist Republics has evinced considerable interest in the nonmilitary applications of nuclear energy, but their parallel development of research and experimentation has largely gone unpublicized. The true extent of their progress has been indicated at the Soviet-American technical talks on the use of nuclear explosions for peaceful purposes which were held in Vienna during April 1969 and in Moscow during February 1970. The Soviets identified cratering and underground projects in a number of media, including clay, shale, sandstone, limestone, salt, and granite, with explosions at depths ranging from near surface to about 1,500 meters. All of the identified underground projects have had industrial applications, as follows:

- a series of three explosions (two events) as a secondary-recovery project in an experimental oilfield;
- single explosions at two sites to control wild gas wells;
- single explosions at two sites in one salt structure to create storage cavities; and
- an unevaluated gas-stimulation project.

These experiments also emphasize the primary U.S.S.R. interest in the potential application of underground nuclear explosions to the petroleum industry.

This paper proposes to bring together widely scattered data pertaining to all known petroleum-stimulation projects, particularly detailing the environments at such sites. The work has been sponsored by the Advanced Research Projects Agency and monitored by Verne C. Fryklund, Jr. Great appreciation is expressed for the considerable help in the research and preparation of the final report that has been offered by my associates in the U. S. Geological Survey, by J. Wade Watkins and personnel of the Division of Petroleum and Natural Gas, U. S. Bureau of Mines, and by Richard Hamburger and personnel of the Division of Peaceful Nuclear Explosions, U. S. Atomic Energy Commission.

## NEED FOR PETROLEUM STIMULATION

The petroleum industry has investigated numerous techniques for applying energy to reservoir rocks in attempts to stimulate production and increase the percentage of recovery. The rate of flow of a fluid to a well is directly proportional to the reservoir permeability and thickness, fluid density, and the difference in the static reservoir pressure and flowing wellbore pressure. The rate is inversely proportional to fluid viscosity, compressibility, and the logarithm of the ratio of the drainage radius to wellbore radius. Therefore, an increase in rate of flow can be achieved by introduction of additional fluids (flooding, etc.) to increase reservoir pressure, by "treating" the reservoir rocks to increase permeability and the effective radius of the wellbore, or by heating the petroleum to lower its viscosity. "Treatments" traditionally range from acidizing carbonate reservoirs to fracturing clastic reservoirs; fracturing originally was accomplished by shooting with solidified nitroglycerin, and more recently by hydraulic fracturing where water and sand are pumped into the reservoir under pressure sufficient to produce a fracture that is then held open by the injected sand grains. Maximum initial increase in production is approximately fivefold by shooting and tenfold by hydraulic fracturing, but experience shows that these rates subsequently decline. The petroleum industry the world around obviously recognizes the potential of underground nuclear explosions as local energy sources for possible stimulation of production and increasing ultimate recovery percentages.

### UNITED STATES GAS-STIMULATION PROJECTS

Underground nuclear explosion phenomenology is documented from the more than 200 tests (U. S. Atomic Energy Commission, 1969a) since the detonation of the 1.7-kiloton Rainier explosion in September 1957. Sequential schematic diagrams of this phenomenology, based on data from the Gasbuggy Project, are shown in Figure 1. The exploratory and emplacement work culminates with an explosion which creates a spherical cavity by vaporizing the enclosing rock at extremely high temperatures and pressures (over ten million degrees and one million atmospheres), and generates extremely strong compressional shock waves (fig. 1a). The cavity expands until the gas pressure equals the lithostatic pressure (approximately 230 g/cm<sup>2</sup> for each meter of depth) as shock waves continue to transmit energy into the surrounding rock, initiating within it an extensive and intricate network of fractures (fig. 1b). Within the cavity, the rock vapor condenses and the melt runs down the sides to collect in a puddle on the floor (fig. 1c). A few seconds to minutes, rarely hours or days, after the explosion, the cavity pressure falls below a critical value and the fractured roof rock normally starts to collapse into the cavity, and, within a few seconds, a large generally cylindrical chimney of broken rock develops upward towards the surface

until the rounded roof rock becomes strong enough to support itself or until bulky broken rock fills the void and supports the roof (fig. 1d). Considering this phenomenology, the physical effects that need to be considered in relation to petroleum-stimulation projects are fracturing, heating, radioactivity, and seismicity.

The American philosophic position and technical criteria applicable to stimulation were investigated and well defined by Atkinson and Johansen in 1964. They concluded that production increases caused by the fracturing of thick, low permeability, natural gas reservoirs at moderate depths appear to be technically and economically feasible and potentially capable of raising submarginal resources to commercial levels, whereas production increases caused by the heating of oil reservoirs appear to be disappointingly small and unpromising. Considerable subsequent empirical data and several ongoing and proposed Plowshare projects all tend to substantiate these conclusions. The environmental data for these United States projects are summarized in Table 1. The current state of knowledge suggests the following discussion of the specific effects of underground nuclear explosions as related to gas-stimulation projects.

### Fracturing

The spatial relationships of broken and displaced rock created by contained explosions have recently been reviewed by Boardman (1970); his data involving only typical hydrocarbon reservoir rocks, sedimentary carbonates and fine-grained clastics, are presented in Table 2. (Notations and the metric units used throughout this paper are also defined in this table). The following characteristics pertaining to hydrocarbon stimulation are abstracted from Boardman's excellent review unless otherwise noted.

- $R_c$  The basic parameter from which all others are derived is the cavity radius. The radius of vaporization is estimated at about 2 meters for a 1-kt explosion but the final cavity size exceeds such a scaled value because of additional melting and mechanical effects. Higgins and Butkovich (1967) developed a definitive scaling equation:

$$R_c = \frac{C W^{1/3}}{(\rho h)^\alpha} \quad (1)$$

where C, the lithology constant, has been determined in 46 nuclear events to approximate 89 for alluvium (30 events) and dolomite (1), 96 for salt (2), 97 for tuff (11), and 103 for granite (2); W is the yield in kilotons;  $\rho$  is the overburden density in g/cc; h is the depth of burial; and  $\alpha$ , the adiabatic expansion coefficient, varies with the water content from about 0.25 to 0.33. Figure 2 shows the relationships of yield, depth, and cavity radius for a

granite medium. For shallow (less than 600 meters) contained explosions, the simple cube-root energy scaling equation (Boardman, 1970) appears adequate:

$$R_c = C_c W^{1/3} \quad (2)$$

where  $C_c$ , the lithologic cavity constant, approximates 9 for carbonate rocks, 11.5 for granite, 12.3 for salt, 13 for clastic rocks and has theoretical values as high as 15. The greater the depth of the shot point, the smaller the cavity because of the greater lithostatic load. The effect of different lithologies and depth on final configurations is shown in Figure 3.

$R_{ch}$  The chimney radius is assumed to approximate the cavity radius, but some overbreak is expectable along the shattered chimney walls; measurements at various distances above the shot point (56.5 meters in the Handcar chimney) have been made for three projects, averaging:

$$R_{ch} = 1.1 R_c \quad (3)$$

$H_{ch}$  The chimney height in eleven projects has the following relationship:

$$H_{ch} = C_{ch} R_c \quad (4)$$

where  $C_{ch}$ , the lithologic chimney constant, statistically averages 4.4 and ranges from 3.2 to 6.2; a few reasonable assumptions based on local geologic variability at the sites narrow the variability, suggesting a value of  $5.7 \pm 0.6$  with a practical upper limit of between 6 and 7.

$V_{ch}$  The bulking characteristics of the different rocks create different percentages of voids in the various chimneys; 25 percent porosity appears to be an expectable value in most reservoir rocks. The void volume of both the initial cavity and the final chimney is directly related to yield:

$$V_c = C_v W \quad (5)$$

where  $C_v$ , the lithologic void constant, averages 3 for the reservoir rocks and as high as 6.2 for granites. As with the cavity radius, lower values can be expected at greater depths. The rubble volume within the final chimney has been even more highly variable in past projects, but this would have much less effect on a petroleum stimulation exercise than the particle size distribution of the rubble.

The data from the Handcar project, derived from downhole photographs in dolomite rock, indicate: few of the fragments were larger than 1 m or smaller than 10 cm in diameter; 65 percent were less than 30 cm and 80 percent were more than 15 cm in diameter; and the median particle size was between 20 and 25 cm. Rabb (1970) estimates from Piledriver data that the typical particle-size distribution for hard rock would be approximately 80 percent less than 1 m with the median about 30 cm and the bulk of the particles (65-75 percent) between 3 and 90 cm. There should be considerable differences between rock types and within a few meters in one rock type, but the combination of very few large boulders and almost no fines is favorable for fluid or gaseous movement.

$R_f$  At some of the early explosion sites, observations of lateral fracturing indicated a simple cube-root energy scaling equation for the calculation of the radius of fracture:

$$R_f = 40 W^{1/3} \quad (6)$$

At one of the sites studied most intensively, the French Hoggar test site in Algeria, Derlich (1970) gives the fracture zone radius in granite as  $26 W^{1/3}$ . Atkinson and Johansen (1964) suggested that the preexisting planes of weakness in most reservoir rocks would permit a new fracture pattern to extend farther, and thus estimated:

$$R_f = 65 W^{1/3} \quad (7)$$

By substitution from equation (2) and using 9 for the lithologic constant, these equations indicate that the radius of fracture would be about  $4.5 R_c$ ,  $2.9 R_c$ , and  $7.2 R_c$  respectively. All current discussions recognize, however, that the volume of fractured rock is not spherical but more nearly cylindrical, as follows:

$H_f$  The height that explosion-induced fractures extend above a shot point has been estimated as

$$H_f = (7 \pm 1) R_c \quad (8)$$

This is supported by the Handcar data and is indicated at the Gasbuggy site by casing disruptions at scaled distances of  $5.2 R_c$  and  $7.2 R_c$ . In three tests in granitic rocks, the values ranged from 6.9 to  $7.6 R_c$ .

$D_f$  The depth of fractures below a shot point has not been generally observed, but for sometime has been estimated at

$$D_f = 1.5 R_c \quad (9)$$

However, recent data from the Gasbuggy site (Holzer, 1970) indicate that the extent of fractures below the shot point would be quite similar to the extent of lateral fractures as cited below.

$L_f$  The lateral extent of fractures from a shot point has been estimated as

$$L_f = (3 \pm 0.5) R_c \quad (10)$$

Observations of movement in preexisting openings indicate fractures extend to  $5 R_c$  at the Shoal site and to  $6 R_c$  at the Hardhat site, but such movements may be due to interface reaction with shock waves and may not reflect the true extent of continuous fractures; more data are needed to clarify these field relationships.

$V_f$  The minimum volume of the rock mass that is fractured might be approximated by assuming a cylindrical form and substituting from equations (8), (9), and (10):

$$V_f = 0.24 R_c^3 \quad (11)$$

if the volume is expressed in thousands of cubic meters. Assuming that the fracture pattern were spherical for a similar volume, the radius of the sphere would be

$$R_f = 3.87 R_c \quad (12)$$

This relationship appears more likely than that derived by either equations (6) or (7). Also, by substituting from equation (2), the following relationships can be derived:

$$R_f = 35 W^{1/3} \quad (13)$$

and

$$V_f = 175 W \quad (14)$$

Note that if the lithologic constant is taken at its maximum suggested value of 15, then the volume would approach  $870 W$ ; thus, the value of the lithologic constant is critical.

Precise quantitative values for these expressions cannot be derived from the existing empirical data; the additional observational facts to be derived from the Gasbuggy and Rulison projects should do much to clarify relationships.

From the above discussion, a first approximation of the parametric values for a typical oil or gas reservoir rock might be summarized as in Table 3 and Figure 4. As a lithologic constant is utilized in almost every equation, the nature of the surrounding rock is of great importance. The empirical data derived at sites in various media have been amplified by a specific experiment that was conducted as part of the Gnome project in 1961. A number of small rock samples, including clastics and carbonates, were subjected to shock pressures ranging from 3.7 to 8.4 kilobars created by the 3.1-kiloton nuclear explosion at a depth of 361 meters in bedded salt. The reservoir-rock sample behavior has been well described by Coffey and others (1964): statistical and graphical data modified from their report, comparing physical properties of shocked and unshocked samples, are presented in Table 4 and Figure 5. The visual effect of the nuclear explosion on the samples was not dramatic, producing no apparent plastic deformation; the clastics showed only slight increases in friability, but the carbonates exhibited a considerable network of macro- and micro-fractures. The porosity of the clastics showed no significant change, while that of the carbonates generally increased (fig. 5c, d). The permeability of the clastics exhibited a general decrease, while that of the carbonates increased directly with an increase in shock pressure (fig. 5a, b). The compressive strength of both major reservoir rock types generally decreased. The shock pressure also initiated both cracking and polymerization in a small percentage of the oil samples; the degree and relative proportion of change appear to be a function of the nature of the crude, and emphasize that only a small fraction of the total reservoir oils in the vicinity of a nuclear explosion would be affected. Although admitting that the number of samples were few and that the full range of explosion effects was not tested, the authors tentatively conclude from available evidence that carbonate reservoirs, and others which deform by brittle fracturing, are probably the most suitable candidates for stimulation projects.

The above phenomena are directly related to two aspects of hydrocarbon-stimulation projects in that they affect reservoir permeability and favor selection of reservoirs with given geometric relationships.

#### Effect on reservoir permeability

The nuclear explosion phenomenology described above creates and interconnects voids and thereby increases the permeability of the surrounding rocks. The permeability of the rubble in a nuclear chimney is enormous; pressurization tests indicate that it generally responds

like a leaky tank and reacts to a pressure pulse like an open cavity; thus, fluid flow should have little resistance. Rodean (Boardman, 1970) estimated the permeability value of  $4 \times 10^5$  darcies for the chimney rubble at the Hardhat site; original in situ measurements in the granite were as low as  $10^{-5}$  darcies, indicating a maximum increase approaching 10 orders of magnitude. The permeability of the rock surrounding the chimney changes because of the shock pressures exerted during the growth of the cavity. Figure 6 illustrates the data derived for peak compressive stress in different media versus scaled radius. Such pressures create changes in matrix permeability, bedding permeability, and fracture permeability -- possibly not separable in some reservoirs -- with the greatest changes resulting from the development of an intricate network of fractures. The total result of all changes has been measured either in situ or in core samples, or by noting drilling fluid losses at a number of sites; such data have been used to derive the extent of fracturing as indicated in the parametric values given in Table 3. The spatial variation in fracture permeability has been measured in detail only at the sites in granitic rock. Data from the Hardhat site given by Boardman and Skrove (1966) are shown graphically in Figure 7: immediately adjacent to and very near the chimney boundaries permeability of the shattered rock approached several darcies, which was as much as 5 orders of magnitude greater than the lowest recorded in situ measurements of several  $10^{-5}$  darcies; such higher levels of change were noted for about  $2\frac{1}{2} R_{ch}$  from the vertical axis of the chimney, and lower levels may extend as far as  $6 R_{ch}$  laterally and  $1.2 R_c$  below the shot point; and measurements of pre-shot and post-shot samples by Short (1964) indicate threefold or fourfold increases in the matrix permeability of the granitic rock (12 to 44 microdarcies) up to distances of  $1.8 R_c$ . Data from the Algerian Hoggar test site given by Delort and Supiot (1970) are shown graphically in Figure 8: the principal categories marginal to the chimney are increases of 120x to  $2.8 R_c$ , 12x to  $3.7 R_c$ , 8x to  $5 R_c$ , and 6x to  $5.8 R_c$  from the in situ permeability of 5 md. In the bedded salt deposits at the Gnome site, most of the increase in permeability is related to parting along bedding planes caused by the temporary uplift of the beds over the explosion site. Permeability distributions of the sites in granite and the Gnome site in bedded salt are presented in Figure 8 at the same scale as used previously in Figure 1 for the Gasbuggy site in a bedded clastic sequence; it is anticipated the local geologic phenomena will have considerable effect of final spatial configuration of permeability increases.

The maximum ratios of permeability values from original rock to explosion-affected rock to chimney might be on the order of 1 to  $10^5$  to  $10^{10}$ . The Gasbuggy results (Holzer, 1970) show no such dramatic changes, but indicate only a possible 100-fold increase to distances of one cavity radius. In the most common reservoir rocks, it is more likely that the magnitude of the total increase in permeability from all changes in the affected area ranges from about three-fold, as at

the Handcar site (several hundred millidarcies to 1 darcy), to about five-fold, as at the Gasbuggy site (0.01 to 0.05 md.). As much of this increase is due to micro-fracturing, the permeability changes will be most pronounced as related to increases in gas production rates rather than in oil production rates. Frank and others (1970) review the effect of different size devices on gas reservoirs with different original permeabilities (fig. 9) and predict the long range increases in ultimate recovery percentages; they indicate about a five-fold increase in ultimate recovery for Project Rulison. Atkinson and Johansen (1964) stress one major qualification to the effectiveness of this phenomena: the uncontrolled fractures produced by a nuclear explosion in a water-drive reservoir can be expected to affect ultimate recovery adversely, as significant parts of the oil reserves may be bypassed by the displacing water. Another qualification is related to the original permeability values in a reservoir rock: if it is too low, even extensive fracturing may not improve it sufficiently to create commercial production rates. A final qualification is that the maximum depth to which fractures will remain open sufficiently to assist in petroleum production is unknown.

Laboratory permeability values can be used as a guide to the amenability to stimulation of gas reservoirs, or solution-gas-drive oil reservoirs, at normal depths. Reservoir rocks range from those with extremely low values (less than 0.001 md.), where stimulation would be impracticable, to those with values commonly found in commercial fields, where stimulation would appear unnecessary. Somewhere in the intermediate values, an optimum permeability range exists in which uneconomic low productivity could be improved by explosion-induced fractures increasing permeability and productivity to a commercial level. The gas-stimulation projects in the U. S., as shown in Figure 10, indicate a current belief that this optimum value lies somewhere between core determinations of 0.1 to 1.0 millidarcies. The core determinations average about 0.15 md. at the Gasbuggy site, 0.25 md. at Wagon Wheel and WASP sites, 0.5 md. at the Rulison site, and 1.3 md. at the Dragon Trail site. However, the in situ permeability at the Gasbuggy site has been determined by other methods to be less than 0.01 md.; even if the laboratory determinations are an order of magnitude in error, they still are indicative of relative differences in the conditions at various sites.

The known interim results of the Gasbuggy project (Holzer, 1970) appear to justify the position that production from thick, low permeability, natural gas reservoirs at moderate depths can be significantly stimulated by underground nuclear explosions. The 17-month cumulative production history of gas from the reentry well, GB-ER, shown in Figure 11, emphasizes that Gasbuggy has already produced more than twice as much gas as any of five conventional wells within  $1\frac{1}{2}$  km, and flow rate extrapolations indicate a final production capability of 5 to 8 times that of any of the conventional wells.

## Effect on reservoir geometry

The magnitude of the fracture pattern of a nuclear explosion requires a minimal preferable thickness of the reservoir. Nuclear-explosion fracturing also must compete with conventional hydraulic fracturing as an effective and inexpensive stimulation method for reservoirs. A minimum net-pay thickness of about 60 meters (200 feet) was suggested by Atkinson and Johansen (1964) for economically feasible nuclear methods. Figure 12 shows that all United States projects exceed this minimum: Gasbuggy reservoir is 88.4 meters thick with 58 meters of gas-bearing sands; Dragon Trail reservoir is about 90 to 150 meters thick; and Rulison reservoir is about 760 meters thick with about 150 meters of gas-bearing sands.

The magnitude of the fracture pattern similarly requires that the nuclear device must be buried at a depth sufficient to prevent any surface venting of radioactivity. Hansen and Lombard (1964) suggest that for explosions in hard rock, venting can be prevented by a depth of burial equal to the anticipated chimney height plus a 90- to 150-meter thick "buffer" of overlying rock. Such a scaled containment depth ( $Z$  in meters) would depend primarily on the yield of the device ( $W$  in kilotons) and, to a much lesser extent, on the nature of the rock sequence, as follows:

$$Z = C_d W^{1/3} \quad (15)$$

where  $C_d$ , the lithologic depth constant, is cited usually between 108 and 145 and might safely be averaged as 120 (U. S. Atomic Energy Commission, 1969b). An arbitrary "Safe" minimum depth for reservoir rocks has been cited by Atkinson and Johansen (1964) as 300 meters (1,000 feet). Conversely, if the device is emplaced at too great a depth, the lithostatic pressure is thought by some to become sufficient to close all fractures - at least, with the passage of time - and thus diminish any original increase in the permeability. An arbitrary maximum depth for reservoir rocks has been cited by Atkinson and Johansen (1964) as about 2,500 meters (8,000 feet). Figure 12 graphically indicates that Gasbuggy and Dragon Trail specifications fall within the suggested limits, but the reservoirs for Rulison, Wagon Wheel, and WASP are mostly deeper.

## Heating

The energy released by an underground nuclear explosion is generally equivalent to  $4.185 \times 10^{19}$  ergs or  $10^{12}$  calories per kiloton (Heckman, 1964). The actual amount of energy locally deposited as residual thermal energy depends upon the degree of containment; if complete, as would be expectable for hydrocarbon-stimulation projects, 90 to 95 percent of the nuclear energy is deposited. In Figure 13,

the percentage of the total nuclear energy available as residual heat (dashed lines) is shown as a function of the minimum temperature rise produced in the first 100 milliseconds following explosions in tuff and salt. As the molten rock puddles and cools on the floor of the cavity, the thermal energy is dissipated by conduction through underlying rock fractures or overlying chimney rubble, gas convection in the chimney, and, after several months, possibly by liquid convection in the chimney. The resultant lowering of temperature produces a series of new distribution curves (solid lines) indicating that 4 to 6 months after an explosion the maximum observed temperature for contained shots is generally between 80° and 90°C, and that abnormal temperatures, decreasing outward to about 20° to 30°C, still extend below the shot point to depths of 1.2 to 2.0  $R_c$  in granodiorite, and 2.7  $R_c$  in salt (Heckman, 1964). An approximation for the radial extent of significant residual temperature in reservoir rocks might be:

$$R_t = 2 R_c \quad (16)$$

An appreciable amount of residual thermal energy exists in a large volume of material exhibiting very low temperature increases, such as at the Rainier site, where some 50 percent of the energy release was deposited within material only 4°C above ambient temperatures. The persistence of such low temperature increases should vary directly with yield and inversely with any production rates, and in most cases without production, should remain for a number of years (Teller and others, 1968). However, Atkinson and Johansen (1964) emphasize that the long-term average temperature rise within the "radius of fracture" would be less than 1°C, and within the "crushed zone" would be only about 5°C. Figure 14, adapted from their data, indicates the estimated increase in ultimate recovery as a function of oil viscosity and the average temperature increase in both water-drive and solution-gas drive reservoirs. In both types, the general temperature increase of only a few degrees would not increase recovery significantly; the area of sustained higher increase is very local, and, although high viscosity oils would become more mobile within that area, any production would lead to an inevitable decrease in the temperature and a consequent return to higher viscosity and lower recovery.

---

NOTE, added May 1971.

As indicated above, theoretical considerations are generally supported by the limited empirical data from underground nuclear-explosion sites in forecasting only small and localized thermal effects. However, the following measurements at the Rulison site (Hamburger, April 1971, personal communication) do not fit into the predicted pattern: the pre-shot down-hole ambient temperature was 101°C, but the post-shot down-hole temperature recorded during gas-flaring production tests in the spring of 1971 averaged about 200°C and reached a maximum of

223°C. The reason for these anomalously high temperatures more than 18 months after detonation of the nuclear charge are not clear at this time, but the beneficial effect of heating on petroleum production may be greater than previously thought.

---

### Radioactivity

Any nuclear explosion produces a significant amount of radioactive debris, including fission fragments, fusion products, and radioactivity induced in other materials by neutron activation. A pure fission explosion produces about  $1.46 \times 10^{23}$  fissions or  $2.9 \times 10^{23}$  fission fragments per kiloton of energy (Miskel, 1964). These products are distributed in mass according to the yield curve shown in Figure 15; the general shape of the curve is the same for  $U^{235}$ ,  $U^{238}$ , and  $Pu^{239}$ . The fragments are neutron rich, and each successive beta decay process (with or without gamma radiation), averaging three in number, increases the nuclear charge one unit, thereby changing its chemical species, until, after a predictable time sequence, the fragment becomes stable. The excess neutrons in a fission explosion, about 1 or  $2 \times 10^{23}$  per kiloton, interact with other materials and induce radioactive species, mainly by neutron capture, which beta decay (with or without gamma radiation) directly to stable isotopes. A pure fusion explosion would produce no fission products, but each kiloton of energy produces about  $10^{23}$  atoms of tritium, beta-emitters creating approximately  $10^4$  curies radioactivity, and  $1.5 \times 10^{24}$  excess neutrons, or about 10 times as many as produced in the fission process.

Following a contained nuclear explosion, all radioactive nuclei which are not gaseous at the temperature of molten rock ( $1,500^\circ$  to  $2,000^\circ\text{C}$ ) are entrained in the melt and become a part of the almost completely insoluble glass puddle at the bottom of the cavity. "Prompt" venting of gases through ground fissures has occurred in only 3 of the more than 200 underground tests fired from 1961 to 1969 in stemmed vertical holes (U. S. Atomic Energy Commission, 1969a); in those cases, enough radioactivity was released to be detected outside of the controlled area. In the other tests, it is expected that most of the remaining gaseous nuclides plate out on the cool rubble as it falls through the gas during the process of chimney formation. A few nuclei, especially the noble gases, are gaseous at normal temperatures or develop by decay of normal gases. All volatile nuclides are diffused into the voids or fractures created by the explosions. The effects evaluation report for Rulison (U. S. Atomic Energy Commission, 1969c) suggests that the distribution of gamma-emitting radionuclides injected into the surrounding cracks above and below the shot point would average:

and 
$$H_g = 2.2 R_c \quad (17)$$

$$D_g = 1.5 R_c \quad (18)$$

A first approximation of volume affected might be reached by assuming:

$$R_g = 2 R_c \quad (19)$$

and then

$$V_g = 0.033 R_c \quad (20)$$

if volume is expressed in thousands of cubic meters. Delayed venting of a very small fraction of the radioactivity might occur by seepage to the surface after cavity collapse; this appears to have happened in some seven of the low-yield underground explosions from 1961 to 1969 (U. S. Atomic Energy Commission, 1969b), including one case in carbonate rock where unusually high pressure was built up by the creation of considerable  $CO_2$  in the chimney. No intermediate- or high-yield events have vented, and enough experience has been gained to correct earlier deficiencies.

The nature of the radionuclides produced by a nuclear explosion varies with the type of explosive device and the chemical nature of the specific surrounding rock. In a hypothetical Plowshare explosion with a yield of one megaton, assumed to be 1 percent fission and 99 percent fusion, in average crustal material with a saturated porosity of 20 percent, the products would vary in curie activity with time as shown in Figure 16 (after Stead, 1964). The fission products decrease rapidly -- by three orders of magnitude in the first week, and five orders of magnitude in the first year -- and, at the end of one year, only  $Sr^{90}$  and  $Cs^{137}$  are important. The fusion product, tritium or  $H^3$ , is the most abundant nuclide (by 2 orders of magnitude) after one year, and would remain important for more than one century. Induced radioactivity is relatively shortlived in the common metals (Al, Mn, Na, and Fe), and decreases rapidly -- by four orders of magnitude in the first week -- and, at the end of one year, only  $Co^{60}$  is significant. Although  $C^{14}$  is long-lived, the amount produced is insignificant, even in a hydrocarbon-rich reservoir, as  $C^{14}$  is created by activation of nitrogen and not carbon. In a contained nuclear explosion, only the long-lived radionuclides, particularly those with half-lives of considerably more than five years, are important in evaluating the post-explosion reentry and exploitation of petroleum reservoirs or the potential contamination of associated ground waters. Calculations of radioactivity for different examples are given in Table 5. Significant reduction in the amount of radioactivity (Lessler, 1970) can result by reducing the yield of the fission trigger in the nuclear device, by utilizing the least objectionable structural materials in the device, and by putting shielding or neutron-absorbing materials around the device.

For a gas-stimulation project, the gaseous phases of  $H^3$  and  $Kr^{85}$  appear to be the only important contaminants after a normal delay time. Higgins and Rodean (1965) anticipated that such contamination would decrease with production and be negligible after removal of 6 or 7 volumes of gas. Smith (1970) calculates that tritium and krypton isotopes made up the bulk of the contaminants in the Gasbuggy chimney ( $CH_3T = 80\%$ ,  $Kr^{85} = 15\%$ ,  $C^{14}$  and  $Ar^{39}$  in small amounts), and only 7 percent of the original concentration remained after removal of  $2\frac{1}{2}$  chimney volumes of gas. In the Rulison shot, a boron carbide shield around the fission device decreased the tritium by a factor of 3 or 4 (Frank and others, 1970). Decontamination of produced gas is being explored by special processing techniques (Wethington, 1970), such as washing the gas with water to remove  $H^3$  and with liquid nitrogen to remove  $Kr^{85}$ . However, economic utilization of the resource appears most practicable by a carefully controlled dilution and distribution system (Jacobs and others, 1970), or by the shipment of the gas to a remote power plant for conversion to a new energy form with controlled burning techniques.

For an oil-stimulation project, the radioactive gases may be of lower concentration, but the tritium developed from associated water may be significantly greater. The overall effect of exposure to gamma radiation of the oil samples at the Gnome Project was less than the overall effect of exposure to shock. Sample exposure to  $7 \times 10^5$  roentgens gamma radiation increased the polymerization in one oil and partially cracked another; the effect was less in the aromatic oils than in the paraffin oils. As expected, there was no residual radioactivity in the samples. The possible contamination of associated gas or water would also decrease with production, and decontamination by special processing techniques is also feasible.

For any petroleum-stimulation project, contamination of the ground water is a potential hazard, as the biologically significant radionuclides at explosion sites are at or a few orders of magnitude greater than the maximum permissible concentration in drinking water (see Table 5). Stead's (1964) summary of all empirical data indicates negligible transport of radionuclides from any past nuclear test site, but he emphasizes that the sites were carefully selected to minimize the possibility of widespread distribution of nuclides by ground-water transport. At such explosion sites, post-explosion ground-water movement appears to be towards the area of chimney collapse, and it may take considerable time to restore the pre-explosion water-table conditions -- one rubble chimney under observation did not fill with water until more than three years after the shot. The average velocity and direction of flow can be established from field observations, although locally maximum velocities several-fold larger than the average as well as anomalous dispersion phenomena do occur and may not be delineated. After restoration of the water table, radionuclides will be transported down the regional hydraulic gradient. Data accumulated

from current radioactive waste disposal experiences indicate that most fission products or neutron-activated nuclides participate in ion-exchange reactions with the rock matrix in such a way that the ions will move at significantly lower rates than the ground-water flow. In most cases, this is only a few percent or a fraction of a percent of the normal rate. These data also show that the concentrations will be diluted as the repetitive ionic adsorption cycle and diffusion distribute the radioactivity over a progressively larger area. Tritium, however, may not be so retarded; this, coupled with its dominance and long life, makes it the most important of all nuclides as a potential hazard in ground water. To avoid the tritium contamination in either the water or hydrocarbon deposits, Nordyke (1970) suggests the use of all-fission nuclear explosives in petroleum-stimulation projects.

Thus, because of slow water movement, radionuclide adsorption characteristics, and usually short decay rates, there has been no radiological contamination problems of ground-water wells within even a few kilometers of past test locations (Teller and others, 1968), but each future site will require full investigation and understanding of the geologic and hydrologic conditions so as to be able to predict where and when possibly hazardous concentrations of radionuclides can occur. As a case in point: one well drilled just outside of a rubble chimney to an aquifer less than 100 meters below the shot point exhibited no contamination five years after the event. It is further believed that, with careful planning, any radionuclides that are detected can be completely removed by currently envisioned decontamination processes (Wethington, 1970).

### Seismicity

Little of the great energy released by an underground nuclear explosion is converted to seismic energy. Mickey (1964) cites the latter as only 0.015 to 2.0 percent of the total for explosive yields ranging from 0.43 to 200 kilotons; Rodean (1970) cites a range from 0.01 to 1 percent depending upon the properties of the surrounding media. At teleseismic distance, Romney (1959) relates magnitude (M on the Wood-Anderson torsional seismograph) to yield (W) as follows:

$$M = 3.64 + \log_{10} W \quad (21)$$

Using this equation and calculating the energy received as a percentage of the total energy released, expectable values approximate 0.34% for 10 kt, 1.67% for 100 kt, and 6.67% for 1 megaton. However, the percentages calculated for actual events are anomalous as indicated by 0.14% for 11 kt and 0.08% for 100 kt, both in alluvium; 0.20% for 2.4 kt and 0.25% for 200 kt, both in tuff; and 0.24% for 0.43 kt in basalt. Generally, a larger fraction of seismic energy, particularly the higher frequencies, will be transmitted in the stronger, more competent, and less porous media, but most media behave quite similarly

under the water table. Even such very small percentages of the total explosive energies are sufficient to generate strong seismic pulses which create severe ground motion within an area near the explosion. The total amount of energy arriving at any one location is dependent mostly on the yield of the explosion, the geologic environment of the travel path, and the distance from the shot point. The high frequency energy generally is greatly reduced within several thousand meters of the shot point as the shock energy is transferred to the geologic environment, while low frequency energy attenuates very slowly and may be felt at much greater distances. The seismic energy received at any one point can be characterized by the frequency of ground motion ( $f$  in cycles per second) and three types of amplitude of ground motion: particle displacement ( $d$ ), particle velocity ( $v = 2 \pi f d$ ), and particle acceleration ( $a = 2 \pi f v$ ). These parameters can be predicted conservatively by equations developed from the extensive empirical data collected at the Nevada Test Site. Assuming that the shot point occurs in hard rock, as in a petroleum-stimulation project, the predicted peak surface motion will vary with yield ( $W$  in kt), slant distance ( $R$  in m), and station environment as follows (Kinnamon and others, 1967):

Station	Velocity or $v =$	Acceleration or $a =$
On hard rock	$8.64 \times 10^6 W^{0.73} R^{-1.87}$	$5.03 \times 10^5 W^{0.70} R^{-2.00}$ (22 & 23)
On alluvium	$2.94 \times 10^7 W^{0.73} R^{-1.87}$	$1.06 \times 10^6 W^{0.70} R^{-2.00}$ (24 & 25)

The predicted values for velocity and acceleration are plotted in Figure 17 for yields of 10, 50, and 100 kilotons. The damage criteria for such ground motions is based on much less empirical data which is often confused by failing to take into account very local conditions which can contribute to specific damage, such as pre-existing structural stresses resulting from settling, etc. For most industrial applications, a safety factor of 2 or more for the predicted distances is considered advisable. On the velocity plot, the traditional breaks for the empirically derived damage levels, particularly the U. S. Bureau of Mines findings, are indicated as derived from Mickey (1964) and others. On the acceleration plot, the classification by the "damage factor" is taken from Hughes (1968). Considerable effort is expended at U. S. Flowshare projects to avoid seismic damage, principally by choosing as remote and unpopulated sites as practicable. Careful monitoring of ground motion is conducted during each test. At Gasbuggy, it was predicted that there might be gas-well damage within about 400 meters of a 10-kt shot or about 1,200 meters of a 100-kt shot; residential plaster cracking might occur at distances up to 2.5 kilometers if 10 kt or 7.2 kilometers if 100 kt, and possibly there might be some settlement problems at greater distances. The actual shot yield was 29 kt which damaged one existing well 133 meters from the shot point but caused no damage to another well at a distance of 800 meters. Thus, ground

motions and the possibility of damage to structures can now be fairly accurately predicted (U. S. Atomic Energy Commission, 1969a).

Underground nuclear explosions expectably create subsequent seismic activity. Low-yield events are followed by tremors mostly associated with cavity collapse and chimney growth. High-yield events, such as the megaton Benham explosion of 19 December 1968, can cause some minor displacement along preexisting faults within 10 kilometers of the site and generate some aftershocks within 12 kilometers, all of which are of much smaller amplitude than those resulting from the nuclear event. Rodean (1970) states that seismic energies transmitted by chimney collapse and aftershocks are at least an order of magnitude weaker than those directly produced by an explosion. Current evidence indicates that proposed yields at Plowshare tests, similar to those anticipated at NTS, will not trigger damaging earthquakes or aftershocks (U. S. Atomic Energy Commission, 1969a).

### Economics

The economic factors surrounding the entire experimental program may have a decisive influence in ultimately limiting or controlling the application of explosions to petroleum-stimulation projects. Figure 18 indicates the relative planning costs which are based on thermonuclear explosives ranging from \$350,000 for a 10-kt device to \$600,000 for a 2-mt device -- these are charges which have been released by the AEC for the materials, fabrication, arming, and firing of a thermonuclear device for feasibility studies and evaluations. This is one of the largest items in any project budget, and must be reduced before any petroleum-stimulation test becomes economical. Not included but also of significance are the costs for feasibility analysis, exploratory work, site preparation, transportation and emplacement of device, and support functions. The emplacement hole is another major hurdle since costs increase exponentially with hole diameter and depth; Hill (1970) indicates that at depth of more than 2,300 meters, hole-related costs normally constitute more than 50 percent of the total cost.

Atkinson and Johansen (1964) suggested that a \$0.5 million stimulation-project investment would require the development of an extra 0.5 million barrels of oil to pay for it, which is such a significant increase in productivity as to be generally unlikely. Holzer (1970) estimates that the total gas in place in the 160 acres at the Gasbuggy site is only worth about 1 million dollars. Up to 1970, about \$50,000 worth of gas had been extracted. Table 6 shows an estimated total cost of 5.9 million dollars for the Rulison project but also indicates suggested realistic values for a future shot in the same field. Many significant reductions can be made as some operations do not require repetition and technological developments save expenses.

---

NOTE: added May 1971.

From the Rulison experience, Werth and others (1971) have estimated the total cost of 3 or 4 100-kt nuclear charges detonated in a single well in the Green River basin to be on the order of 2.5 million dollars, indicating that commercial gas-stimulation projects are becoming feasible with the current state-of-the-art.

---

### Public opinion

A major deterrent to the development of a more rapid timetable for conducting Flowshare experiments has been the adverse criticism generated nationally and locally. Watkins (1970) states that much of the opposition comes from those who are not fully aware of nuclear-explosion phenomenology - no legal case for opposition has been substantiated - and argues that improved public relations are required to better inform the general public about the real facts concerning nuclear detonations, particularly those associated with developing energy resources.

### U.S.S.R. PETROLEUM-INTENSIFICATION PROJECTS

Although the Soviets have an extensive nuclear testing program, their published technical conclusions are based almost wholly on published United States explosion experience, and, predictably, there is little disagreement about physical principles or effects. The Soviets do theorize (U.S.S.R. Academy of Sciences, 1969) that the size of the nuclear explosion cavity is more closely related to the crushing strength of the surrounding rock than to the lithostatic pressure, and that the maximum cavity volume reached during the explosion sequence exceeds the final volume (they calculate by 1.5 and 2 times respectively for the Gnome and Salmon explosions). Such theoretical differences have little significance in regard to the physical effects that need to be considered in petroleum-stimulation projects.

The Soviet philosophic position and technical criteria applicable to the "intensification" of petroleum production were rather fully stated by Kedrovskiy and Mangushev in 1967 and amplified by Mangushev and Zolotovitskaya in 1969. The Soviets stress that since only 35 to 45 percent of existing petroleum resources are recovered from reservoirs, and because current extraction techniques are time-consuming and costly, nuclear explosions can substantially increase and sustain the yield, decrease the exploitation time, and ultimately leave less petroleum in the rock. The Soviets claim considerable theoretical and some experimental investigation and modeling, including both chemical and nuclear explosions at both proving grounds and industrial sites; test

environments have evidently included granite, shale, limestone, clay, salt, and sandstone, and shot points have been buried as deep as 1,500 meters. Kedrovskiy (1970) clearly emphasizes that the positive results at one major multiple nuclear-explosion site in an experimental oilfield have encouraged them to propose at least two other large-scale applied projects, Scheme I and Scheme II, all of which are impressive in their magnitude. In currently commercial, moderately permeable carbonate reservoirs containing natural gas or water-driven oil, the Soviets produce a fracture pattern by nuclear explosions within the deposit or below the petroleum-water interface, and thereby create greater permeability and water pressure. The stated objective is faster, and thus more economic, exploitation of a commercial field. The environmental data for these U.S.S.R. projects are summarized in Table 7 and are presented graphically in Figures 19 to 24. The available literature suggests the following discussion of the specific effects of underground nuclear explosions as related to petroleum intensification projects.

### Fracturing

The Soviets recognize fracturing as the primary phenomena in production intensification. They differ little from the Americans in their general description of the fracture zone, and commonly cite the U. S. parametric values for  $R_c$ ,  $H_f$ , and  $L_f$ . However, Kedrovskiy and Mangushev (1967) suggest that the asymmetry of fracturing around a shallow shot point would be less marked at greater depths and that individual fractures may extend beyond predicted distances. Mangushev and Zolotovitskaya (1969) and Kedrovskiy (1970) talk of radial fracture zones at depths of about 1,500 meters with parameters as indicated in Table 8. The one completed test at the experimental oilfield with two 2.3 kt explosions at a depth of 1,340 meters produced a fracture pattern as also indicated in Table 8. The U.S.S.R. Academy of Sciences (1969) similarly implies a theoretical spherical distribution of fractures extending to distances on the order of one magnitude larger than the cavity ( $R_p = 10 R_c$ ). All of these figures represent a more optimistic view, both as to configuration and magnitude, than that supported by previous American experience.

The Soviets evidently have been greatly impressed by the difference in the fracture pattern between rock types, stressing that maximum fracturing is expectable in the most brittle rocks. Mangushev and Zolotoviskaya (1969) conclude that the reservoir rocks most amenable to fracturing are carbonates, a conclusion which they support by citing the physical changes reported in the exposed samples of Project Gnome. They further emphasize that carbonate reservoirs are widespread, containing about 77 percent of the Soviet oil deposits and 18.5 percent of the gas reserves (other gas reserves include 10 percent

in clastic rocks with carbonate cement, and 48.5 percent in clastic rocks with clay-carbonate cement).

#### Effect on reservoir permeability

The Soviets readily recognize that the fractures created by nuclear explosions will create a drainage zone in a productive reservoir that is larger by several orders of magnitude than that of a standard borehole, and thereby appreciably increase yield. Mangushev and Zolotvitskaya (1969) emphasize that this effect would be greatest in carbonate reservoirs, almost all of which can benefit from artificial improvement of their permeability; 65 percent of such Soviet oil reservoirs have natural permeabilities of less than 100 millidarcies, and most Soviet gas deposits are in less permeable reservoirs (specifically citing the Stavropol' gas-condensate reservoir as ranging from 5 to 20 md. and that of Yefromovskiy as less than 5 md.). The low permeability of the carbonate oil reservoirs is responsible for the low ultimate recovery percentages of the oil deposits, averaging less than 40 percent recovery for all and barely reaching 20 percent recovery in 40 percent of the deposits. A contributing cause also is the high viscosity of some of the oil; 18 percent of such deposits contain oil with a viscosity greater than 50 centipoises.

In the completed test at the experimental oilfield (Kedrovskiy, 1970), the carbonate reservoir, a massive reef, had a permeability of 3 to 100 millidarcies, averaging 25 to 30 md., but during the 7 years of production by solution-gas drive, the formation pressure dropped from 137 to 30 kg/cm<sup>2</sup>. The flow of oil to the wells spaced on a 200-meter grid was mostly by solution-gas drive and gravity, and thus production was decreasing; maximum normal recovery capability was estimated at about 30 percent of the total resource with some 7 or 8 million tons of oil being left in the reservoir. Kedrovskiy (1970) states that after nuclear-explosion fracturing in special drill holes (first by two 2.3-kt devices fired with a 100 millisecond delay and later by one 8-kt device), immediate increases in yield were evident and production generally stabilized throughout the field some 30 percent to 60 percent above previously projected rates, and the ultimate recovery percentage is expectably greater.

Other petroleum-intensification projects anticipate similar results. Scheme I involves three 40-kt explosions within a gas deposit in a carbonate reef reservoir, and Kedrovskiy (1970) predicts that fracturing will increase production by ten-fold, shorten exploitation time by eleven-fold, and save 5 to 6 million rubles in total operating costs. Scheme II involves three 20- to 30-kt explosions centered below the oil-water interface of an oil deposit in a domed carbonate sequence with dense interbeds; Kedrovskiy (1970) predicts that the fracturing

will destroy the oil-water interface and some of the interbeds, thereby promoting increased water pressure on the oil and stabilized production at a high level for almost another decade (fig. 24).

All of the Soviet projects appear to be within conventionally commercial fields with moderate permeability values ranging 2 or 3 orders of magnitude higher than those of the U. S. sites considered for stimulation projects (see fig. 8) -- again pointing up their emphasis on intensification of production; that is, more at a faster rate with concomitant operational savings.

#### Effects on reservoir geometry

The Soviets appear equally cognizant of the need to match the reservoir dimensions to the magnitude of the nuclear explosion phenomena. To confine the effective power of the blast to the reservoir rock, Mangushev and Zolotovitskaya (1969) suggest first priority reservoirs should have thicknesses of no less than 50 to 60 meters, and 30 meters might be considered a minimum thickness. Ninety-eight percent of Soviet oil reserves in carbonate rocks occur in reservoirs exceeding 30 meters in thickness, and 50 percent in reservoirs exceeding 50 meters; 50 percent of Soviet gas reserves occur in reservoirs more than 30 meters thick. Two of the project sites have reef structures 450 to 500 meters thick, and the third has a domed carbonate reservoir with a maximum thickness exceeding 100 meters.

The minimal permissible containment depth (in meters) is a function of the cube root of yield (in kilotons) times a lithologic constant which is cited by Kedrovskiy and Mangushev (1967) to vary between 100 and 150 (see equation 15). Mangushev and Zolotovitskaya (1969) indicate 500 meters as an arbitrary safe depth of burial -- a dimension that occurs in 99.5 percent of all Soviet oil deposits in carbonate reservoirs, and essentially all Soviet gas deposits. All petroleum-intensification projects are conducted at very safe depths.

To protect a petroleum resource, the caprock must also be of sufficient thickness and the device placed properly so that the explosion does not breach the cap. Mangushev and Zolotovitskaya (1969) suggest a minimum thickness ranging between 50 and 100 meters and note that 90.9 percent of the larger Soviet oil deposits have a caprock exceeding 100 meters, and most Soviet gas deposits have a caprock between 50 and 100 meters thick. Conversely, suitable reservoirs should not be so deep that technical or economical difficulties are encountered during the drilling of the requisite large-diameter holes. Mangushev and Zolotovitskaya (1969) recommend in the light of current technology that explosions should be at depths preferably no greater than 2,000 meters. Eighty-eight percent of the Soviet oil deposits in carbonate reservoirs occur between the depths of 500 and 2,000 meters, and 71 percent of the Soviet gas deposits are at depths of less than 2,000

meters. The Soviet petroleum-intensification projects all have emplacement depths of about 1,500 meters.

### Heating

The Soviets acknowledge the great amount of energy deposited as heat, but, because rocks are such poor conductors, they stress the local nature of its effect and its inability to heat large masses of oil-bearing rocks. The radial extent of significant temperature rise is cited by Kedrovskiy and Mangushev (1967) as:

$$R_t = 24.7 W^{1/3} \quad (26)$$

Even such local thermal effects may warrant special additional study, particularly since 18 percent of Soviet oil reserves in carbonate reservoirs have viscosities of more than 50 centipoises, and might be amenable to thermal stimulation. However, the experimental oilfield test was conducted in a solution-gas-drive oil with a viscosity of 6 centipoises; as indicated in Figure 14, the temperature would have to have an average rise of 10°C over a sizable volume of rock to increase the ultimate recovery from the reservoir by as much as 10 percent -- the likelihood of any appreciable stimulation by heating at this site can be considered negligible, and none was observed (Kedrovskiy, 1970).

### Radioactivity

The Soviets exhibit complete awareness of the theoretical and empirical data on radiochemical phenomena. However, Kedrovskiy and Mangushev (1967) bluntly state that with proper design of device, borehole, and sealer that "one can avoid completely the radiation contamination of the atmosphere, of the work region, and of the petroleum being extracted." Mangushev and Zolotovitskaya (1969) properly emphasize that most radioactivity (85 to 90 percent) is entrapped in the insoluble residual melt, and postulate that the remainder is scattered underground in the form of short-lived isotopes of inert gases which can be easily contained. Any contamination of the petroleum products can be controlled by delaying exploitation or diluting them with uncontaminated products. Thus, the Soviets see no real threat of any radiation danger in underground nuclear explosions for petroleum intensification. One beneficial product of explosions in the carbonate rocks at Soviet sites is the potentially large amount of CO<sub>2</sub> that would be released (Taylor and others, 1970). This release might lead to a significant increase in formation pressure and add to productivity.

The Soviets stress that at the completed test in the experimental oilfield, oil was produced throughout the operation from the

adjacent wells and subsequently from reentry wells into the chimney with no radiological complications.

### Seismicity

The Soviets undoubtedly have complete documentation of the seismic energy release from their nuclear explosions and its potential hazards. Kedrovskiy and Mangushev (1967) suggest that with the proper choice of size of device and proper emplacement procedures, it is quite possible to have explosions within operating fields without damaging other boreholes or engineering structures. Mangushev and Zolotovitskaya (1969) emphasize the stability of the boreholes and surface installations at the U. S. Gnome, Salmon, and Gasbuggy sites, and suggest 10- to 20-kt explosions can be safely carried out at distances of 20 to 30 kilometers from large industrial and inhabited centers. The determination of the minimum safe distance ultimately becomes an economic question -- balancing gain against potential loss.

The experimental oilfield test already conducted, the largest blast of which was 8 kt, created no seismic damage (Kedrovskiy, 1970) to adjacent operating wells, the closest of which were within 100 to 120 meters, but some chimneys fell and plaster was cracked in structures 1,500 to 2,000 meters from the site. Larger yields could have been used in such circumstances.

### Economics

From available data, it is impossible to itemize cost factors for nuclear devices or site development within the U.S.S.R. If device preparation costs are absorbed under one agency and not paid by the petroleum-intensification operation, then the proposed projects would soon pay for themselves. The anticipated savings of 5 to 6 million rubles in the Scheme I project could even cover the cost of the device. All operations apparently are aimed at the specific economic goals of greater, faster, and cheaper production -- not development of marginal deposits with questionable futures, but stepped-up exploitation of known quantities. Such a framework may permit more accurate economic predictions and develop a viable pay-as-you-go system of projects. The Soviets have declared that petroleum-intensification projects are no longer experimental, and that they are prepared to offer this service to other countries.

## SUMMARY

Underground nuclear explosions have obvious application as possible energy sources for the stimulation of noncommercial or depleted petroleum deposits to increase both production rates and ultimate recovery percentages. The principal beneficial physical effect of such an explosion is the creation of an extensive pattern of fractures permitting both more rapid flow of petroleum to wells and increasing possible hydrodynamic pressures on the deposit. The beneficial effect of heating by such an explosion generally has been considered small and localized, but this conclusion may have to be revised after all the data from the Rulison project have been evaluated. The radiological and seismic hazards of such an explosion must be fully understood and taken into account, but both apparently are predictable and controllable. Economic barriers, particularly the cost of the nuclear device, remain the principal deterrent to wider utilization of this application of nuclear energy.

Both the U. S. and the U.S.S.R. have active experimental programs concerned with petroleum-stimulation projects. It is hoped that this presentation of available data on the environment at the Flowshare sites in the U.S. and corresponding sites in the U.S.S.R. provides a basis for comparison of the stated American and Soviet philosophy and technical criteria. Extensive detailed data have been published on the environment at U.S. sites, particularly for the projects in progress, Gasbuggy and Rulison, but also including the proposed Dragon Trail, Wagon Wheel, and WASP. Fairly specific data recently have been released by the Soviets on the one admitted experimental oilfield site, and more limited data have been published on the environment of the proposed sites for Schemes I and II. The available data clearly indicate significant differences in both approach and objectives; the comparison tabulated below and shown in Figure 25 emphasizes such differences.

Feature	U. S. Statement	U.S.S.R. Statement
Stated Purpose	Raise submarginal deposits to commercial level.	Raise production rates and decrease exploitation costs in commercial deposits.
Nature of Reservoir	Moderately deep (300 to 2,500 meters below surface), thick (> 60 meters), low permeability (0.1 to 1.0 millidarcies), clastic sequence (with more permeable sands) of Upper Cretaceous age; stratigraphic trap.	Moderately deep (500 to 2,000 meters below surface), thick (> 60 meters preferable, 30 to 60 meters minimal), moderate permeability (1 to 100 millidarcies), carbonate sequence (with higher porosity zones) of Permo-Carboniferous age; structural trap.
Nature of Petroleum	Natural gas (or low viscosity oil?) with depletion drive.	Natural gas or oil with either depletion drive or water drive.
Nature of Cap	Thick, impermeable clastic sequence.	Thick, impermeable saline sequence.
Explosion	Within reservoir to increase permeability.	Within reservoir or below water interface to increase permeability and water drive.

## References

- Atkinson, C. H., and Johanson, R. T., 1964, A study of the feasibility of using nuclear explosions to increase petroleum recovery: U. S. Bur. Mines Rept. Inv. 6494, 18 p.
- Atkinson, C. H., Ward, D. C., and Lemon, R. F., 1970, Gasbuggy reservoir evaluation - 1969 report, in Symposium on engineering with nuclear explosives, Proc., v. 1: Am. Nuclear Soc. and U. S. Atomic Energy Comm. CONF 700101, p. 722-731.
- Boardman, C. R., 1970, Engineering effects of underground nuclear explosions, in Symposium on engineering with nuclear explosives, Proc., v. 1: Am. Nuclear Soc. and U. S. Atomic Energy Comm., CONF 700101, p. 43-67.
- Boardman, C. R., Rabb, D. D., and McArthur, R. D., 1964, Contained nuclear explosions in four media -- geological factors in cavity and chimney formation, in Engineering with nuclear explosives, Plowshare Symposium, 3rd, Proc.: U. S. Atomic Energy Comm., TID-7695, p. 109-126.
- Boardman, C. R., and Skrove, J., 1966, Distribution in fracture permeability of a granitic rock mass following a contained nuclear explosion: Jour. Petroleum Technology, v. 18, p. 619-623.
- Cauthen, L. J., Jr., 1964, Survey of shock damage to surface facilities and drilled holes resulting from underground nuclear detonations: Univ. Calif. Lawrence Radiation Lab., UCRL-7964, 33 p.
- CER Geonuclear Corp., 1968, Technical Plan, Project Rulison, 31 p.
- Coffer, H. F., Bray, B. D., and Knutson, C. F., 1964, Applications of nuclear explosives to increase effective well diameters, in Engineering with nuclear explosives, Plowshare Symposium, 3rd, Proc.: U. S. Atomic Energy Comm., TID-7695, p. 269-287.
- Coffer, H. F., and others, 1964, Effects of nuclear explosions on oil reservoir stimulation: Jour. Petroleum Technology, v. 16, p. 473-480.
- Continental Oil Co., 1968, The stimulation of a natural gas reservoir by a contained nuclear explosion, in U. S. Congress, Joint Committee on Atomic Energy, Subcommittee on Legislation: U. S. 90th Cong., 2nd sess., Hearings on Commercial Plowshare Services and related background material, app. 15, p. 361-372.

- Delort, F., and Supiot, F., 1970, Nuclear stimulation of oil-reservoirs, in Symposium on engineering with nuclear explosives, Proc., v. 1: Am. Nuclear Soc. and U. S. Atomic Comm., CONF 700101, p. 649-661.
- Delrich, S., 1970, Underground nuclear explosions effects in granite rock fracturing in Symposium on engineering with nuclear explosives, Proc., v. 1: Am. Nuclear Soc. and U. S. Atomic Energy Comm., CONF 700101, p. 505-518.
- El Paso Natural Gas Company, 1965, Project Gasbuggy: prepared with U. S. Atomic Energy Comm., U. S. Bur. Mines and Univ. Calif. Lawrence Radiation Lab., PNE-1000, 57 p.
- Frank, G. W., Coffey, H. F., and Luetkehaus, G. R., 1970, Economics of nuclear gas stimulation, in Symposium on engineering with nuclear explosives, Proc., v. 1: Am. Nuclear Soc. and U. S. Atomic Energy Comm., CONF 700101, p. 577-596.
- Frank, W. J., 1964, Characteristics of nuclear explosives, in Engineering with nuclear explosives, Plowshare Symposium, 3rd, Proc.: U. S. Atomic Energy Comm., TID-7695, p. 7-10.
- Hansen, S. M., and Lombard, D. B., 1964, Completely contained nuclear explosives for mining by caving, in Engineering with nuclear explosives, Plowshare Symposium, 3rd, Proc.: U. S. Atomic Energy Comm., TID-7695, p. 371-383.
- Heckman, R. A., 1964, Deposition of thermal energy by nuclear explosives, in Engineering with nuclear explosives, Plowshare Symposium, 3rd, Proc.: U. S. Atomic Energy Comm., TID-7695, p. 289-303.
- Higgins, G. H., 1970, Summary of nuclear explosion data for underground engineering applications: Univ. Calif. Lawrence Radiation Lab., UCRL-50853, 6 p.
- Higgins, G. H., and Rodean, H. C., 1965, Some calculations for effecting stimulation by nuclear means: Soc. Petroleum Engineers, 40th annual meeting, SPE-1301, p.
- Higgins, G. H., and Butkovich, T. R., 1967, Effect of water content, yield, medium and depth of burst on cavity radii: Univ. Calif. Lawrence Radiation Lab., UCRL-50203, 24 p.
- Holzer, Alfred, 1970, Gasbuggy in perspective, in Symposium on Engineering with nuclear explosives, Proc., v. 1: Am. Nuclear Soc. and U. S. Atomic Energy Comm., CONF 700101, p. 662-697.
- Holzer, Fred, ed., 1967, Gasbuggy preshot summary report: Univ. Calif. Lawrence Radiation Lab., UCRL-50345, 20 p.

- \_\_\_\_\_. ed., 1968, Gasbuggy preliminary postshot summary report: Univ. Calif. Lawrence Radiation Lab., PNE-1003, 16 p.
- Hughes, B. C., 1968, Nuclear construction engineering technology: U. S. Army Engineer Nuclear Cratering Group, NCG Tech. Rept. no. 2, 182 p.
- International Nuclear Corp., 1969, Feasibility study: Wyoming Atomic stimulation Project (WASP), 160 p.
- Jacobs, D. G., and others, 1970, A preliminary assessment of the radiological implications of commercial utilization of natural gas from a nuclearly stimulated well, in Symposium on Engineering with nuclear explosives, Proc., v. 1: Am. Nuclear Soc. and U. S. Atomic Energy Comm., CONF 700101, p. 831-849.
- Kedrovskiy, O. L., 1970, Perspektivy primeneniya podzemnykh yadernykh vzryvov v narodnom khozyaystve Sovetskogo soyuza (Prospects for using underground nuclear explosions in the Soviet national economy): U.S.S.R., State Comm. on Atomic Energy, 21 p. (English translation UCRL-Trans-10477).
- Kedrovskiy, O. L., and Mangushev, K. I., 1967, (On the possibility of using nuclear explosives for increasing productivity of oil and gas deposits and the intensification of their exploitation): Geologiya Nefti i Gaza, no. 12, p. 12-16 (English translation appears as JPRS 44,486--Use of underground nuclear explosions in oil-gas mining).
- Kinnamon, R. L., and others, 1967, Preliminary safety evaluation for Project Bronco in The Bronco Oil Shale Study, U. S. Atomic Energy Comm., U. S. Dept. Interior, CER Geonuclear Corp., and Univ. Calif. Lawrence Radiation Lab., app. D, p. 58-62.
- Lessler, R. M., 1970, Reduction of radioactivity produced by nuclear explosives, in Symposium on engineering with nuclear explosives, Proc., v. 2: Am. Nuclear Soc. and U. S. Atomic Energy Comm., CONF 700101, p. 1563-1568.
- Lewis, A. E., 1970, Chemical mining of primary copper ores by use of nuclear technology, in Symposium on engineering with nuclear explosives, Proc., v. 2: Am. Nuclear Soc. and U. S. Atomic Energy Comm., CONF 700101, p. 909-917.
- Loux, P. C., 1970, Seismic motions from Project Rulison, in Symposium on Engineering with nuclear explosives, Proc., v. 2: Am. Nuclear Soc. and U. S. Atomic Energy Comm., CONF 700101, p. 1069-1082.

- Mangushev, K. I., and Zolotovitskaya, E. A., 1969, (Prospects of using nuclear explosions in developing oil and gas deposits): *Geologiya Nefti i Gaza*, no. 4, p. 20-24 (English translation JPRS 48,338).
- McArthur, R. D., 1963, Geologic and engineering effects: The Hardhat Event, GNI-63, 24 p.
- Mickey, W. V., 1964, Seismic wave propagation, in Engineering with nuclear explosives, Plowshare Symposium, 3rd, Proc.: U. S. Atomic Energy Comm., TID-7695, p. 181-194.
- Miskel, J. A., 1964, Characteristics of radioactivity produced by nuclear explosives, in Engineering with nuclear explosives, Plowshare Symposium, 3rd, Proc.: U. S. Atomic Energy Comm., TID-7695, p. 153-159.
- Mueller, R. A., 1970, Prediction of seismic motion from contained and excavation nuclear detonations, in Symposium on engineering with nuclear explosives, Proc., v. 2: Am. Nuclear Soc. and U. S. Atomic Energy Comm., CONF 700101, p. 1051-1068.
- Nordyke, M. D., 1970, Technical status summary of peaceful uses for nuclear explosives: Univ. Calif. Lawrence Radiation Lab., UCRL-72332, 46 p.
- Rabb, D. D., 1970, Particle-size distribution study: Piledriver Event, in Symposium on engineering with nuclear explosives, Proc., v. 2: Am. Nuclear Soc. and U. S. Atomic Energy Comm., CONF 700101, p. 888-908.
- Rawson, D. E., and others, 1968, Postshot geologic investigation -- Project Gasbuggy: Univ. Calif. Lawrence Radiation Lab., UCRL-71354, 26. p.
- Reynolds, Miles, Jr., and others, 1970, Project Rulison: a preliminary report, in Symposium on engineering with nuclear explosives, Proc., v. 1: Am. Nuclear Soc. and U. S. Atomic Energy Comm., CONF 700101, p. 597-628.
- Richter, C. F., 1958, Elementary seismology: San Francisco, W. H. Freeman and Co., 768 p.
- Rodean, H. C., 1970, Explosion-produced ground motion: technical summary with respect to seismic hazards, in Symposium on engineering with nuclear explosives, Proc., v. 2: Am. Nuclear Soc. and U. S. Atomic Energy Comm., CONF 701001, p. 1024-1050.

- Rogers, L. A., 1970, Determining the explosion effects on the Gasbuggy reservoir from computer simulation of the post shot gas production history, in Symposium on engineering with nuclear explosives, Proc., v. 1: Am. Nuclear Soc. and U. S. Atomic Energy Comm., CONF 700101, p. 698-721.
- Romney, C., 1959, Seismic measurements, Plowshare Symposium, 2nd, Proc.: Univ. Calif. Lawrence Radiation Lab., UCRL-5675, pt. 1.
- Short, N. M., 1964, Effects of shock pressures from a nuclear explosion on mechanical and optical properties of granodiorite: Univ. Calif. Lawrence Radiation Lab., UCRL 7949, 25 p.
- Smith, C. F., 1970, Gas quality analysis and evaluation program for Project Gasbuggy, in Symposium on engineering with nuclear explosives, Proc., v. 1: Am. Nuclear Soc. and U. S. Atomic Energy Comm., CONF 700101, p. 775-793.
- Stead, F. W., 1964, Distribution in ground water of radionuclides from underground nuclear explosions, in Engineering with nuclear explosives, Plowshare Symposium, 3rd, Proc.: U. S. Atomic Energy Comm., TID-7695, p. 127-138.
- Sterrett, T. S., 1969, Detailed geology of the proposed Dragon Tail experimental site, Rio Blanco, Colorado: Univ. Calif. Lawrence Radiation Lab., UCRL-50566, 31 p.
- Taylor, R. W., and others, 1970, Interpreting the chemical results of the Gasbuggy experiment, in Symposium on engineering with nuclear explosives, Proc., v. 1: Am. Nuclear Soc. and U. S. Atomic Energy Comm., CONF 700101, p. 794-814.
- Teller, Edward, and others, 1968, The constructive uses of nuclear explosives: New York, McGraw-Hill Book Co., 320 p.
- U. S. Atomic Energy Commission, Nevada Operations Office, 1969a, Safety of underground nuclear testing: TID-24996, 20 p.
- \_\_\_\_\_ 1969b, Technical discussions of off-site safety programs for underground nuclear detonations: NVO-40(Rev. 2), 27 p.
- \_\_\_\_\_ 1969c, Effects evaluation for Project Rulison: NVO-43(Final), 33 p.
- U.S.S.R., Academy of Sciences, Institute of Terrestrial Physics, 1969, Mechanical effect of underground nuclear explosions: Atomic Energy Comm., Translation 7120, 10 p.

- U.S.S.R., State Committee on Atomic Energy, 1969, Review of possible peaceful applications of nuclear explosions in the national economy of the Soviet Union: Internat. Atomic Energy Agency Translation 69-8047, 15 p. (Also AEC-Tr-7121, 23 p.)
- Vasil'ev, V. G., ed., 1968a, Neftyanyye mestorozhdeniya SSSR (Oil deposits of U.S.S.R.): Geologiya nefiti; Spravochnik, v. 2, no. 1, Moscow, Izd-vo Nedra, 763 p.
- \_\_\_\_\_ ed., 1968b, Gasovye mestorozhdeniya SSSR (Gas deposits of U.S.S.R.): Spravochnik, 2nd ed., Moscow, Izd-vo Nedra, 686 p.
- Watkins, J. W., 1970, Hydrocarbon production with nuclear explosives, in Symposium on engineering with nuclear explosives, Proc., v 1: Am. Nuclear Soc. and U. S. Atomic Energy Comm., CONF 700101, p. 567-576.
- Werth, G. C., and others, 1971, An analysis of nuclear explosive gas stimulation and the program required for its development: Univ. Calif. Lawrence Radiation Lab., UCRL-50966.
- Wethington, J. A., Jr., 1970, Possible techniques for decontamination of natural gas from gas wells stimulated by a nuclear explosion, in Symposium on engineering with nuclear explosives, Proc., v. 2: Am. Nuclear Soc. and U. S. Atomic Energy Comm., CONF 700101, p. 1589-1596.

Figure 1. Underground nuclear explosion phenomenology  
Schematic diagrams suggested by Gasbuggy data (see Table 2)

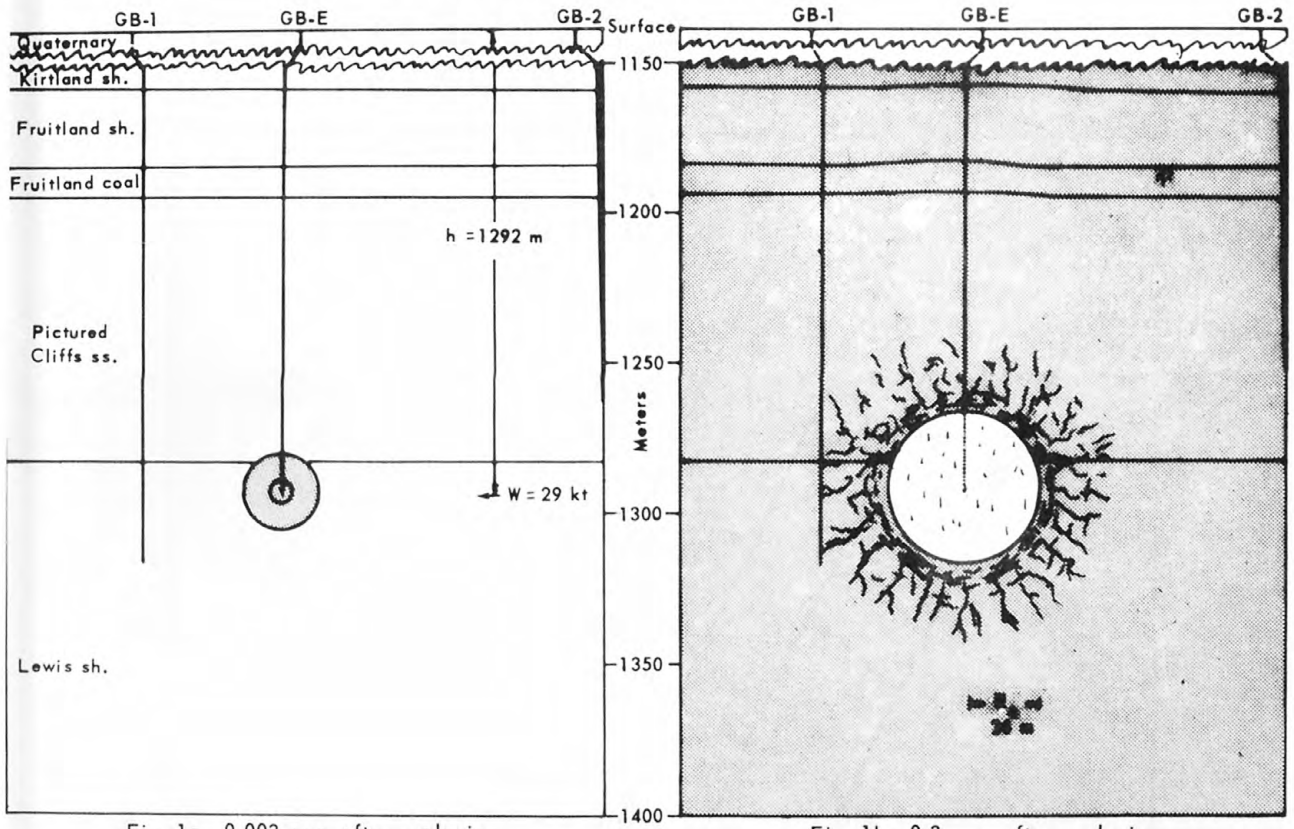

Fig. 1a. 0.003 sec. after explosion

Fig. 1b. 0.3 sec. after explosion

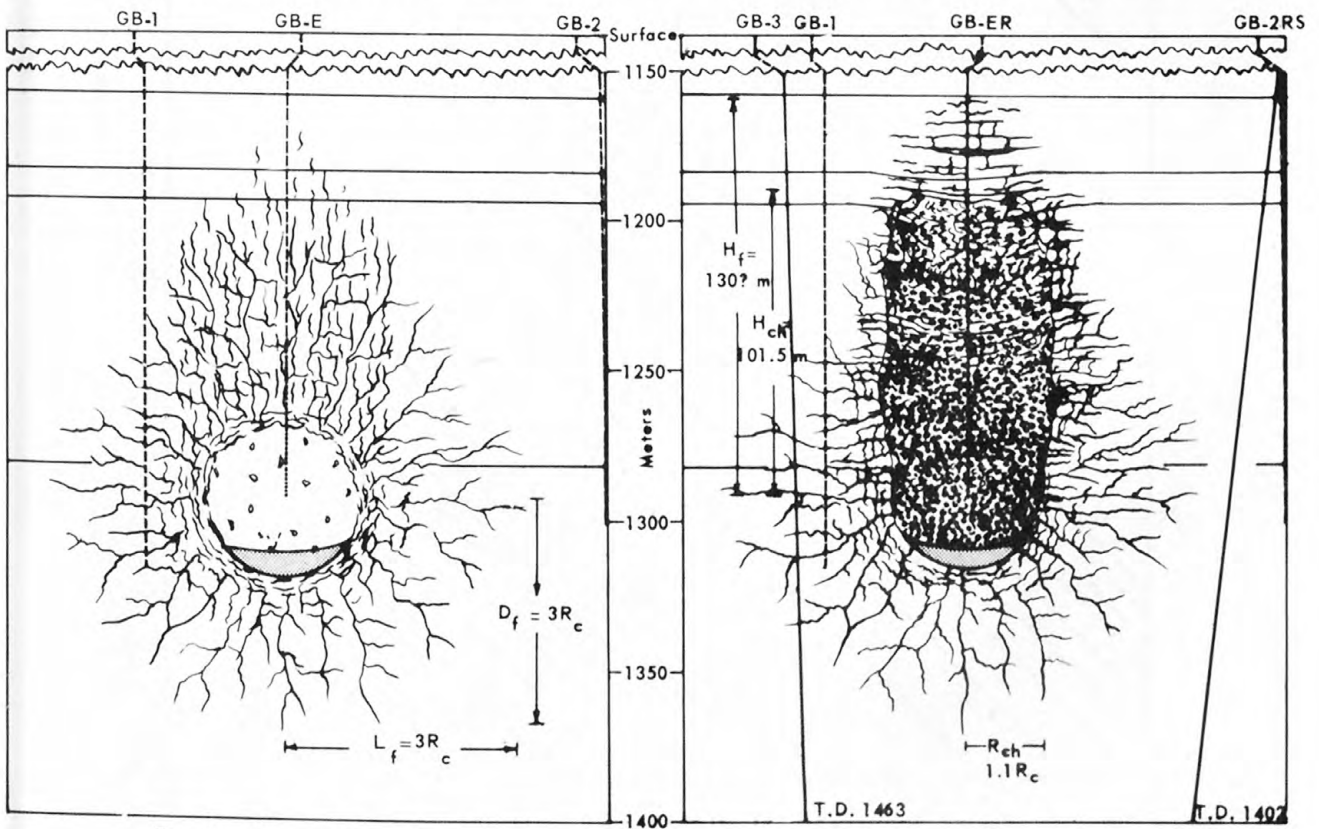
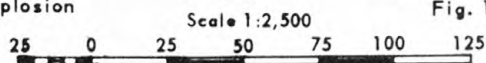

Fig. 1c. 3 sec. after explosion

Fig. 1d. Final configuration



Meters  
No vertical exaggaration

Figure 2. Relationships of yield, depth, and cavity radius and volume in granite  
 (After Lewis, 1970)

Granite has  $C_c=100$ ,  $\rho=2.6$  g/cc,  $\alpha=0.32$  for 2.5% H<sub>2</sub>O

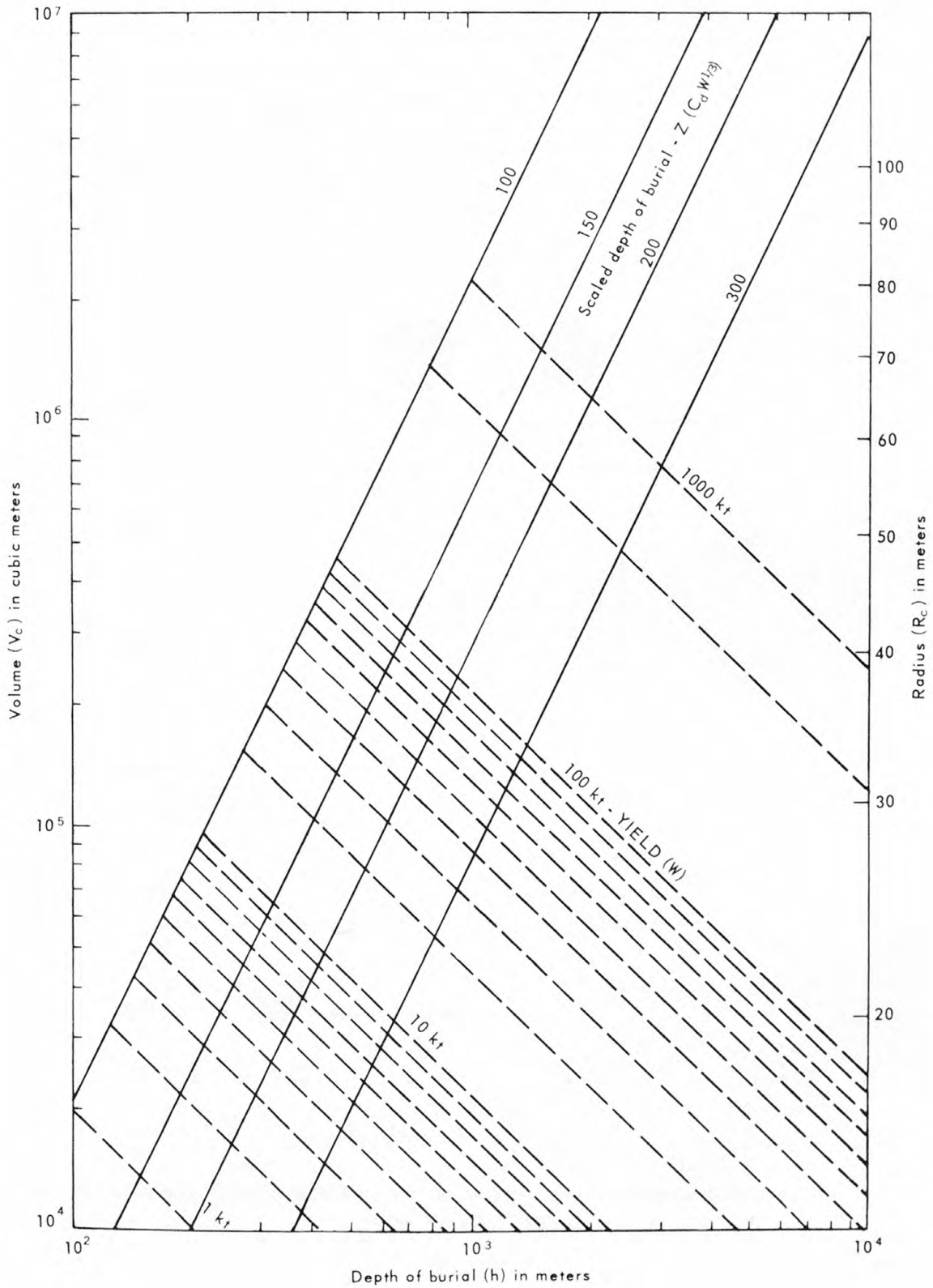

SOC model studies of 30 kt explosions at various depths  
and in various lithologies

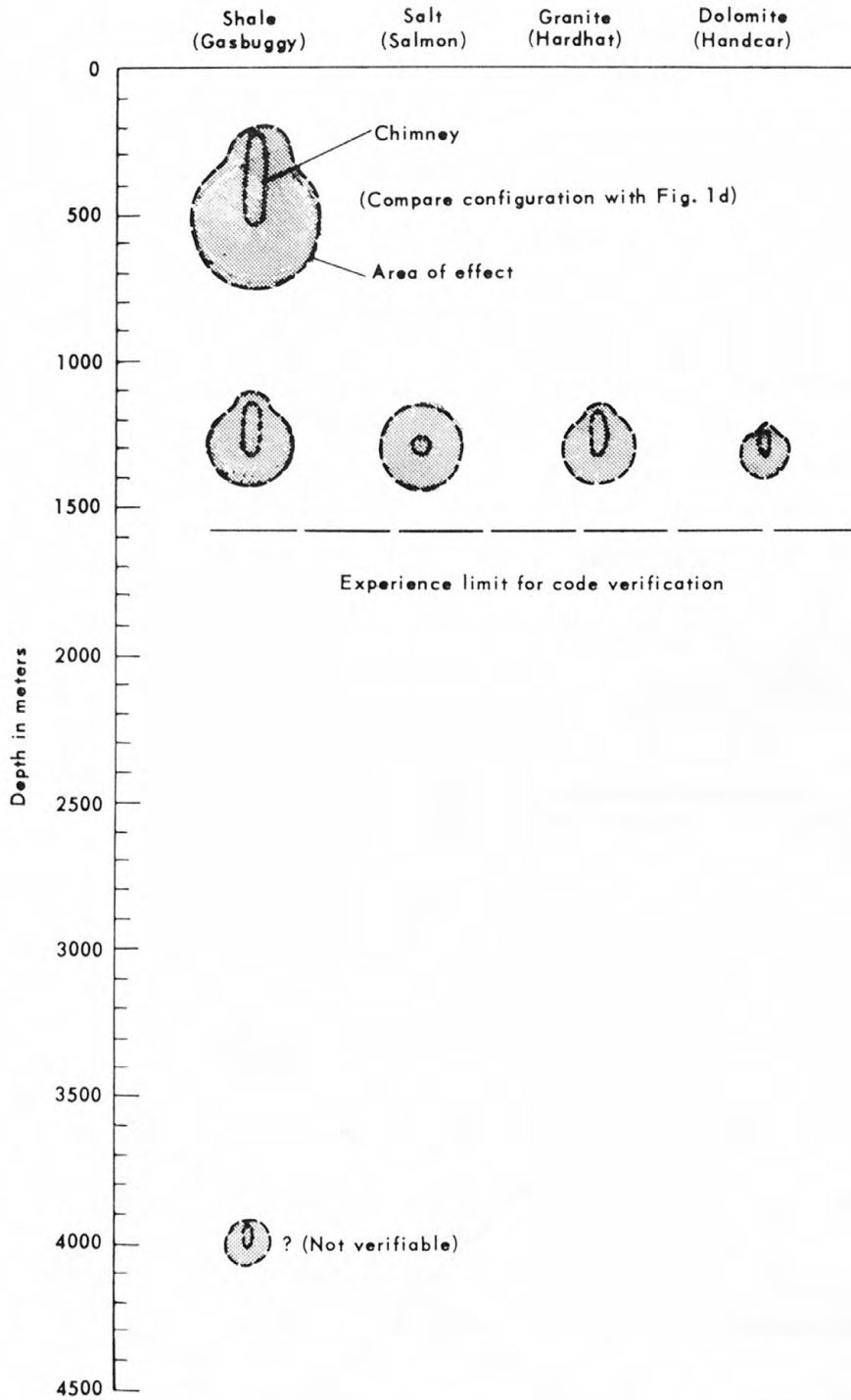

Figure 3. Effects of rock mechanics on underground nuclear explosions  
(After Nordyke, 1970)

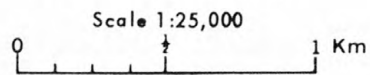

Table 3. Suggested parametric values for explosion phenomena in selected petroleum reservoir rocks (see text for equation derivation)

Radius of cavity .....	$R_c = 9^*$	$W^{1/3}$ (2a)
Radius of chimney .....	$R_{ch} = 1.1$	$R_c$ (3)
Height of chimney .....	$H_{ch} = 4$	$R_c$ (4a)
Void volume in chimney .....	$V_{ch} = 3$	$W$ (5a)
Lateral extent of fractures .....	$L_f = 3$	$R_c$ (10a)
Height of fractures .....	$H_f = 7$	$R_c$ (8a)
Radius of fracturing .....	$R_f = 3.9$	$R_c$ (12)
(if considered spherical)	$= 35$	$W^{1/3}$ (13)
Volume of fractured rock .....	$V_f = 0.25$	$R_c^3$ (11a)
(if considered spherical)	$= 175$	$W$ (14)

(Note: all values are metric)

\* Figure will vary with density of material, depth of burial, and water contact (see equation 7).

Figure 4. Plots of parametric values for explosion phenomena in petroleum reservoir rocks (see Tables 2 and 3)

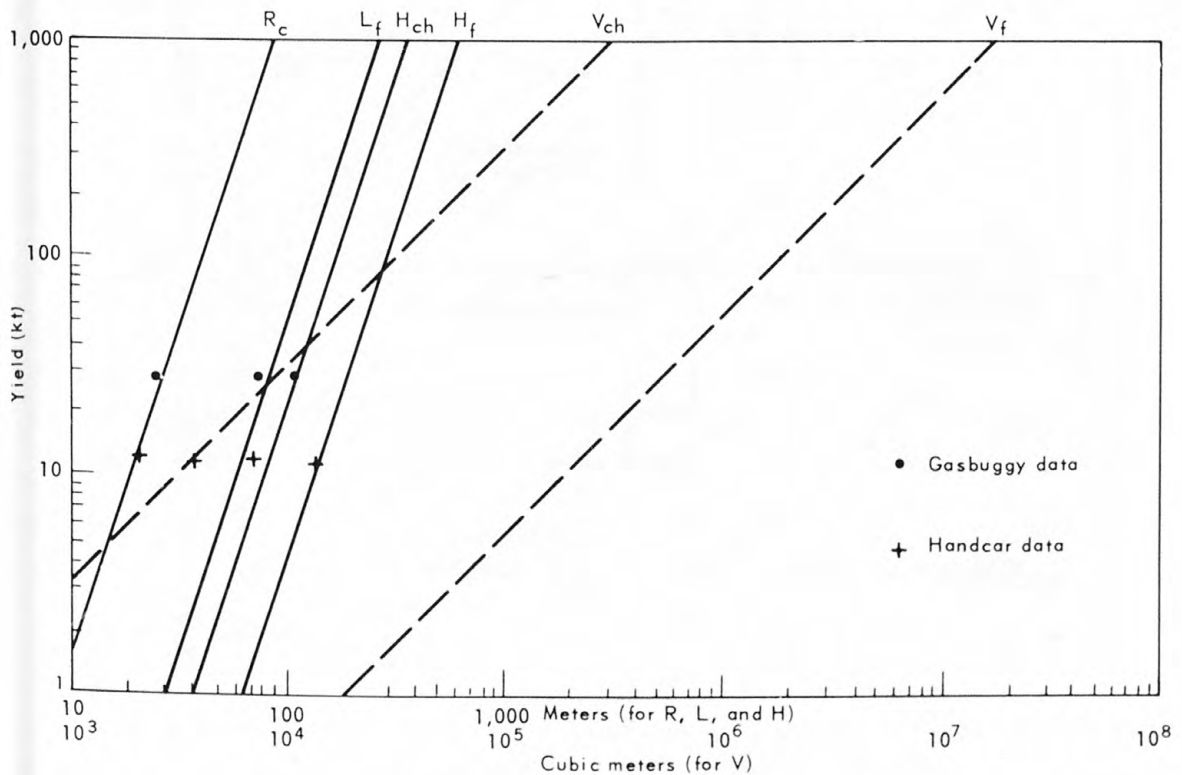

Table 4. Behavior of reservoir rock samples subjected to nuclear explosion  
(Data from Coffey et al, 1964)

Lithology Formation	Max. Press. (kbar)	Permeability (md)			Porosity (%)			Comp. Strength (kg/cm <sup>2</sup> )		
		Un-shocked	Shocked	% Change	Un-shocked	Shocked	% Change	Un-shocked	Shocked	% Change
Limestone										
Amsden	3.8	3.6	4.4	+ 22	< 0.1	0.1	---	813	850	+ 5
Madison	4.8	0.1	0.9	+900	< 0.1	0.2	+100	550	504	- 8
Madison	6.6	1.5	2.6	+ 73	< 0.1	< 0.1	---			
Madison	8.4	1.3	2.1	+ 62	< 0.1	< 0.1	---			
Dolomite										
Embar	3.7	16.8	18.5	+ 10	10	27	+ 170			
Embar	4.7	12.6	10.0	- 21	26	0.2	- 99			
Embar	6.5	5.0	9.5	+ 90	0.2	1.0	+ 400	740	94	- 87
Embar	8.4	6.5	16.8	+158	0.6	15	+ 2400			
Sandstone										
Tensleep	3.8	15.4	13.8	- 10	83	36	- 57	714	527	- 26
Tensleep	4.7	18.3	18.4	+ 1	188	169	- 10	452	275	- 39
Tensleep	6.5	19.4	18.7	- 4	440	205	- 53	339	166	- 51
Tensleep	8.4	14.1	15.0	+ 6	203	25	- 88	670	100	- 85
Sandstone										
Puente	3.7	19.6	22.7	+ 16	26	13	- 50			
Repetto	4.7	20.2	28.6	+ 42	160	61	- 62			
Repetto	6.5	24.4	21.0	- 14	150	16	- 89	73	44	- 40
Repetto	8.4	24.2	22.8	- 6	93	38	- 59	21	19	- 10

Figure 5

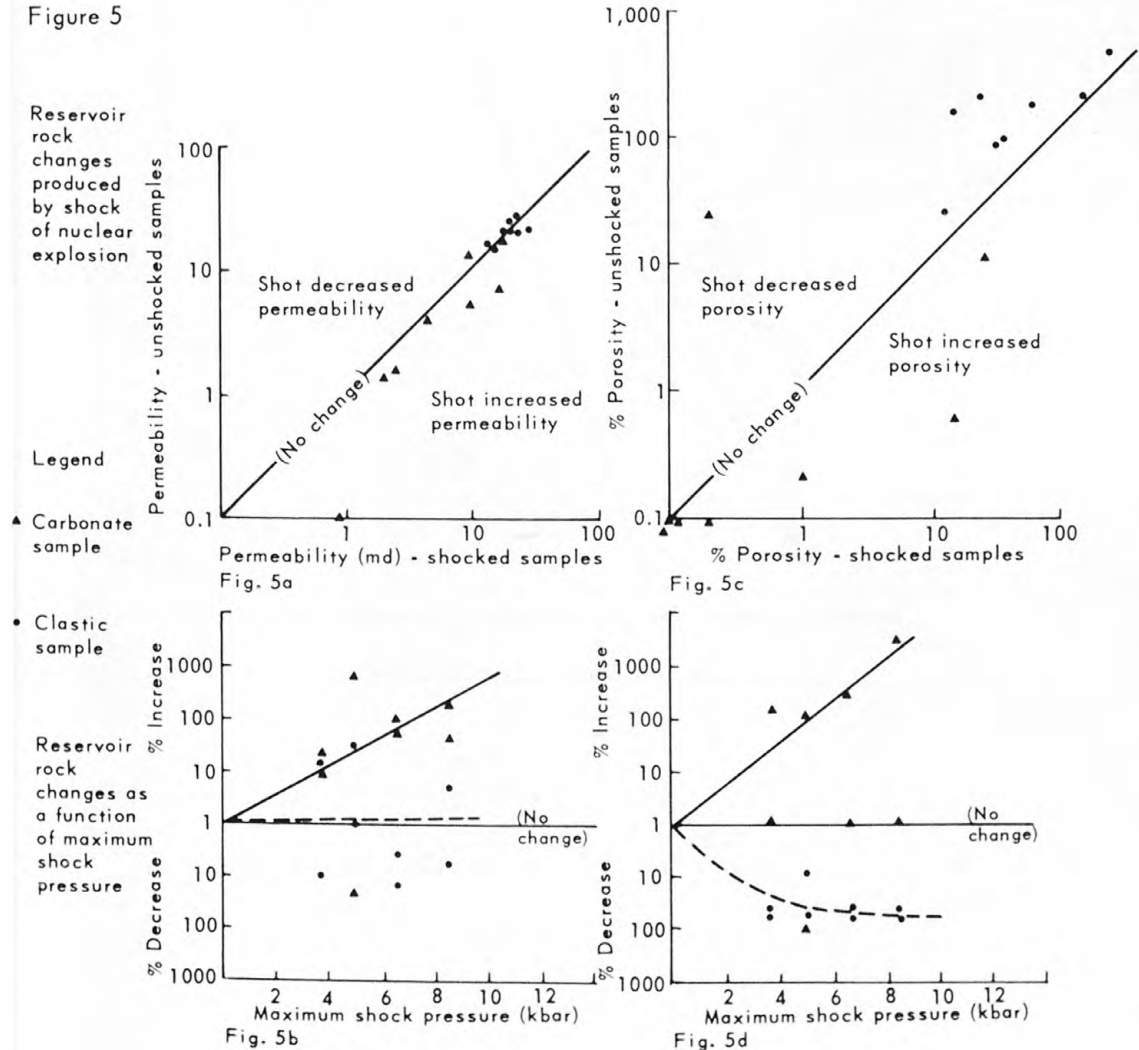
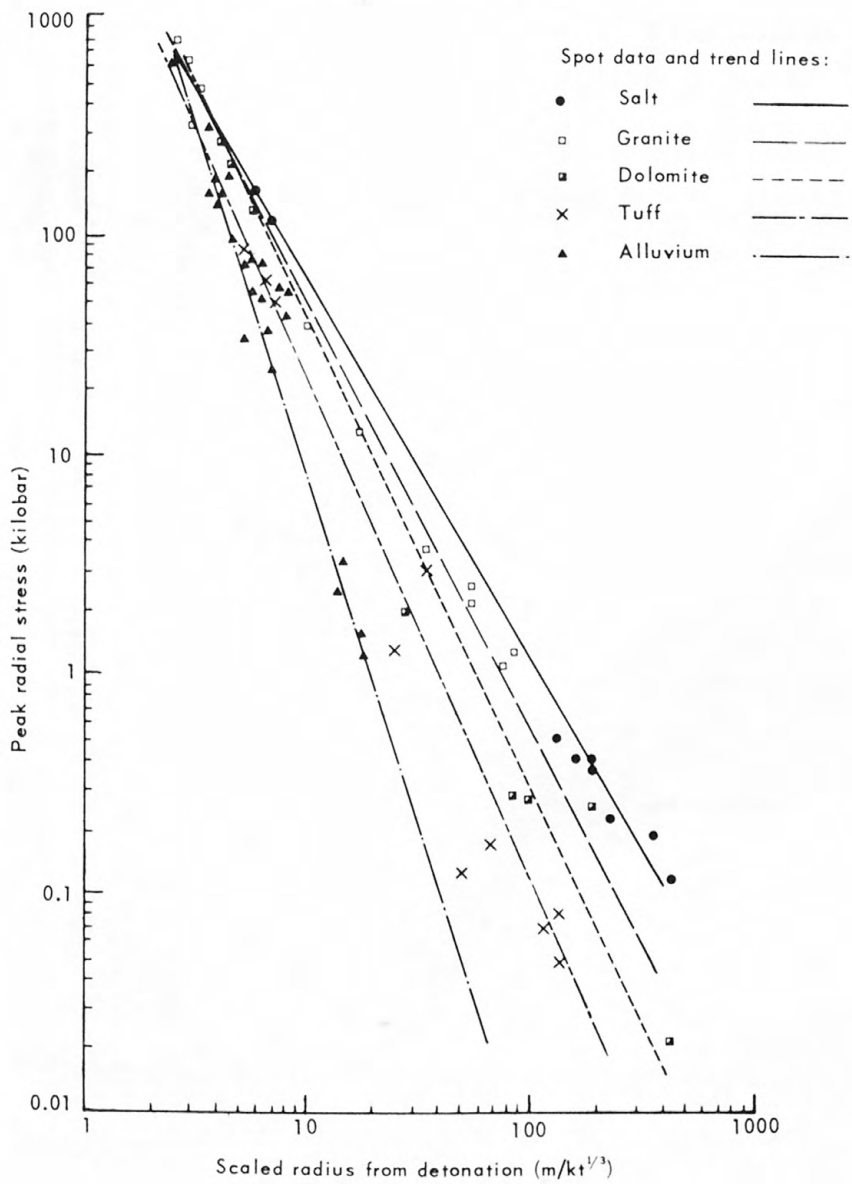

Figure 6. Peak stress for underground nuclear explosions  
(After Rodean, 1970)



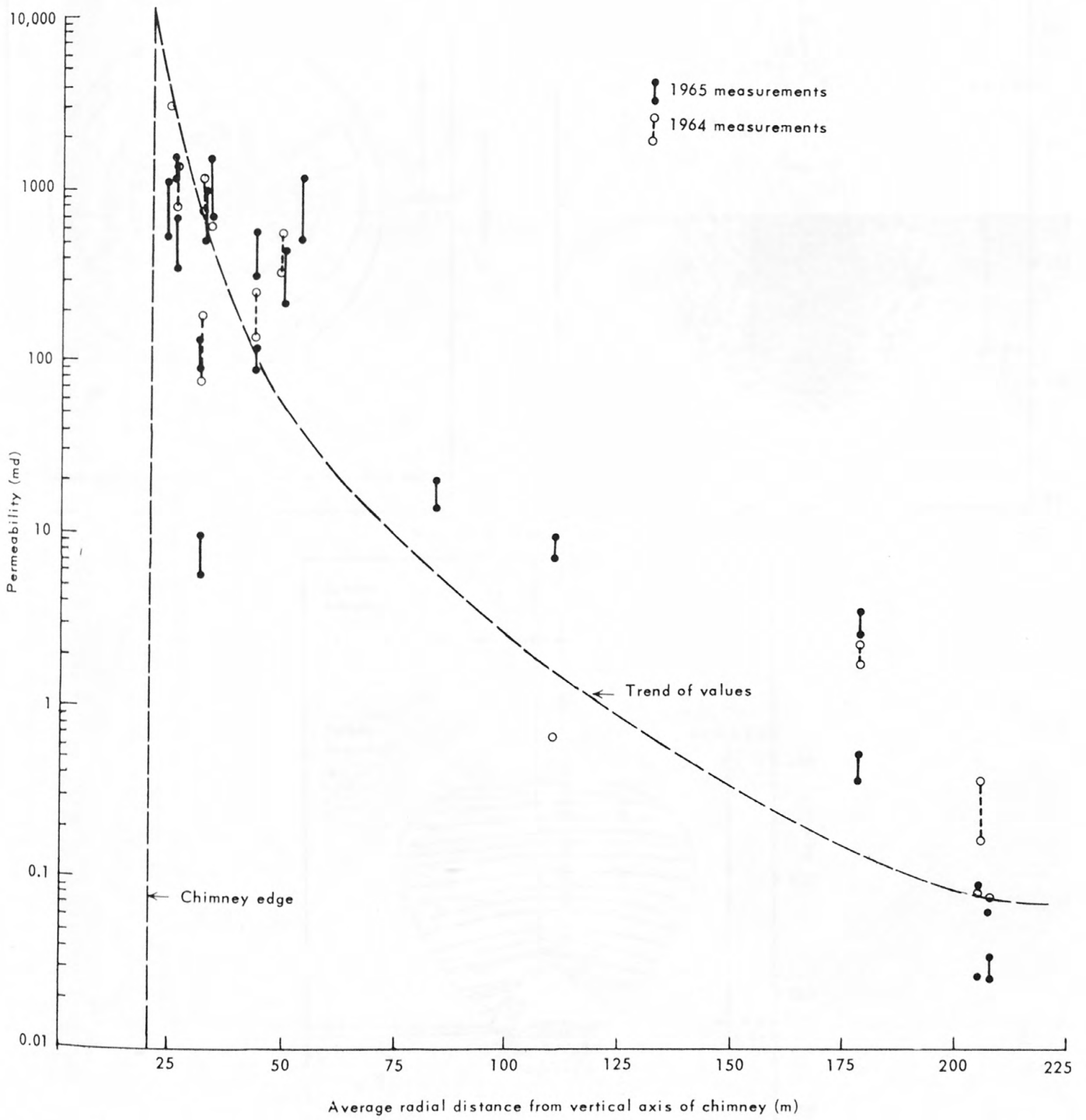
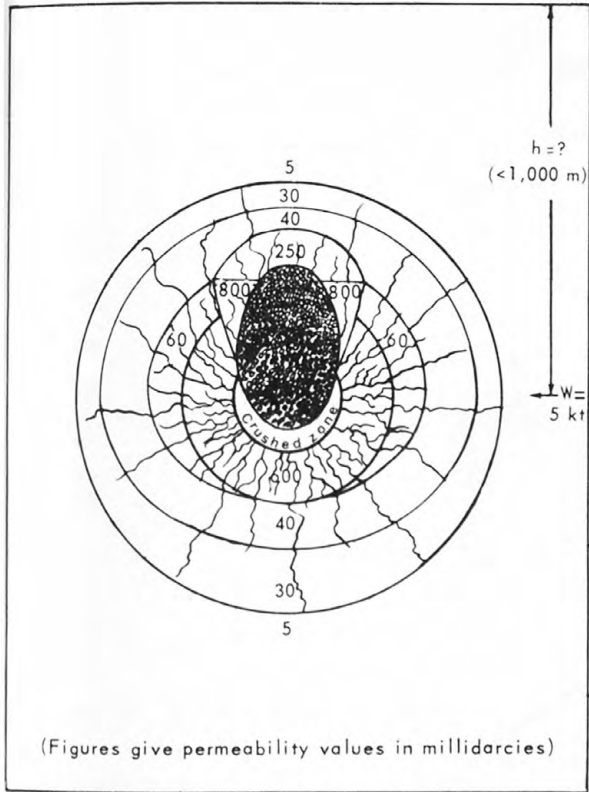

Figure 7. In situ permeability of Hardhat chimney wall rock  
(Data from Boardman and Skrove, 1966)

Figure 8. Permeability distribution at explosion sites

Hoggar site (After Delort and Supiot, 1970)



Hardhat site (McArthur, 1963)

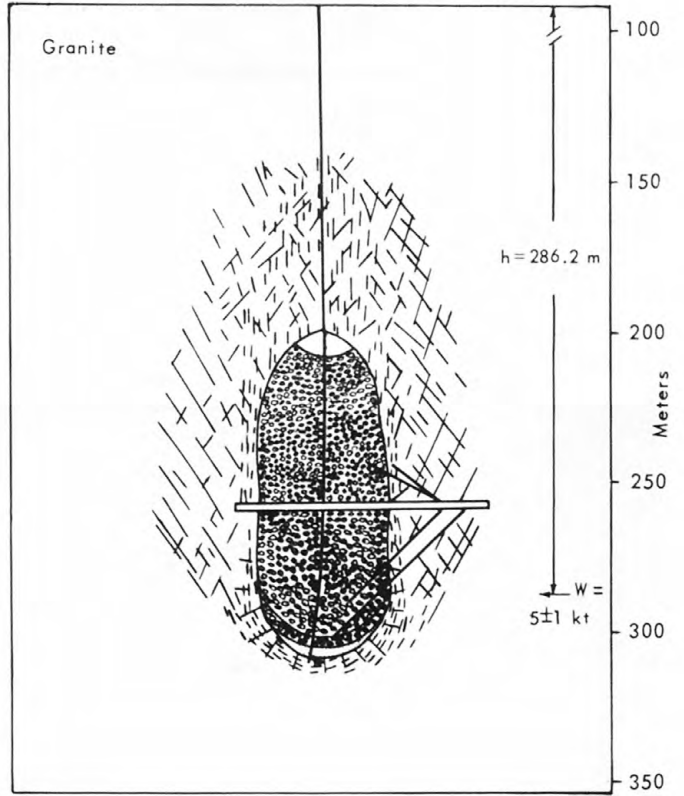

Gnome site (Coffer et al, 1964)

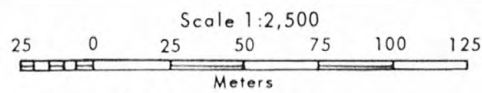
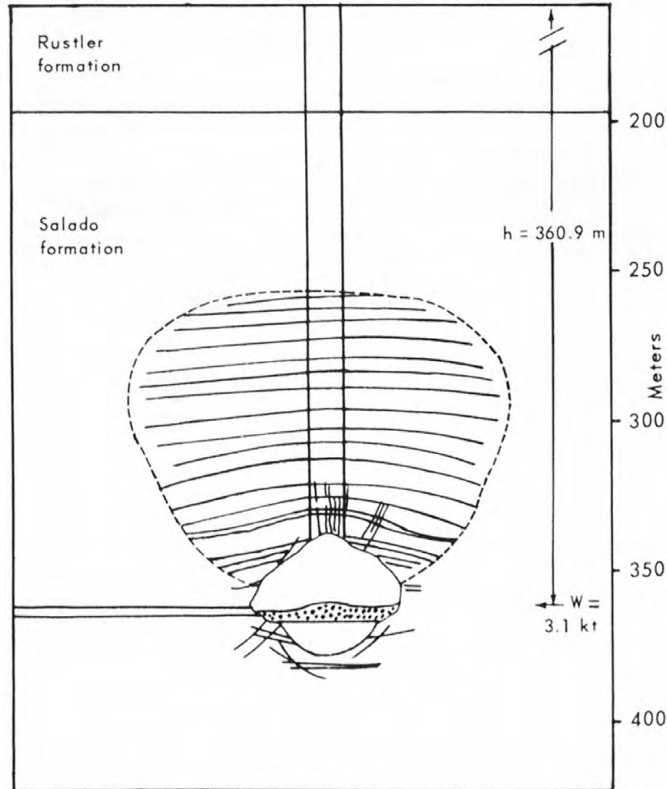

No vertical exaggeration

Figure 9. Effects of reservoir permeability and device yield on ultimate recovery

(After Frank et al, 1970)

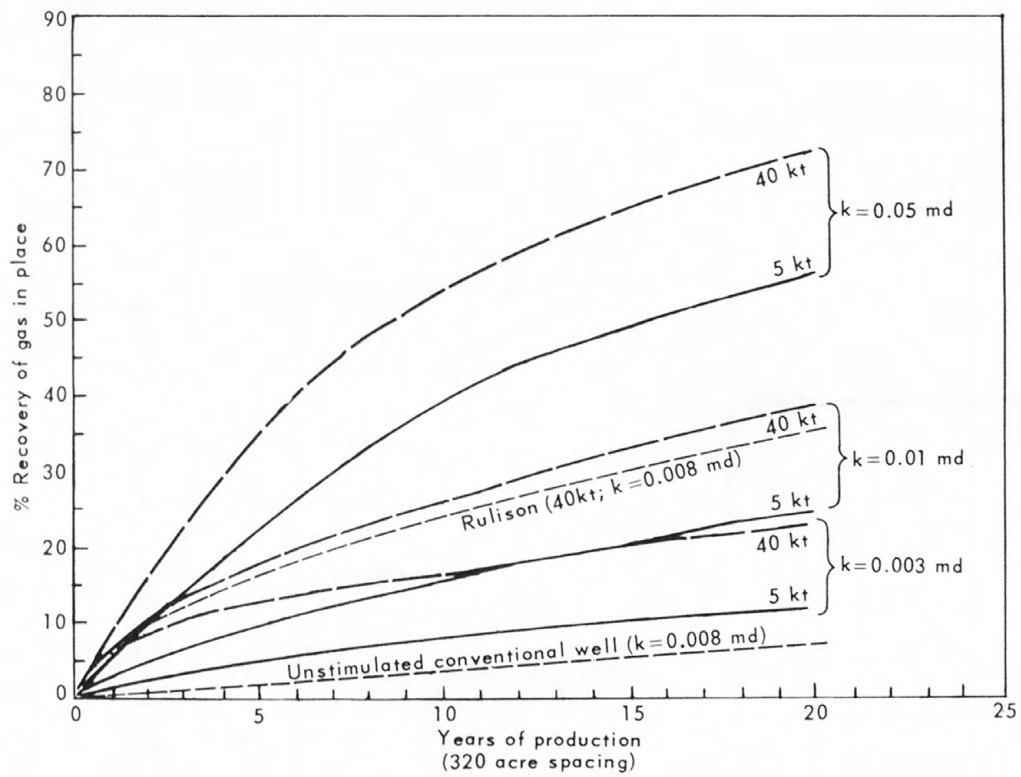

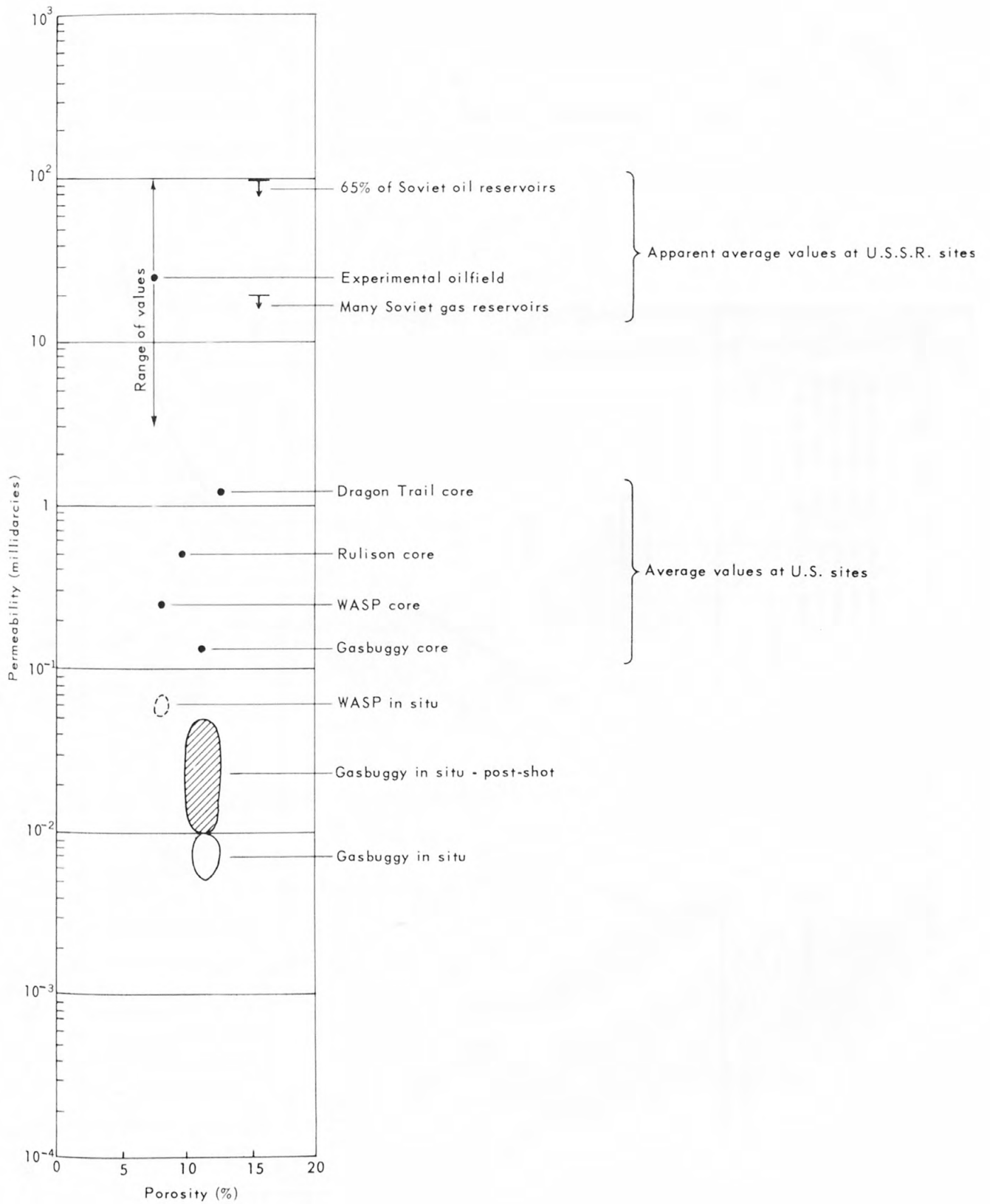

Figure 10. Core permeability and petroleum-stimulation project sites

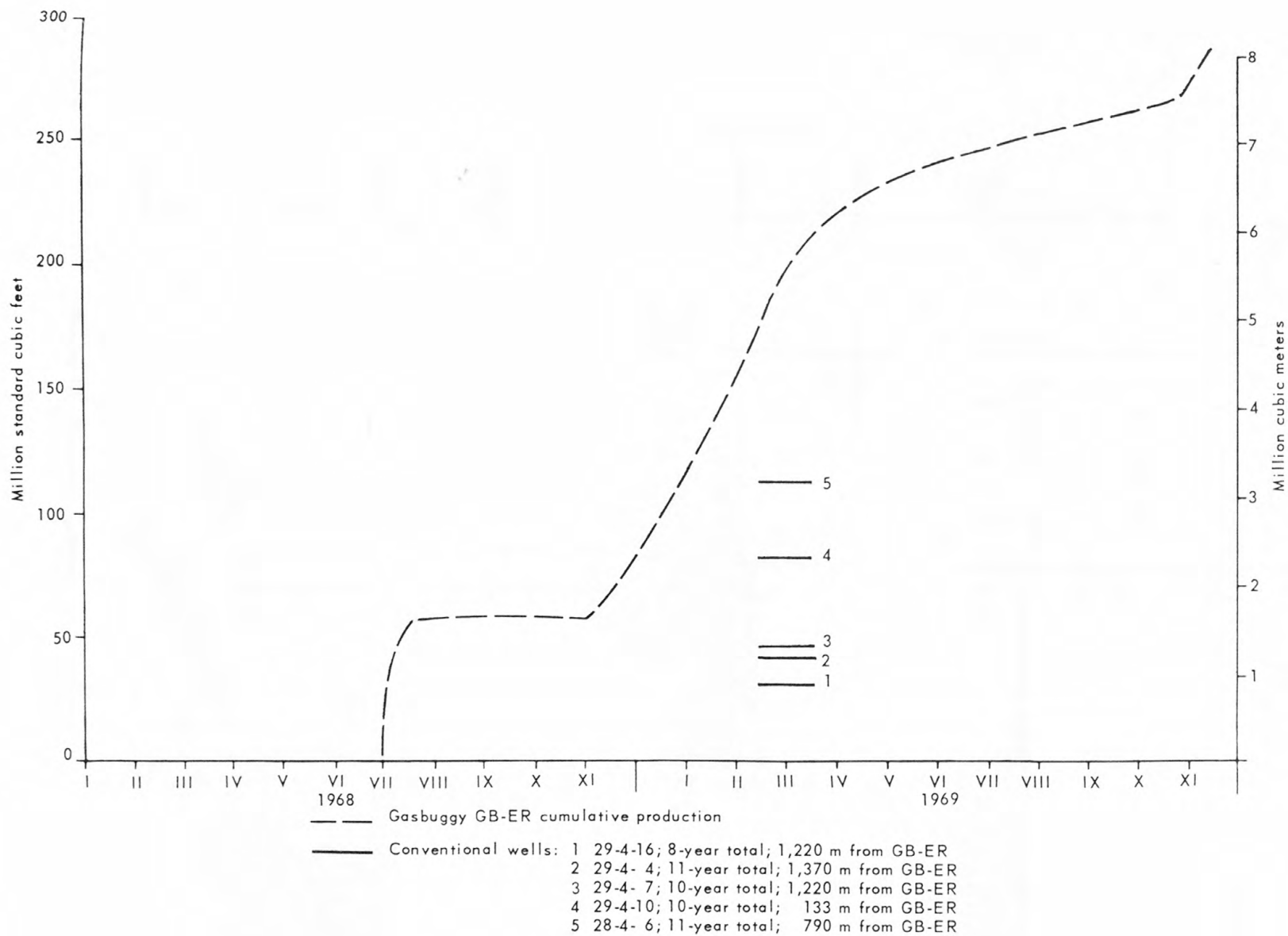

Figure 11. Production history of the Gasbuggy site (After Holzer, 1970)

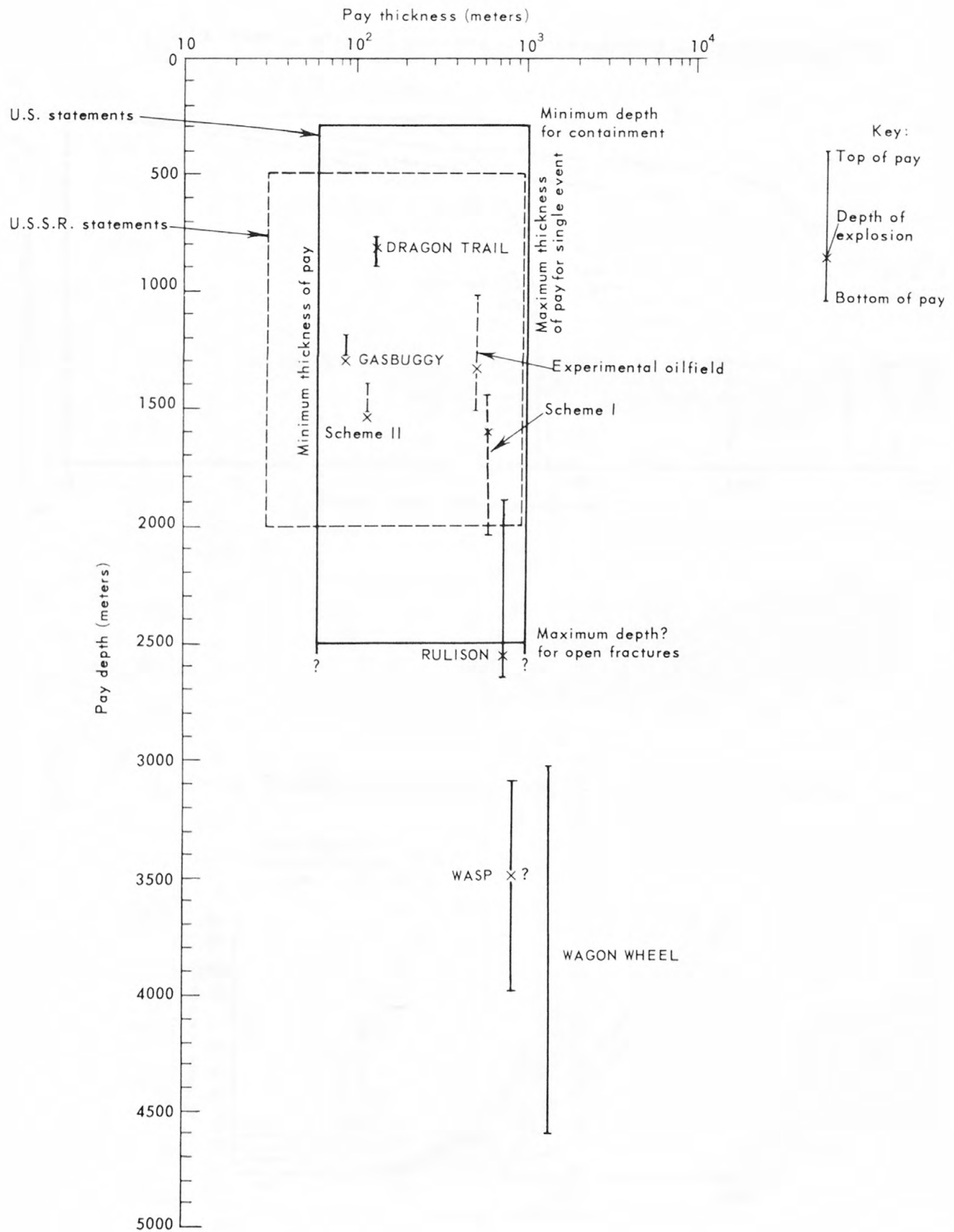

Figure 12. Reservoir geometry and petroleum-stimulation amenability

Figure 13. Heating effects of contained nuclear explosions (After Heckman, 1964)

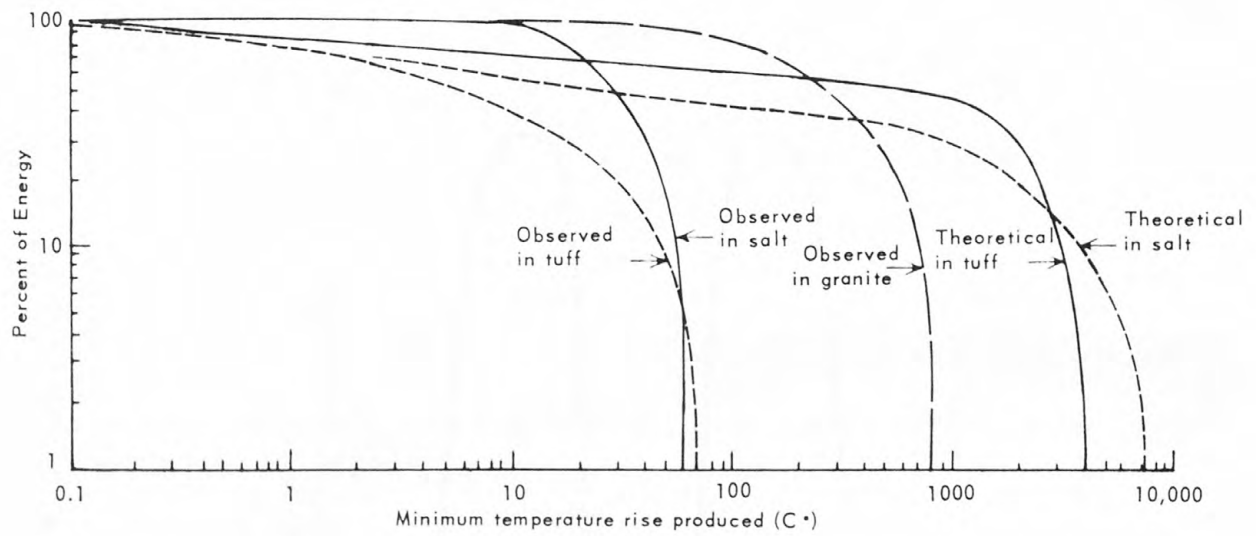
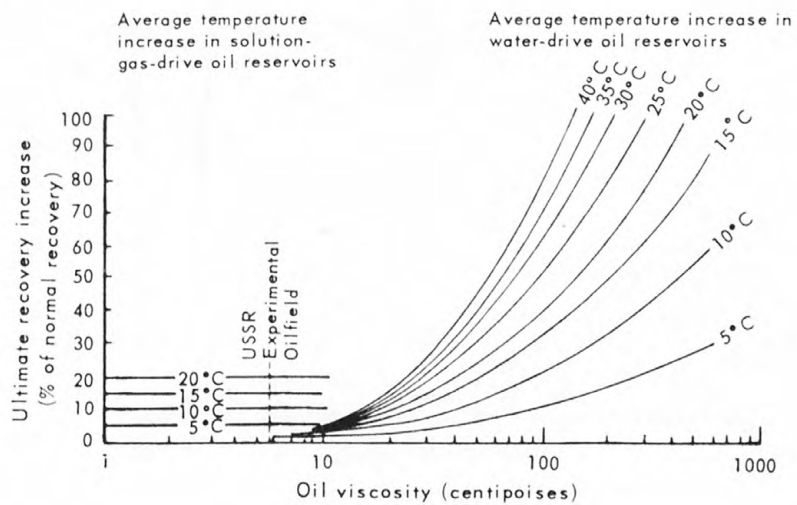

Figure 14. Petroleum stimulation by heating (After Atkinson and Johansen, 1964)



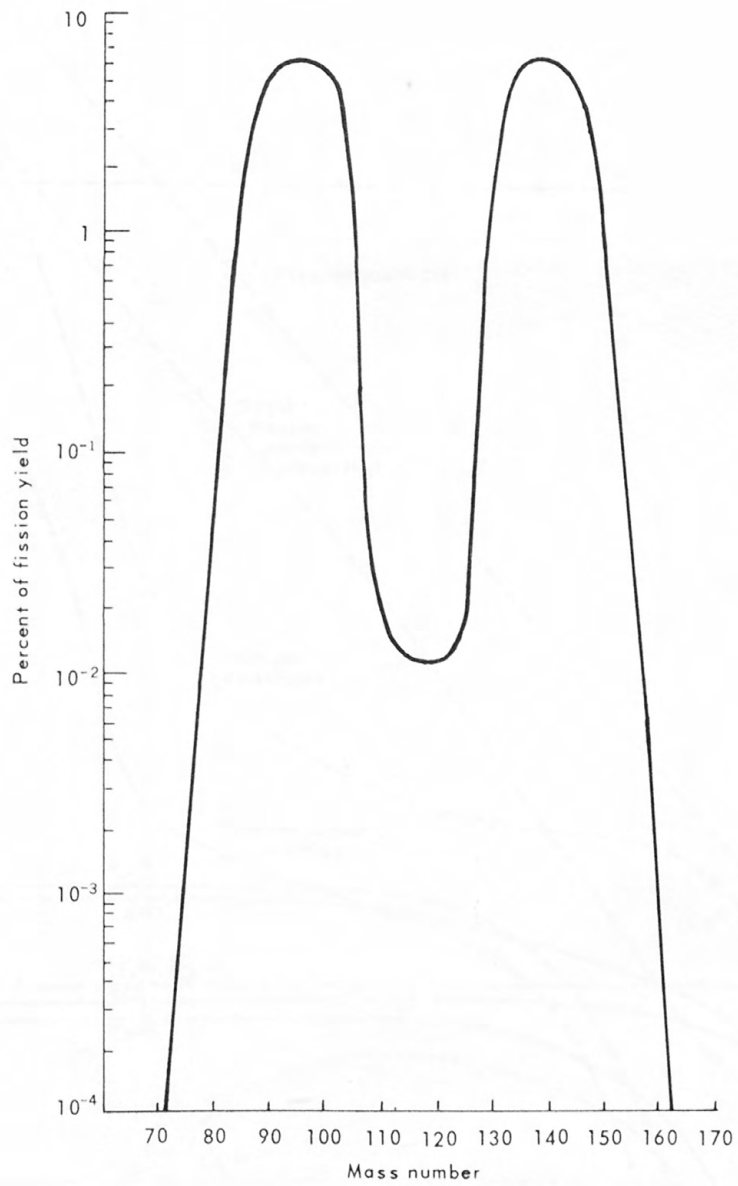
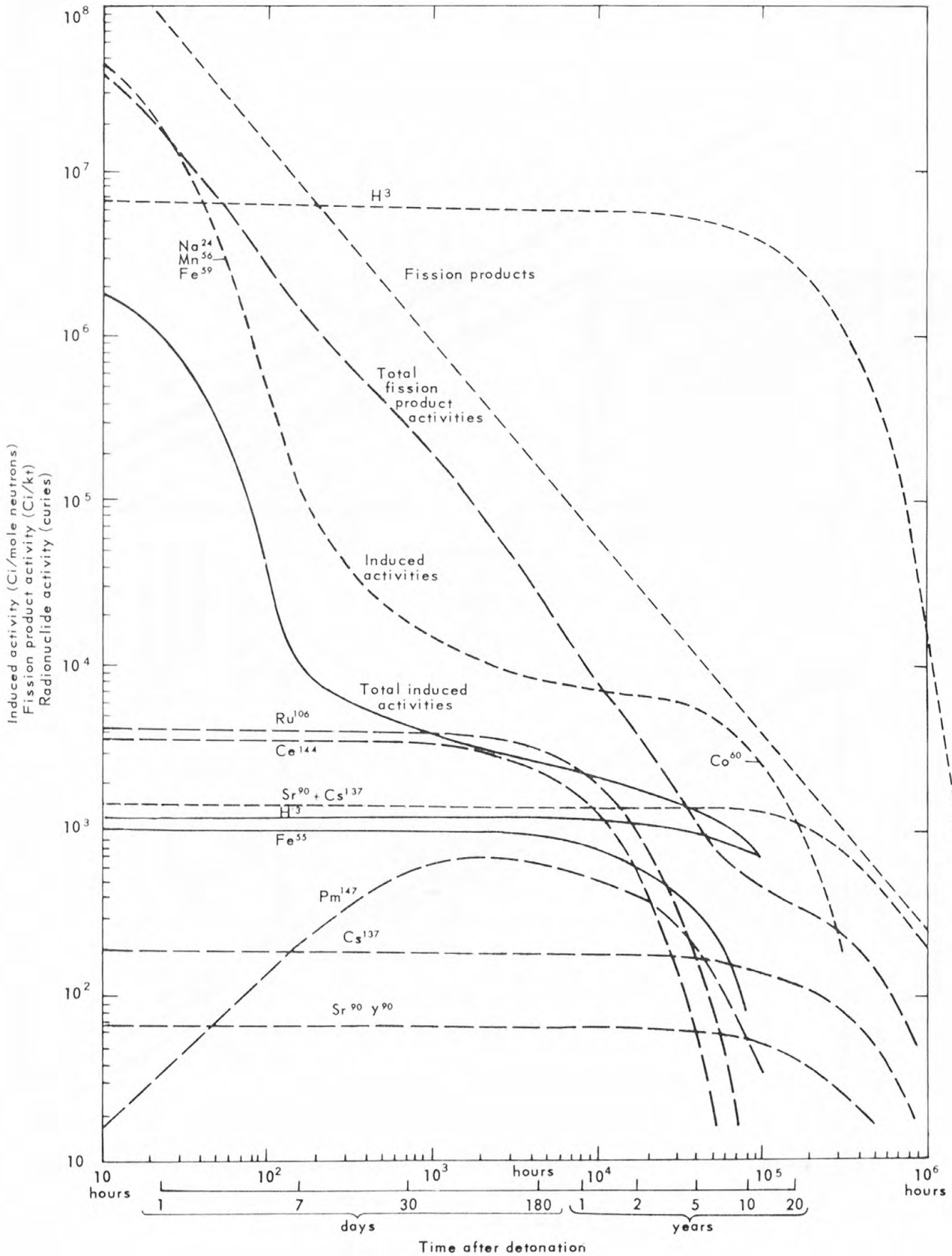

Figure 15. Yield-mass curve for thermal fission of  $U^{235}$   
(From Miskel, 1964)

Figure 16. Radioactivity and time after detonation

- Radionuclides from nominal mt fission-fusion explosion in average crustal material (From Stead, 1964)
- Fission product activity per kilotons of fission energy (From Hughes, 1968)
- Induced activity in wet shale medium (From Hughes, 1968)



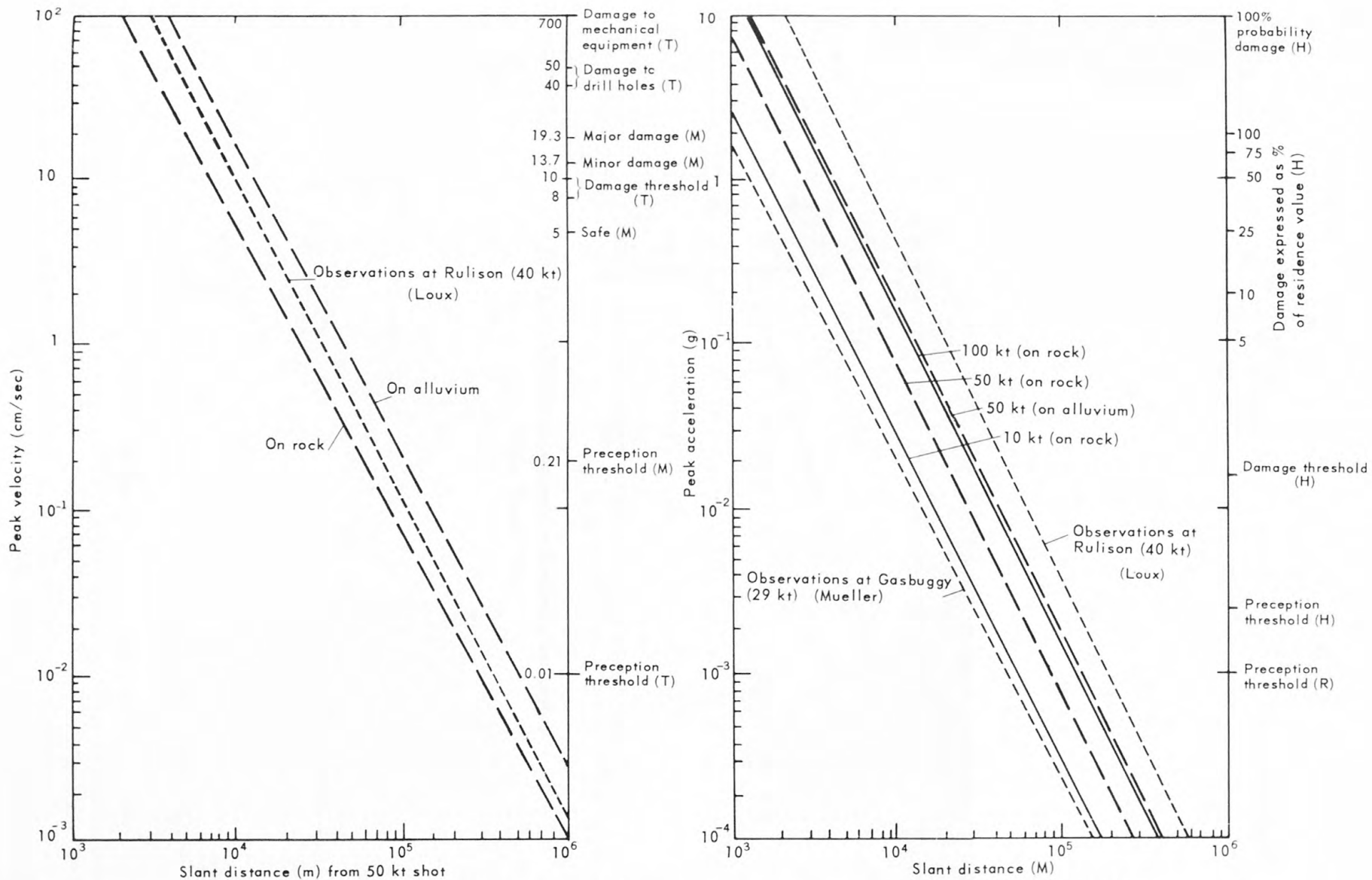

Figure 17. Predicted peak surface particle motion versus slant distance (From Kinnamon et al, 1967)  
 Damage evaluations from (R) Richter, 1958; (M) Mickey, 1964; (H) Hughes, 1968; (T) Teller et al, 1968  
 Observed motion from Mueller, 1970, and Loux, 1970

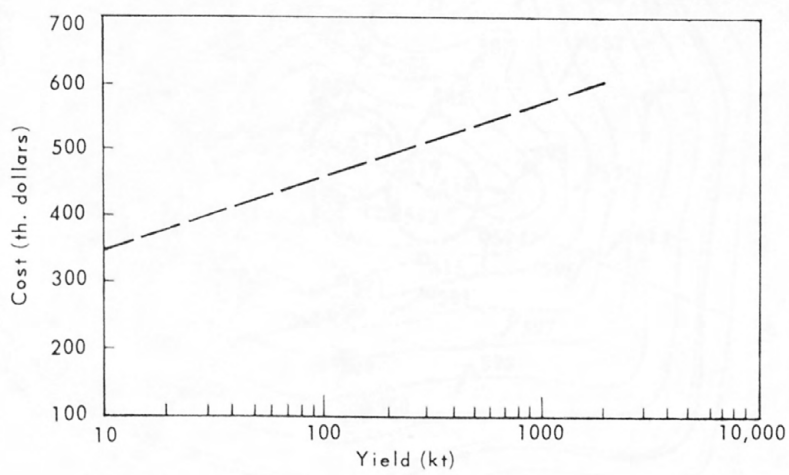

Figure 18. Projected charges for thermonuclear explosives  
(After Frank, 1964)

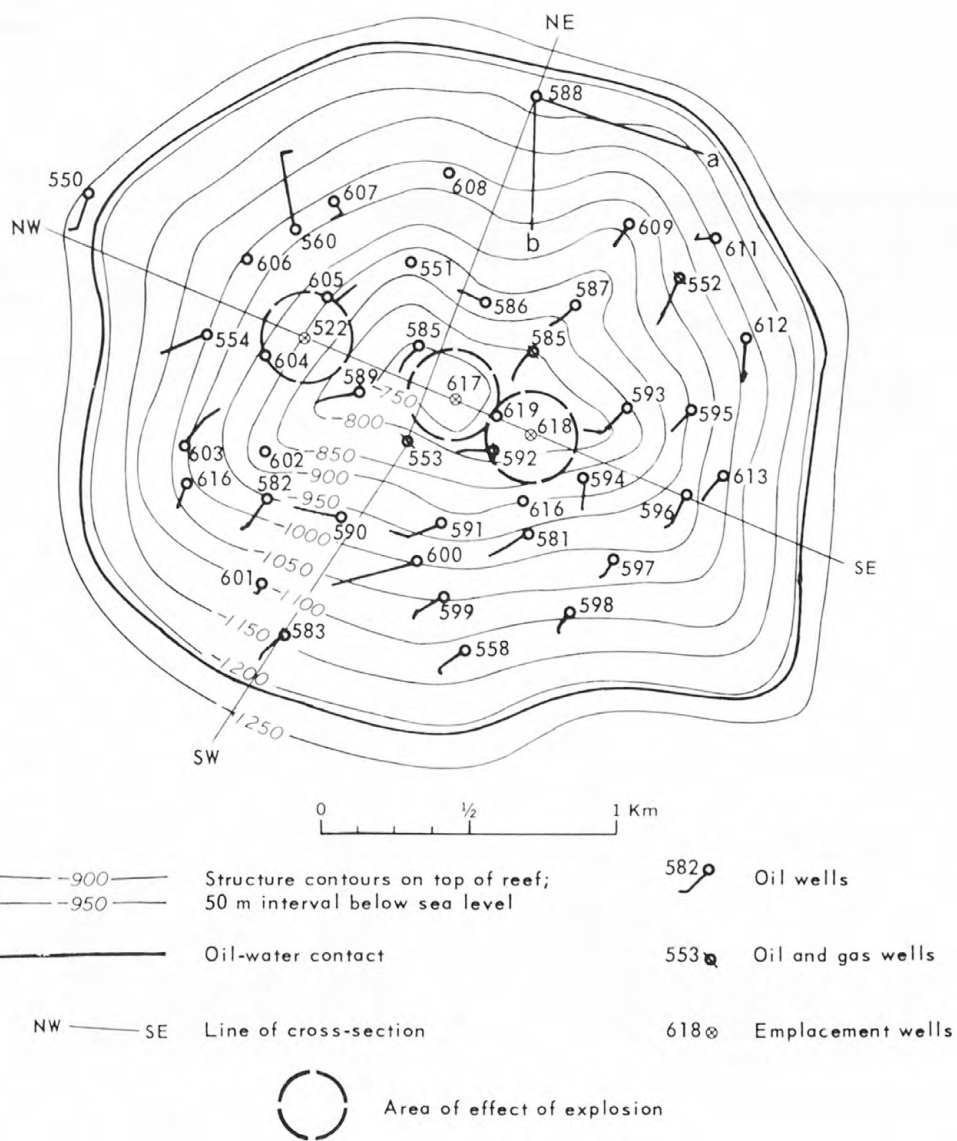
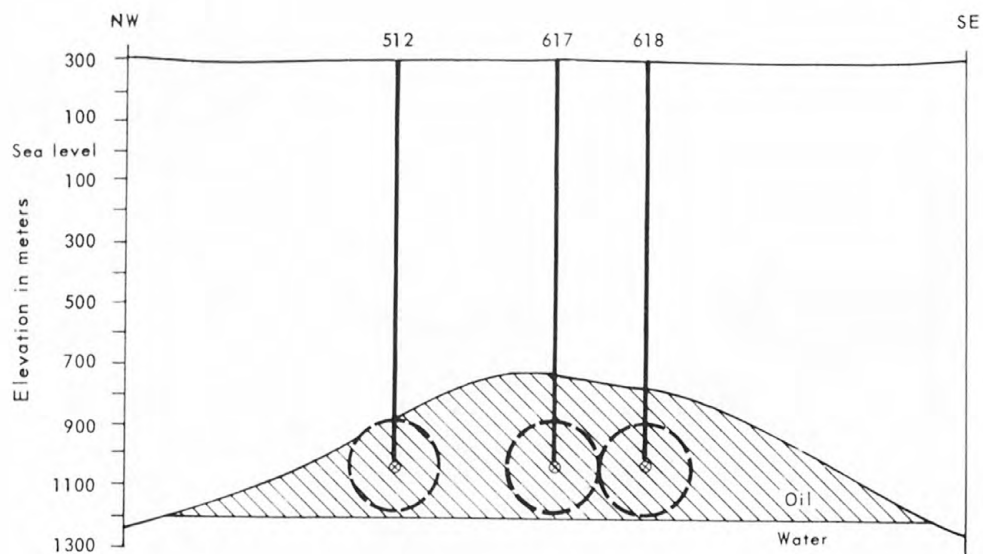
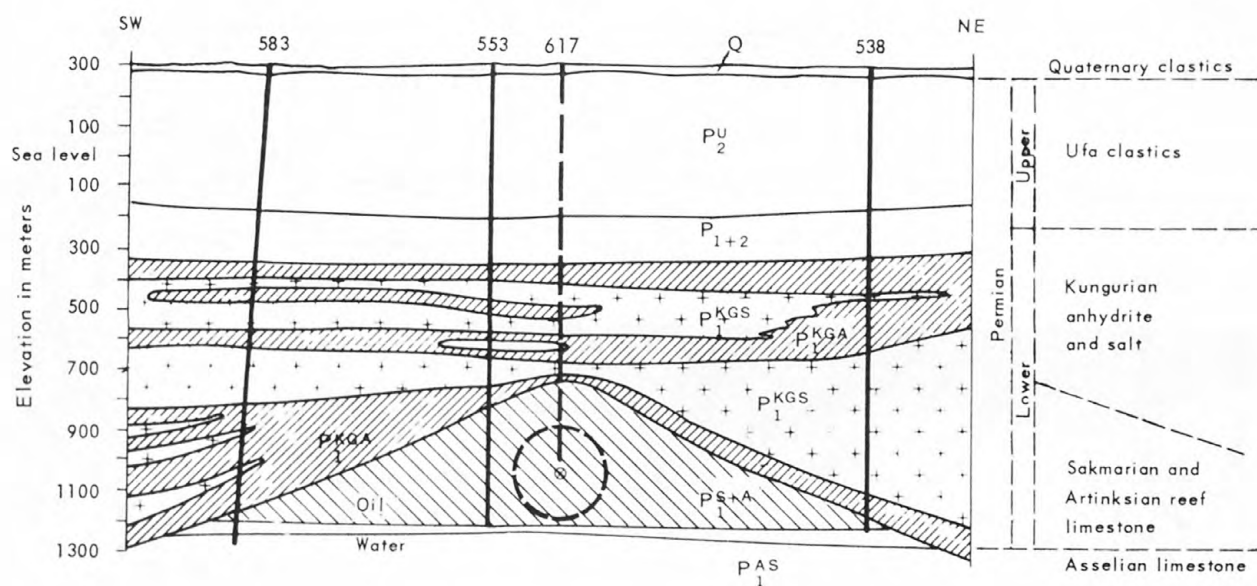

Figure 19. Subsurface geology of experimental oilfield site (After Kedrovskiy, 1970)



Scale approx. 1:25,000; no vertical exaggeration

0 1/2 1 Km

Figure 20. Cross sections of experimental oilfield site  
(After Kedrovskiy, 1970)

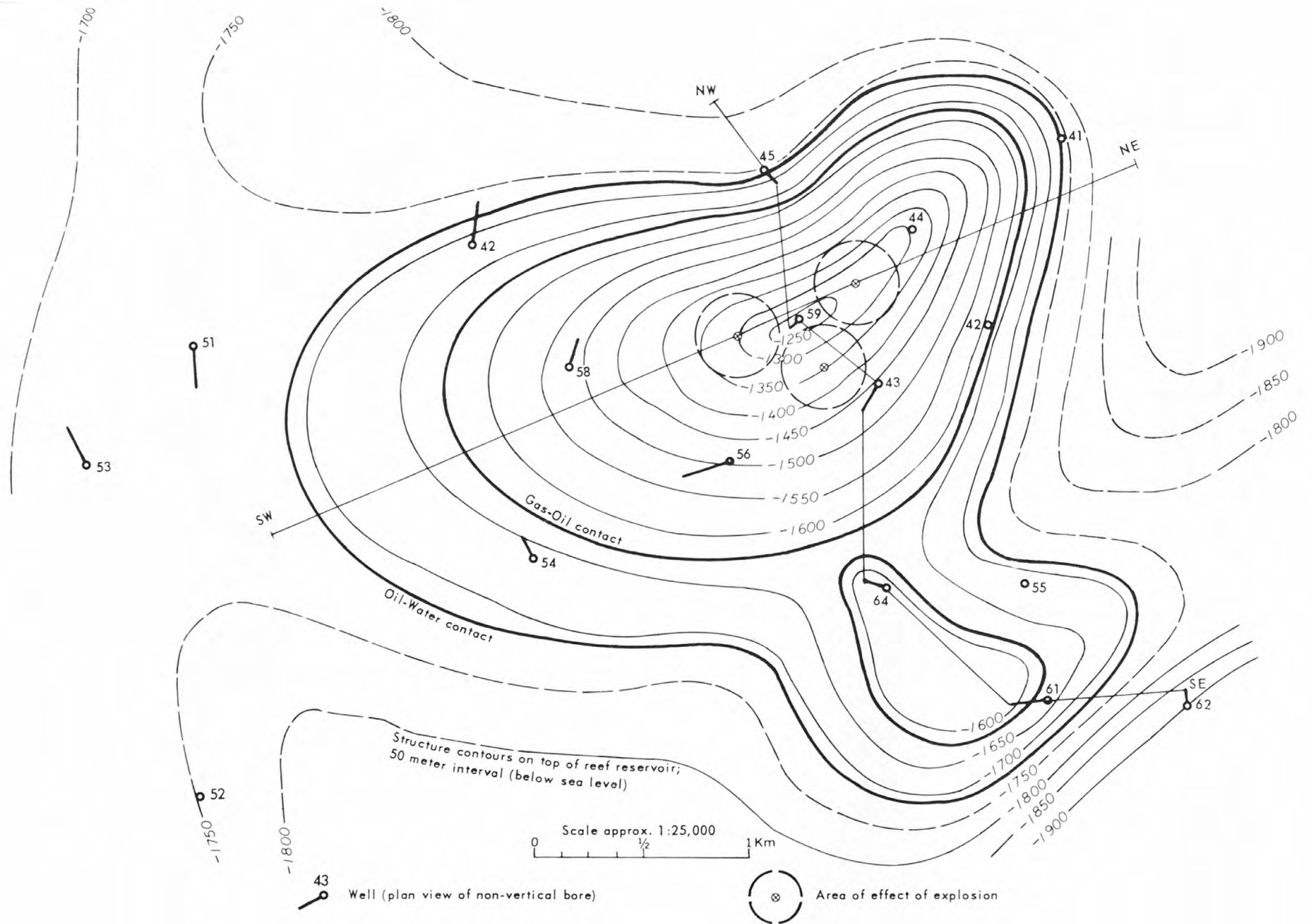

Figure 21. Subsurface geology of gasfield project site - Scheme I (After Kedrovskiy, 1970)

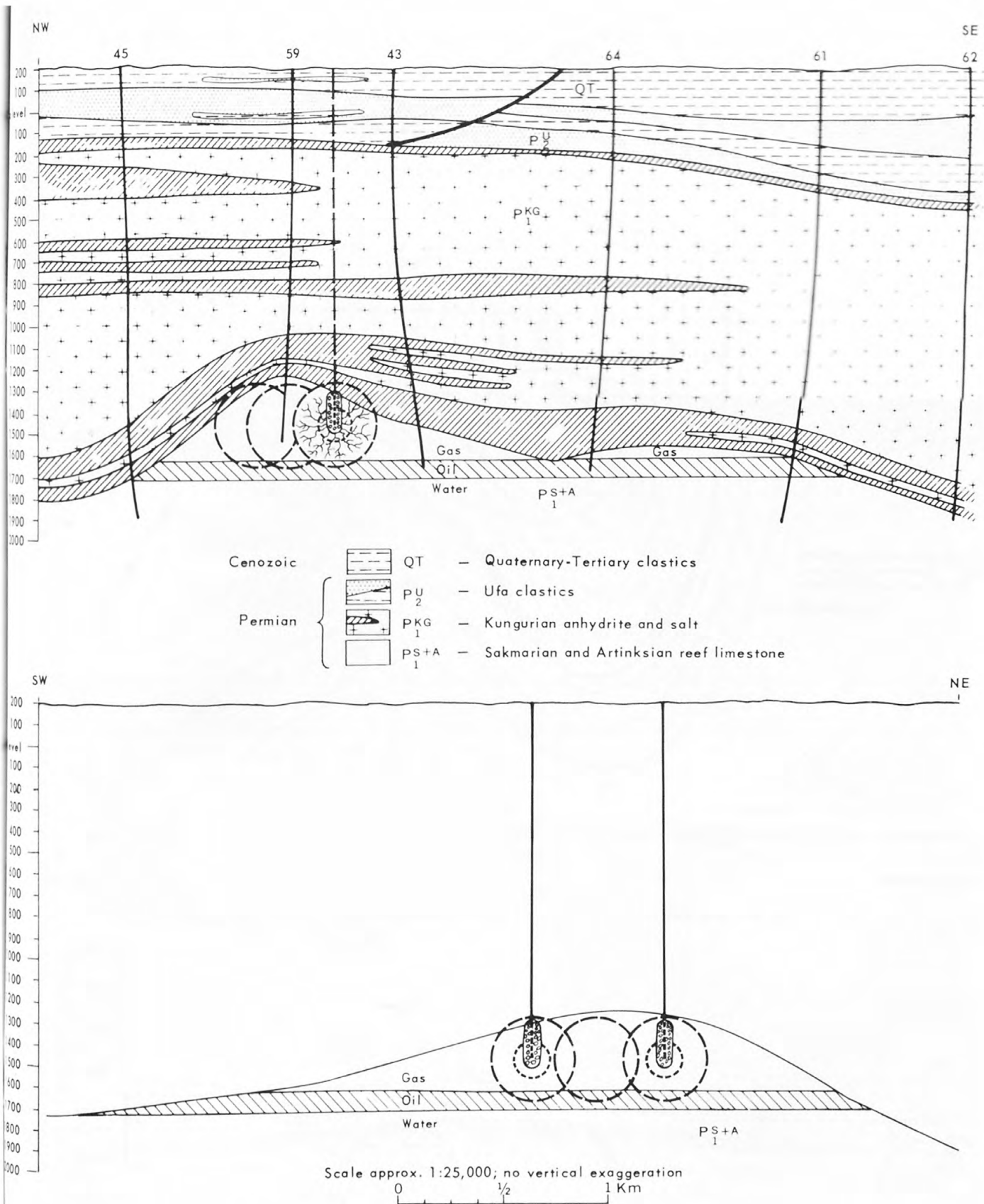

Figure 22. Cross-sections of gasfield project site - Scheme I  
(After Kedrovskiy, 1970)

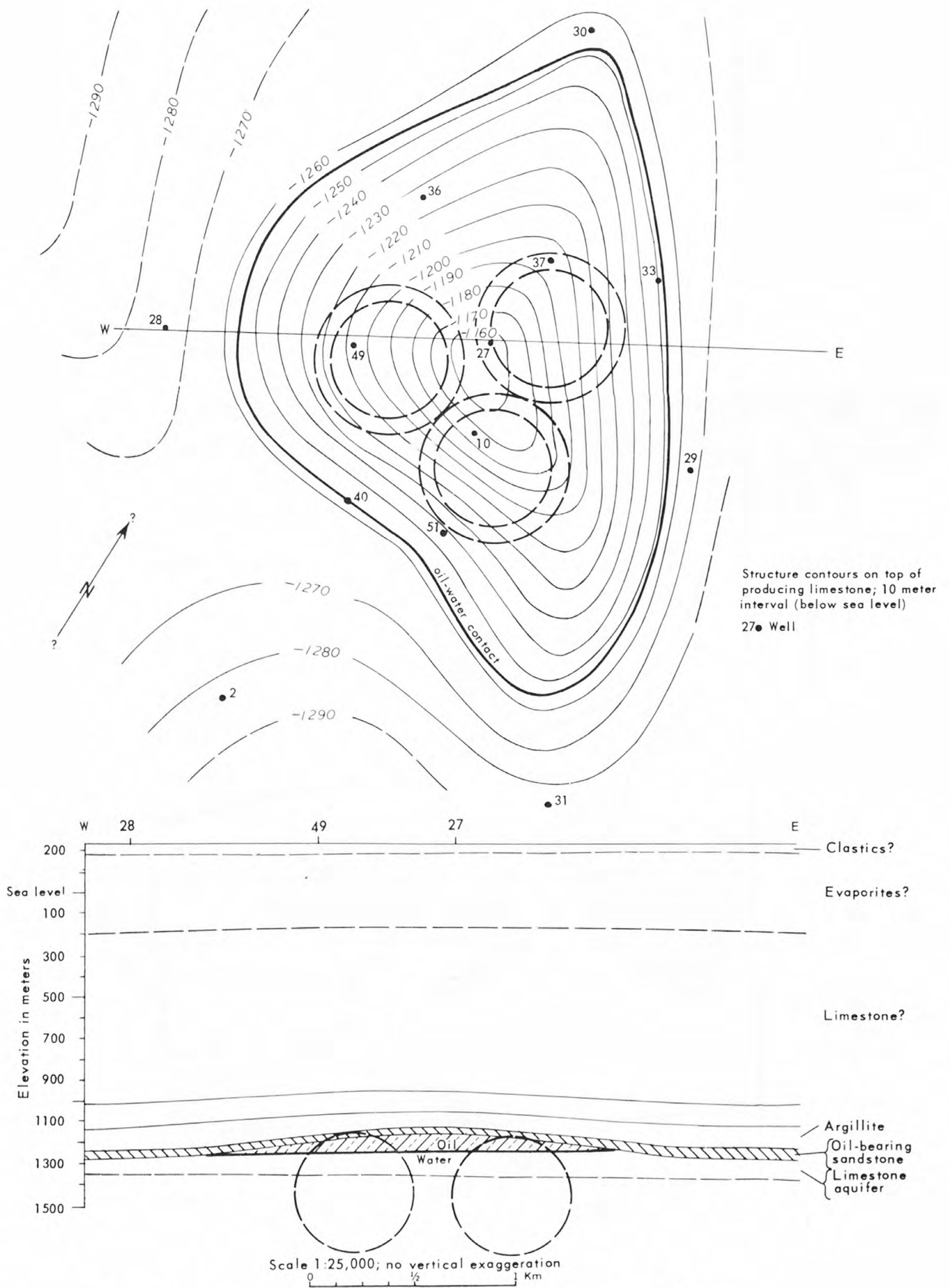

Figure 23. Subsurface geology of water-drive oilfield project site - Scheme II  
(After Kedrovskiy, 1970)

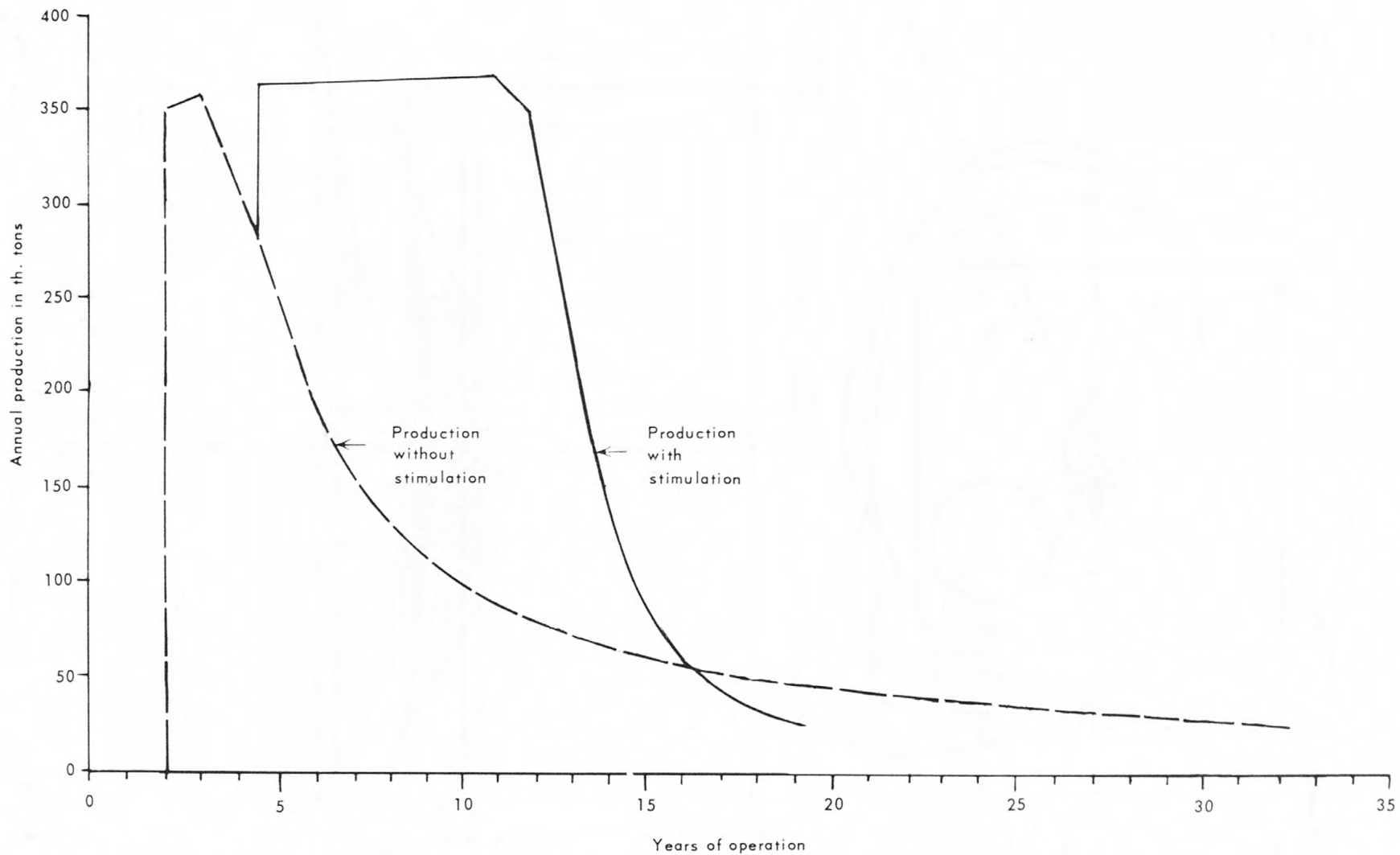
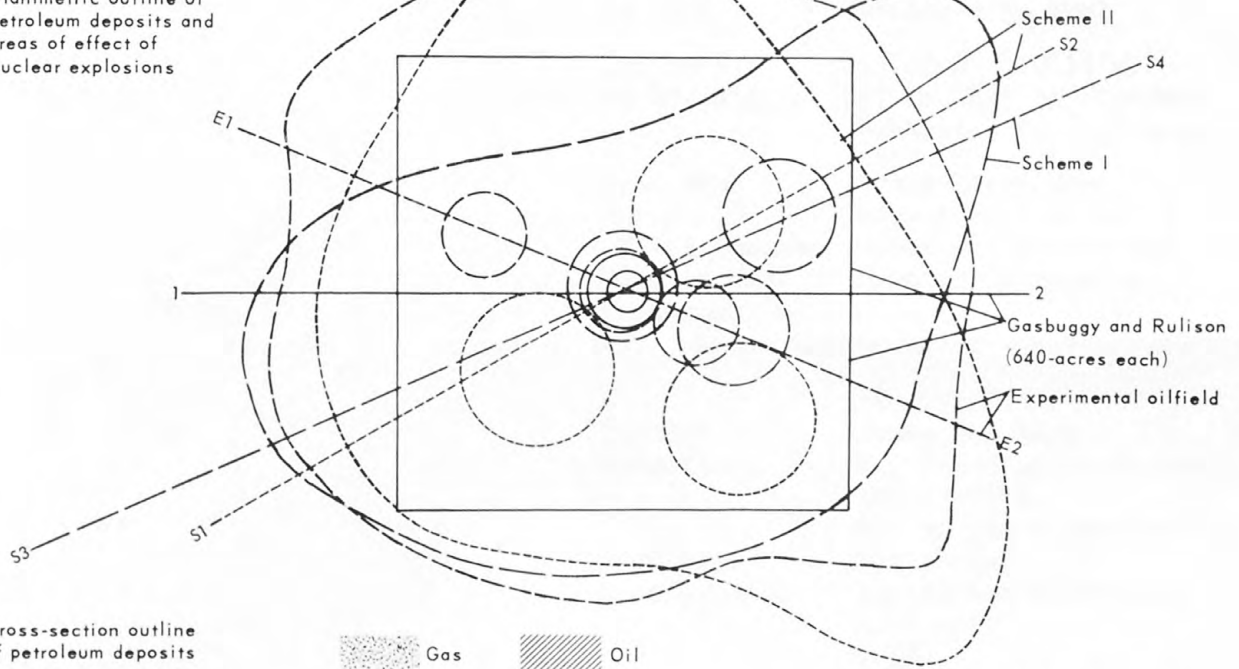

Figure 24. Production history of water-drive oilfield project site - Scheme II (After Kedrovskiy, 1970)

Figure 25. Three-dimensional comparison of petroleum-stimulation projects

A. Planimetric outline of petroleum deposits and areas of effect of nuclear explosions



B. Cross-section outline of petroleum deposits

Gas Oil

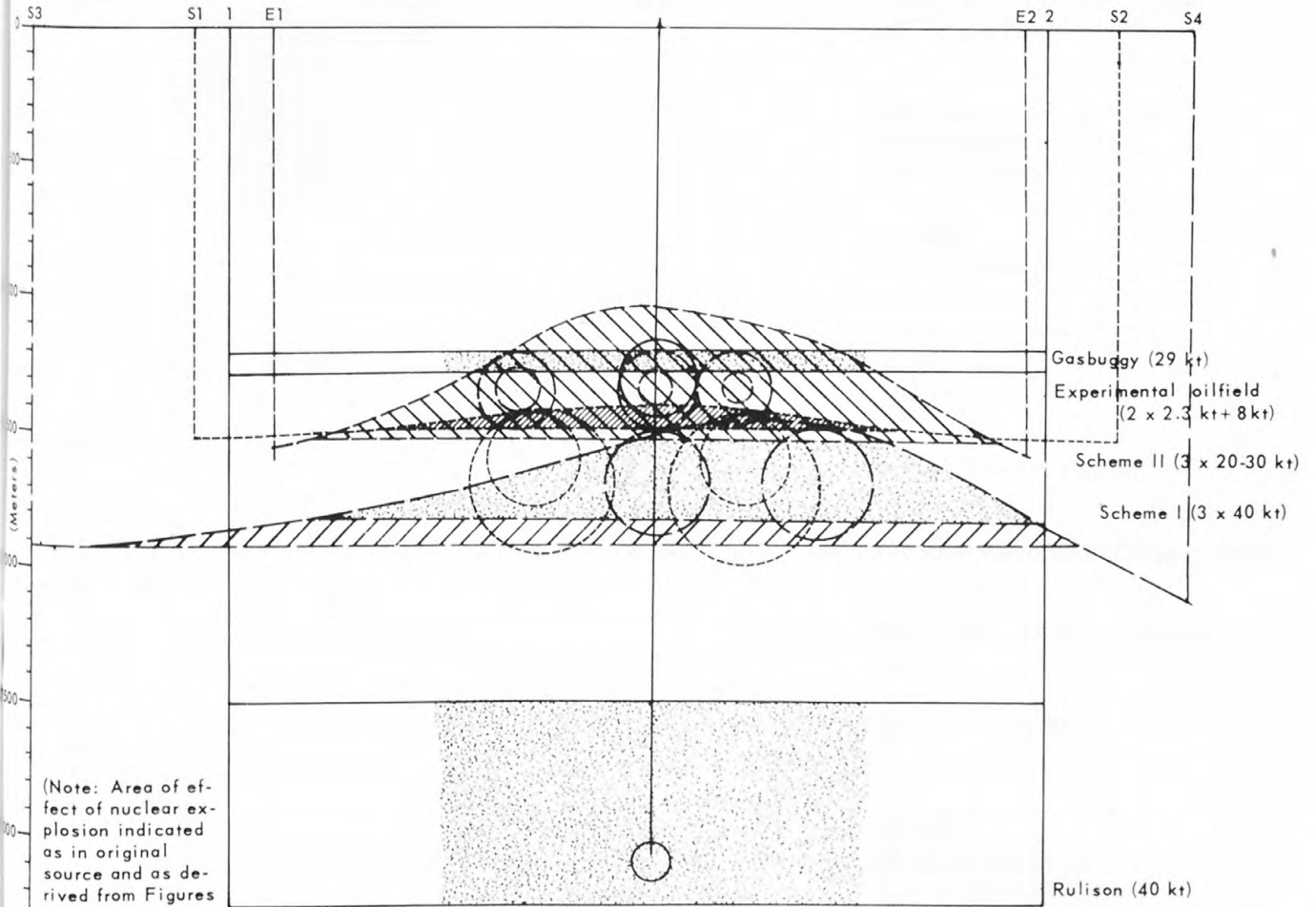

(Note: Area of effect of nuclear explosion indicated as in original source and as derived from Figures 2 and 3 and Table 3)

Scale 1:25,000; no vertical exaggeration  
0 1 Km

Table 1. Environmental data at U. S. sites for petroleum-stimulation Flowshare projects

Project	Gasbuggy	Rulison	Dragon Trail	WASP (Wagon Wheel has similar environment)
Date of Event	10 December 1967	10 September 1969	Proposed in 1966	Proposed in 1957
Geographic Location	36°40'40"N. 107°12'30"W., 112 km E. of Farmington, New Mexico	39°24'21"N. 107°56'53"W., 10 km SE. of Grand Valley Garfield Co., Colorado	39°52'N. 108°49'W., 27 km S. of Rangely, Colorado	43°00'N. 110°17'W. 37 km WNW. of Pinedale Sublette, Co., Wyoming
Geologic Setting	San Juan Basin: 3,000 to 4,500 m of Cambrian to Tertiary sediments.	Piceance Creek Basin: on SW. flank of basin containing more than 6,000 m of Cambrian to Quaternary sediments.	Douglas Creek Arch between Piceance Creek and Uinta Basins: about 3,000 m of Cam- brian to Quaternary sediments.	Green River Basin: more than 6,000 m of Upper Cretaceous and Tertiary sediments.
Reservoir Rock:				
-identification	Upper Cretaceous Pictured Cliffs formation	Upper Cretaceous Mesaverde formation	Upper Cretaceous Mancos B formation	Lower Tertiary Ft. Union-Lance formation
-depth	1194-1281 m	1880-2650 m (2225-2580)	775-900 m	3100-3970 m
-thickness	87 m; 47 m gas-bearing	770 m (335 m); 115 m gas	100 + m	870 m; 320 m gas-bearing
-dip	horizontal	slight dip (<5°) to NE.	near crest of arch	horizontal
-lithology	shales and sandstones	shales and sandstones	shales and sandstones	shales and sandstones
-density	2.48 g/cc	2.67 g/cc	2.38 g/cc	2.68 g/cc
-porosity	11.8%	9.7%	12.7%	8.5%
-permeability	0.14 md (core); 0.01- 0.02 md (in situ)	0.11-0.5 md (core); 0.008 md (in situ)	1.3 md (sand lenses)	0.245 md (core); 0.06 md (in situ)
Hydrocarbon Deposit:				
-area of structure	160 acres (2.5 ± km <sup>2</sup> )	160 acres (2.5 ± km <sup>2</sup> )	160 acres (2.5 ± km <sup>2</sup> )	160 acres (2.5 ± km <sup>2</sup> )
-closure	horizontal	pinches out to N.	pinches out to E.	horizontal
-formation pressure	74-88 kg/cm <sup>2</sup>	183-206 kg/cm <sup>2</sup>	63 kg/cm <sup>2</sup>	565 kg/cm <sup>2</sup>
-gas factor	--	--	--	--
-water saturation	58%	45% (38-55%)	37%	39-45%
-drive mechanism	depletion	depletion	depletion	depletion
-specific gravity	0.673	0.625		
-temperature	55°C			
-viscosity	0.012-0.015 cp			
-chemical nature	85% methane, 7.5% ethane; 4% propane	80% methane		
Caprock:	Fruitland and Kirkland shales; 95+ m thick	Green River shale	Mancos shale	Green River shale
Subreservoir Rock:	Lewis shale; 495 m thick	Mancos shale	Mancos shale	Mesaverde and Mancos shales
Production Data:				
-discovery date	1955; 8 wells nearby	1962; 9 test wells		1947-49; 16 deep wells
-average daily prod.	2076 m <sup>3</sup> (7788 initial)	2830-4250 m <sup>3</sup>	2830 m <sup>3</sup>	110 m <sup>3</sup>
-average annual prod.	231x10 <sup>3</sup> m <sup>3</sup> /ha			
-reserves	24.5x10 <sup>5</sup> m <sup>3</sup> /ha	120x10 <sup>5</sup> m <sup>3</sup> /ha		675x10 <sup>6</sup> m <sup>3</sup> /ha
Explosion Data:				
-depth	1,292 m	2,568 m	820 m	3,500 m
-yield	29 ± 3 kt	40 ± 20 4	40 kt	50 kt
-cavity radius	26 ± 2 m	27.5 m predicted	33 m predicted	28 m predicted
-chimney height	101.5 m	114.6 m predicted	129 m predicted	136 m predicted
-extent of fracturing	135-230 m	119-177 m predicted	82-200 m predicted	100-160 m predicted
-post-shot permeability	0.005-0.05 md in situ			
-post-shot production	25.5x10 <sup>5</sup> m <sup>3</sup> in 20 years		6 to 8x	

Table 2

Contained nuclear explosions in typical petroleum reservoir rocks

(Data from Boardman, 1970, unless otherwise specified)

Rock			Dolomite	Clastics: shale, sandstone	
Project			Handcar	Gasbuggy	Rulison
Date			5 Nov. 64	10 Dec. 67	10 Sept. 69
Item	Symbol	Units			
Shot point depth	h	m	402.3	1292	2573 $\neq$
Explosive energy	W	kt	12 $\pm$ 1	29**	40
Cube-root energy	W <sup>1/3</sup>	-	2.29	3.07	3.42
Scaled depth	h/W <sup>1/3</sup>	-	176	422	753
Cavity radius	R <sub>c</sub>	m	20.7	26 $\pm$ 2	(27.5)#
R <sub>c</sub> /W <sup>1/3</sup>	C <sub>c</sub>	-	9.0	8.5	(8.1)#
Chimney radius	R <sub>ch</sub>	m	25.0	n.a.	n.a.
R <sub>ch</sub> /R <sub>c</sub>	-	-	1.2	n.a.	n.a.
Chimney height	H <sub>ch</sub>	m	68.0	101.5	(114.6)#
H <sub>ch</sub> /R <sub>c</sub>	-	-	3.3	3.9	(5.3)#
Fracturing radius	R <sub>f</sub>	m	70 $\neq$	135-230**	(148)#
R <sub>f</sub> /R <sub>c</sub>	-	-	3.4 $\neq$	5.2-9.0**	(3.7)#
R <sub>f</sub> /W <sup>1/3</sup>	-	-	31 $\neq$	44-75**	(43)#
Fracturing height	H <sub>f</sub>	m	135 $\pm$ 32	(120)*	n.a.
H <sub>f</sub> /R <sub>c</sub>	-	-	6.2 $\pm$ 1.5	(4.6)*	n.a.
Chimney voids	l	%	13	25	n.a.
Void volume	V <sub>ch</sub>	m <sup>3</sup> x 10 <sup>3</sup>	37.1 $\pm$ 3.7	73.6	(86.3)#
V <sub>c</sub> /W	-	m <sup>3</sup> x 10 <sup>3</sup> / kt	3.09	2.5	(2.2)#
Rubble volume	V <sub>r</sub>	m x 10	87.7	201	(271)#
Temperature	T	°C	50 $\pm$ $\neq$	100-150 $\neq$	n.a.

n.a. - not available

\* -- predictions in Holzer, 1967

\*\* - reported in Holzer, 1970

# - E.R.C. predicted means in U.S. Atomic Energy Commission, 1969

 $\neq$  - reported in Higgins, 1970

Long-lived radionuclides significant in petroleum-stimulation projects

Radionuclide	Half-life (years)	MPC* (ci/ml)	Case 1 (curies)	Case 2 (ci/ml)	Case 3 (ci/ml)	Case 4 (ci/ml)	Case 5 (ci/ml)	Case 6 (ci/ml)	Case 7 (curies)	
Fusion product	H 3	12.26	$3 \times 10^{-8}$	$6.7 \times 10^6$	$4.8 \times 10^{-6}$	$4.5 \times 10^{-7}$	$1 \times 10^{-10}$	$1.8 \times 10^{-12}$	$5.7 \times 10^{13}$	$10^3$ to $10^4$
	C14	5570	$9 \times 10^{-13}$	15	n.a.	n.a.	$2 \times 10^{-15}$	n.a.	n.a.	$10^{-1}$ to $10^{-2}$
Neutron-activation products	A39	260	n.a.	n.a.	n.a.	n.a.	n.a.	n.a.	n.a.	2 to 20
	Co60	5.2	$5 \times 10^{-10}$	$1 \times 10^4$	$1.3 \times 10^{-12}$	$1.2 \times 10^{-12}$	n.a.	n.a.	n.a.	n.a.
	Kr85	10.76	$3 \times 10^{-12}$	n.a.	n.a.	n.a.	$1 \times 10^{-13}$	$7.1 \times 10^{-14}$	$1.1 \times 10^{-13}$	$9.6 \times 10^2$
Fission products	Sr90	28.8	$1 \times 10^{-12}$	$1.5 \times 10^3$	$2.0 \times 10^{-12}$	$1.8 \times 10^{-13}$	n.a.	n.a.	n.a.	$5.9 \times 10^3$
	Cs137	30.0	$1 \times 10^{-10}$	$1.6 \times 10^3$	n.a.	n.a.	n.a.	n.a.	n.a.	$7.5 \times 10^3$

\* - MPC (maximum permissible concentration) in drinking water for occupational workers continuously exposed (168-hour week). (Note: n. a. - not available)

Case 1: 1 megaton (1% fission, 99% fusion) contained explosion in neutron-capturing materials assumed to be average crustal composition with 20% saturated porosity (Stead, 1964)

Case 2: 1 megaton (as above) in dolomite rock with 5% saturated porosity (Stead, 1964)

Case 3: 1 megaton (as above) in tuff or alluvium with 30% saturated porosity (Stead, 1964)

Case 4: 10 to 100 kilotons in clastic gas reservoir; 1 year after explosion (Higgins and Rodean, 1965)

Case 5: 10 kilotons in clastic gas reservoir with 11% porosity (59% water-saturated) (Bonner, 1965)

Case 6: 29 kilotons in clastic gas reservoir at Gasbuggy site; 1 month after detonation (AEC announcement)

Case 7: 40 kilotons in clastic gas reservoir at Rulison site; predicted total radionuclides remaining after 180 days (US, AEC, 1969)

Table 6  
Costs in the Rulison project area  
 (After Frank and others, 1970; in thousands of dollars)

<u>Item</u>	<u>Rulison shot</u>	<u>Proposed new shot</u>
Feasibility	77	0
Exploratory wells and testing	1,089	0
Site studies	875	10
Operational plan; government contract	162	20
Site preparation	194	100
Explosive services	658*	200*
Explosive operations	276	140
Operational safety	656	80
Seismic documentation and damage	278	60
Production	300	50
Project management	299	30
Public information	<u>103</u>	<u>10</u>
Subtotal (excluding drilling costs)	4,967	700
Emplacement hole	754	**
Reentry hole	<u>230</u>	**
Total cost	5,951	

\* Explosive services charges listed for the Rulison shot and the proposed new shot should not be construed to reflect accurate values for Rulison or accurate estimates of capabilities to reduce the cost of future devices which might be utilized in the proposed new shot.

\*\* Not yet determined; can vary significantly.

Table 7: Environmental data at U.S.S.R. sites for petroleum-intensification projects  
(Data from U.S.S.R., SCAE, 1969, and Kedrovskiy, 1970)

Project	Experimental Oilfield	Scheme I	Scheme II
Nature of Project	Conducted before 1969 within producing field for phenomenology and intensification; 13 km to town (20,000 pop.).	Proposes 3 explosions within producing gasfield for intensification and to shorten exploitation time.	Proposes 3 explosions within small producing oilfield for intensification by increasing water drive.
Geologic setting	Permian basin margin with isolated reefs covered by thick Kungurian saline and Ufian clastic deposits.	Similar to experimental oilfield.	Paleozoic platformal sequence with carbonate, clastic, and saline deposits.
Reservoir Rock:			
-identification	Lower Permian (Artinskian-Sakmarian) reef.	Lower Permian (Artinskian-Sakmarian) reef	Probably Carboniferous limestone formation
-depth	>1050 m	>1450 m	>1400 m
-thickness	up to 500 m	up to 600 m	about 120 m
-structure	circular dome	double dome	triangular dome
-lithology	biohermal limestone with irregular porosity	biohermal limestone with irregular porosity	carbonate with dense interlayers
-porosity	0.5-35%; average 7%		
-permeability	3-100 md; average 25-30 md		
Hydrocarbon Deposit:			
-area of structure	about 3.5 km <sup>2</sup>	about 2.5 km <sup>2</sup> (gas)	about 3 km <sup>2</sup>
-closure	460± m	380+ m (gas); 85 m (oil)	100± m
-elevation of base	-1210 m	-1625 m (gas); -1710 (oil)	-1255 m
-formation pressure	137 down to 30 kg/cm <sup>2</sup>		
-gas factor	maximum 250 m <sup>3</sup> /ton		
-water saturation	20%		
-drive mechanism	depletion and water	depletion and water	water
-specific gravity	0.860		
-temperature	23°C		
-viscosity	6 cp		
-chemical nature	6% sulphur	85 m oxidized oil at base	
Caprock:	Kungurian saline deposits; 400-1070 m thick	Kungurian saline deposits; 1100-1500 m thick	Clayey carbonate beds; 90-150 m thick
Subreservoir Rocks:	Thick carbonate beds	Thick carbonate beds	Carbonate beds 70-200 m thick
Production Data:			
-years of production	8 when detonated		Proposed for 5th
-average daily prod.		250,000 m <sup>3</sup>	
-average annual prod.			350,000 tons maximum
-reserves	>1 billion tons		
Explosion Data:			
-depth	1,340 m	1,600 m	>1,500 m
-yield	2x2.3 kt + 8 kt	3x40 kt	3x20-30 kt
-extent of fracturing	150-250 m	270 m	250 m
-post-shot production	up to 60% greater per month; final recovery percentage increased	3x10 <sup>6</sup> m <sup>3</sup> /day or about 10x; exploitation time shortened by 11x; 5-6 million rubles saving	>350,000 tons/year for about 8 years; deplete in 15 rather than 30 years; recovery up 30%

Table 8

Extent of fracturing indicated in Soviet sources

Source	Depth (m)	Yield (kt)	Cavity radius (m)*	Fracture radius (m)	Fracturing ratios $R_f/R_c$ $R_f/W^{1/3}$	
Mangushev and Zolotovitskaya (1969); minimum example	1,500+	20	24.3	150	6.0	56
Mangushev and Zolotovitskaya (1969); maximum example	1,500+	50	33.3	250	7.5	68
Kedrovskiy (1970); Scheme I	1,600	40	30.6	270	8.8	80
Kedrovskiy (1970); Scheme II	1,500+	30	27.9	250	8.9	80
Kedrovskiy (1970); Experimental oilfield	1,340	2x2.3 8	11.7 18.0	150- 250?	8.3- 14	75- 125

\* Cavity radius calculated by  $R_c = W^{1/3} C_c$  with lithologic constant,  $C_c$ , assumed to be 9.





USGS LIBRARY RESTON



3 1818 00060369 4