

Relations of Tualatin River Water Temperatures to Natural and Human-Caused Factors

U.S. GEOLOGICAL SURVEY
Water-Resources Investigations Report 97-4071

Prepared in cooperation with the
UNIFIED SEWERAGE AGENCY OF WASHINGTON COUNTY, OREGON



Cover photograph. Low-head diversion dam on Tualatin River near West Linn (photograph by Stewart A. Rounds, U.S. Geological Survey).

Relations of Tualatin River Water Temperatures to Natural and Human-Caused Factors

U.S. GEOLOGICAL SURVEY
Water-Resources Investigations Report 97-4071

Prepared in cooperation with the
UNIFIED SEWERAGE AGENCY OF WASHINGTON COUNTY, OREGON



Relations of Tualatin River Water Temperatures to Natural and Human-Caused Factors

By John C. Risley

U.S. GEOLOGICAL SURVEY
Water-Resources Investigations Report 97-4071

Prepared in cooperation with the
UNIFIED SEWERAGE AGENCY OF WASHINGTON COUNTY, OREGON



Portland, Oregon
1997

U.S. DEPARTMENT OF THE INTERIOR
BRUCE BABBITT, Secretary

U.S. GEOLOGICAL SURVEY
Gordon P. Eaton, Director

Any use of trade, product, or firm names in this publication is for descriptive purposes only and does not imply endorsement by the U.S. Government.

For additional information contact:

District Chief
U.S. Geological Survey, WRD
10615 S.E. Cherry Blossom Drive
Portland, OR 97216-3159
E-mail: info-or @ usgs.gov
Internet: <<http://oregon.usgs.gov>>

Copies of this report can be
purchased from:

U.S. Geological Survey
Branch of Information Services
Box 25286, Federal Center
Denver, CO 80225-0046

CONTENTS

Abstract	1
Introduction	1
Background	1
Purpose and Scope	3
Acknowledgments	3
Description of the Study Area	4
Physical Setting	4
Climate	4
Hydrology	4
Flow Management	5
Data Collection	6
Fixed-Station Continuous-Monitoring Sites	6
Water Temperature	6
Streamflow	8
Meteorological	8
Synoptic Water-Temperature Surveys	8
Channel Cross-Section Measurements	8
Riparian Shading Measurements	9
Description of the Computer Models	10
Computation of Shading Coefficients	11
Algorithms	11
Data Requirements	11
Upper Stream Section Modeling	11
Algorithms	11
Data Requirements	12
Lower Stream Section Modeling	13
Algorithms	13
Data Requirements	14
Model Development and Calibration	15
Upper Stream Section Modeling	15
Flow	15
Heat Transport	17
Lower Stream Section Modeling	19
Flow	19
Heat Transport	23
Management Scenario Simulations	24
Scenario Descriptions	27
Scenario Results	30
Summary and Conclusions	52
References Cited	54
Appendix A. Riparian shade parameters	55
Appendix B. Monthly mean total shade values computed by the shade model prior to calibration	65
Appendix C. Water-temperature subroutine code of the upper stream section heat transport model	75
Appendix D. Code modifications to the lower stream section heat transport model	83
Appendix E. FLOW.IN parameter file for DAFLOW	87
Appendix F. BLTM.IN parameter file for BLTM	93
Appendix G. CE-QUAL-W2 model grid dimensions	99
Appendix H. Tables of the percentage of time the 7-day moving average of daily maximum simulated May through October 1994 water temperatures exceeds 17.8 degrees Celsius along the main stem of the Tualatin River for each scenario	107

FIGURES

1. Map showing the Tualatin River Basin, Oregon.....	2
2. Graph showing monthly distribution of daily mean streamflows in the Tualatin River at West Linn, Oregon (14207500), 1975–94	5
3. Schematic diagram showing relative positions of selected tributaries, fixed-station continuous-monitoring sites, and wastewater-treatment plants, Tualatin River Basin, Oregon, 1994.....	6
4– 5. Diagrams showing:	
4. Riparian vegetation shade parameters	9
5. Local solar and stream orientation angle measurements	10
6. Model representation of a river cross section using stacked rectangles.....	13
7. Schematic diagram showing the Diffusion Analogy Flow/Branched Lagrangian Transport Model configuration for the Tualatin River, Oregon.....	15
8– 9. Graphs showing:	
8. Observed and simulated discharge from May through October 1994 in the Tualatin River, Oregon.....	18
9. Observed and simulated water temperatures from May through November 1994 in the Tualatin River, Oregon	20
10. CE-QUAL-W2 model two-dimensional cell grid for the Tualatin River, Oregon, from river mile 38.4 to river mile 3.4	21
11. Schematic diagram showing the CE-QUAL-W2 model configuration for the Tualatin River, Oregon.....	22
12.–26. Graphs showing:	
12. Observed and simulated water temperatures from May through November 1994 in the Tualatin River, Oregon	25
13. Observed hourly water temperature at the low-head diversion dam at river mile 3.4, Tualatin River near West Linn, Oregon (14207200), from May through November 1991–94.....	31
14. Mean of the daily minimum and maximum observed air temperature at the Hillsboro Airport near Hillsboro, Oregon, from May through November 1991–94.....	32
15. Monthly mean of the 7-day moving average of daily maximum simulated and observed 1994 water temperatures for scenario 1, existing conditions	35
16. Monthly mean of the 7-day moving average of daily maximum simulated 1994 water temperatures for scenario 2, existing conditions without Unified Sewerage Agency allotted flows	36
17. Monthly mean of the 7-day moving average of daily maximum simulated 1994 water temperatures for scenario 3, “natural” conditions.....	37
18. Monthly mean of the 7-day moving average of daily maximum simulated water temperatures for scenario 4, extremes of riparian shade conditions, May through October 1994	39
19. Monthly mean of the 7-day moving average of daily maximum simulated 1994 water temperatures for scenario 5, existing conditions without the low-head diversion dam at river mile 3.4, Tualatin River, Oregon	41
20. Monthly mean of the 7-day moving average of daily maximum simulated 1994 water temperatures for scenario 6, existing conditions with tributary temperature reduction.....	42
21. Monthly mean of the 7-day moving average of daily maximum simulated 1994 water temperatures for scenario 7, existing conditions without wastewater-treatment plants	43
22. The difference between monthly mean of the 7-day moving average of daily maximum simulated 1994 water temperatures for scenario 1 and scenario 7.....	44
23. Monthly mean of the 7-day moving average of daily maximum simulated 1994 water temperatures for scenario 8, existing conditions without Unified Sewerage Agency allotted flows, lower stream section withdrawals, and wastewater-treatment plants.....	46
24. Monthly mean of the 7-day moving average of daily maximum simulated 1994 water temperatures for scenario 9, existing conditions without the low-head diversion dam at river mile 3.4 and the wastewater-treatment plants, Tualatin River, Oregon	47
25. Monthly mean of the 7-day moving average of daily maximum simulated 1994 water temperatures for scenario 10, existing conditions with tributary temperature reduction and without wastewater-treatment plants.....	48
26. The percentage of time the 7-day moving average of daily maximum simulated water temperature exceeds 17.8 degrees Celsius from May 1 through November 30, 1994, for scenarios 1 through 10	51

TABLES

1. List of U.S. Geological Survey fixed-station continuous-monitoring sites in the Tualatin River Basin, Oregon, 1994.....7
2. Irrigated acreage used to estimate water withdrawals in the upper stream section of the Tualatin River, Oregon.....17
3. Percent adjustments made to riparian shading coefficients for calibration of the upper stream section transport model, Tualatin River, Oregon21
4. Irrigated acreage used to estimate water withdrawals in the lower stream section of the Tualatin River, Oregon.....23
5. Percent adjustments made to riparian shading coefficients for calibration of the lower stream section transport model, Tualatin River, Oregon24
6. Hypothetical management scenarios, Tualatin River, Oregon28
7. Water temperature data from the low-head diversion dam at river mile 3.4 near West Linn, Oregon, 1991–94.....30
8. Air-temperature data from Hillsboro Airport near Hillsboro, Oregon.....30
9. The 7-day moving average of daily maximum simulated 1994 water temperature in degrees Celsius for each management scenario during each month averaged over the reach from river mile 63.9 to river mile 3.4, Tualatin River, Oregon.....34
10. Percentage of time the 7-day moving average of daily maximum simulated 1994 water temperature in the study reach (river mile 63.9 to river mile 3.4) exceeds 17.8 degrees Celsius for each management scenario during each month.....49
11. Percentage of time the 7-day moving average of daily maximum simulated 1994 water temperature near Dilley (river mile 58.8) exceeds 17.8 degrees Celsius for each management scenario during each month.....49
12. Percentage of time the 7-day moving average of daily maximum simulated 1994 water temperature at Golf Course Road (river mile 51.5) exceeds 17.8 degrees Celsius for each management scenario during each month.....49
13. Percentage of time the 7-day moving average of daily maximum simulated 1994 water temperature at Rood Bridge (river mile 38.4) exceeds 17.8 degrees Celsius for each management scenario during each month.....49
14. Percentage of time the 7-day moving average of daily maximum simulated 1994 water temperature at Farmington (river mile 33.3) exceeds 17.8 degrees Celsius for each management scenario during each month.....50
15. Percentage of time the 7-day moving average of daily maximum simulated 1994 water temperature at Scholls Ferry Bridge (river mile 26.9) exceeds 17.8 degrees Celsius for each management scenario during each month.....50
16. Percentage of time the 7-day moving average of daily maximum simulated 1994 water temperature at Elsner Road (river mile 16.2) exceeds 17.8 degrees Celsius for each management scenario during each month.....50
17. Percentage of time the 7-day moving average of daily maximum simulated 1994 water temperature at Stafford Road (river mile 5.5) exceeds 17.8 degrees Celsius for each management scenario during each month.....50

CONVERSION FACTORS

Multiply	By	To obtain
acre	4,047	square meter (m ²)
acre-foot (acre-ft)	1,233	cubic meter (m ³)
cubic foot per second (ft ³ /s)	0.02832	cubic meter per second (m ³ /s)
inch	25.4	millimeter (mm)
foot (ft)	0.3048	meter (m)
mile (mi)	1.609	kilometer (km)
square mile (mi ²)	2.590	square kilometer (km ²)
cubic yard (yd ³)	0.7646	cubic meter (m ³)
Temperature in degrees Celsius (°C) as follows: °C = (°F – 32)/1.8.		

Sea level: In this report “sea level” refers to the National Geodetic Vertical Datum of 1929 (NGVD of 1929)—a geodetic datum derived from a general adjustment of the first-order level nets of both the United States and Canada, called Mean Sea Level of 1929.

Relations of Tualatin River Water Temperatures to Natural and Human-Caused Factors

By John C. Risley

Abstract

Aquatic research has long shown that the survival of cold-water fish, such as salmon and trout, decreases markedly as water temperatures increase above a critical threshold, particularly during sensitive life stages of the fish. In an effort to improve the overall health of aquatic ecosystems, the State of Oregon in 1996 adopted a maximum water-temperature standard of 17.8 degrees Celsius (68 degrees Fahrenheit), based on a 7-day moving average of daily maximum temperatures, for most water bodies in the State. Anthropogenic activities are not permitted to raise the temperature of a water body above this level. In the Tualatin River, a tributary of the Willamette River located in northwestern Oregon, water temperatures periodically surpass this threshold during the low-flow summer and fall months. An investigation by the U.S. Geological Survey quantified existing seasonal, diel, and spatial patterns of water temperatures in the main stem of the river, assessed the relation of water temperatures to natural climatic conditions and anthropogenic factors (such as wastewater-treatment-plant effluent and modification of riparian shading), and assessed the impact of various flow management practices on stream temperatures. Half-hourly temperature measurements were recorded at 13 monitoring sites from river mile (RM) 63.9 to RM 3.4 from May to November of 1994. Four synoptic water-temperature surveys also were conducted in the upstream and downstream vicinities of two wastewater-treatment-plant outfalls. Temperature and streamflow time-series data were used to calibrate two dynamic-flow heat-transfer models, DAFLOW-BLTM (RM 63.9–38.4) and CE-QUAL-W2 (RM 38.4–3.4). Simulations from the models provided a basis for approximating

“natural” historical temperature patterns, performing effluent and riparian-shading sensitivity analyses, and evaluating mitigation management scenarios under 1994 climatic conditions. Findings from the investigation included (1) under “natural” conditions the temperature of the river would exceed the State standard of 17.8 degrees Celsius at many locations during the low-flow season, (2) current operation of wastewater-treatment plants increases the temperature of the river downstream of the plants under low-flow conditions, (3) river temperature is significantly affected by riparian shade variations along both the tributaries and the main stem, (4) flow releases during the low-flow season from the Henry Hagg Lake reservoir decrease the river temperature in the upper section, and (5) removal of a low diversion dam at RM 3.4 would slightly decrease temperatures below RM 10.0.

INTRODUCTION

Water temperature is considered one of the most important factors determining the overall health of fish and other aquatic organisms. A variety of human-caused factors, such as storm-sewer runoff, effluent from wastewater-treatment plants (WWTPs), and removal of riparian vegetation can contribute to warming of water temperatures. If water temperatures warm beyond a critical threshold, particularly during the sensitive life stages of fish, fish survival can markedly decrease (Mullane and others, 1995).

Background

The Tualatin River, a tributary of the Willamette River, is located west of Portland in northwestern Oregon (fig. 1). Approximately 50 percent of the 712-square-mile drainage basin is forestland, 35 percent is used for agriculture, and 15 percent is urbanized.

Figure 1. The Tualatin River Basin, Oregon.

Partly because of its slow and meandering flow and the naturally high phosphorus content of basin soils, the river has had water-quality problems, such as excessive algal growth, low dissolved oxygen levels, fish kills, and foul odor, throughout much of this century as urban and agricultural development have expanded.

In 1996, the State of Oregon revised regulations intended to improve the condition of the river by focusing on indicator water-quality parameters, such as phosphorus, nitrate, pH, bacteria, and stream temperature. The critical water temperature thresholds

for many cold-water species in the river is surpassed during low-flow periods from June to September. Under the new regulations, for waterways like the Tualatin River, a point-source discharge is not permitted to raise the temperature of the receiving water body if the receiving water body already has exceeded 17.8°C (degrees Celsius) (64°F [degrees Fahrenheit]) on the basis of a 7-day moving average of daily maximum temperatures (Oregon Administrative Rules 340-41-006 [54], 1/11/96). In the Tualatin River, the primary point-source discharge to the river during low-flow periods is effluent from WWTPs.

From May through November, the mean temperature of the effluent is 20°C. During the months from June through September, water temperatures in the lower part of the Tualatin River (river mile [RM] 38 to RM 0) typically violate the 17.8°C criterion. The July mean of the 7-day moving average of daily maximum water temperatures commonly is over 22°C.

Remedial measures to ensure that the temperature of the effluent does not cause violations of the State water-temperature regulations could be prohibitively expensive to the public. Some of these measures include piping the WWTP effluent to multiple release points along the river or to streams outside of the basin, effluent refrigeration, flow augmentation, and effluent storage. Before effective remedial measures can be designed, a better understanding of water temperature and its relation to climatic, seasonal, diel, and human-related impacts needs to be developed and quantified, both spatially and temporally. It also is critical to compare the impact on stream temperature of riparian vegetation removal relative to the impact of WWTP effluent. For these reasons, the Unified Sewerage Agency (USA) of Washington County and the U.S. Geological Survey (USGS) began a cooperative study of Tualatin River water temperature in 1994.

Purpose and Scope

The objectives of the study were to (1) quantify the temporal and spatial patterns of water temperature in the main stem of the Tualatin River and the mouths of its major tributaries, (2) determine the relation of water temperature in the Tualatin River and its major tributaries to climatic conditions, seasonal and diel variations, and human-caused factors, and (3) assess the impact of various flow-management practices on stream temperature during the low-flow season (June through September).

The approach used to meet the study objectives included field data collection and computer modeling. Water-temperature, meteorological, and stream-discharge data were collected on a half-hourly basis at fixed-station continuous-monitoring sites located throughout the main stem and near the mouths of the major tributaries from May through November 1994. Synoptic water-temperature measurements also were collected upstream and downstream of the effluent release points of the two principal WWTPs, Rock Creek at RM 38.1 and Durham at RM 9.3 (fig. 1). The field data were used to calibrate flow and heat-

transport computer models. The calibrated models were used to simulate current and potential management scenarios in the Tualatin River from near Gaston (RM 63.9) to the low-head diversion dam near West Linn (RM 3.4) (fig. 1, sites 1 and 17).

The purpose of this report is to provide (1) a description of the data-collection program, (2) a description of the computer-simulation models used in the analyses, (3) a description of the calibration of these models, and (4) the results of computer simulations of various management scenarios. Tables of daily minimum, maximum, and mean values for all the fixed-station water-temperature and meteorological data collected during the study are provided in a separate report (Risley and Doyle, 1997). Half-hourly water-temperature data and hourly meteorological data from the fixed-station sites also are available in digital American Standard Code for Information Interchange (ASCII) format from the USGS Oregon District office. Additional information is available in a series of data and interpretive reports from another cooperative water-quality study of the Tualatin River conducted by the USA and USGS (Doyle and Caldwell, 1996; Kelly, 1996; V.J. Kelly, U.S. Geological Survey unpub. data, 1995; S.A. Rounds, U.S. Geological Survey, unpub. data, 1995).

Acknowledgments

The author gratefully acknowledges several agencies and individuals for assistance during the study. The Unified Sewerage Agency of Washington County, Oregon, provided logistical support, data, and cooperative funding; Janice Miller and Tom VanderPlaat were especially helpful. Wally Otto of the Tualatin Valley Irrigation District provided logistical support and data. Jerry Rodgers, Oregon Water Resources Department, provided stage data and discharge measurements that were used to define boundary conditions for model simulations. Carl Borg, Joint Water Commission, provided withdrawal flow data. Charles Schaefer, Lake Oswego Corporation, provided dam-configuration data. George Taylor, Oregon State Climate Service, provided meteorological data. Don Neal, Scholls, Oregon, is gratefully acknowledged for routinely providing access through his property to the Tualatin River. The U.S. Geological Survey also extends its appreciation to the numerous landowners who provided river access. Finally, a special thanks is given to Stewart A. Rounds of the U.S. Geological Survey for his support throughout the study.

DESCRIPTION OF THE STUDY AREA

Approximately one-half of the Tualatin River Basin, primarily in the western and northern upland regions, is covered with coniferous forests. Agricultural lands, located primarily in the flatter central and eastern regions, encompass about 35 percent of the basin. Primary agricultural activities in the basin include nurseries, dairies, berry crops, grains, orchards, and pastureland. About 15 percent of the basin, mostly in the eastern region, is urbanized. The population in the basin is currently over 300,000 and increasing. The major cities and towns of the basin include Beaverton, Hillsboro, Tigard, Tualatin, and Forest Grove. The study area is located in the central, mostly flat agricultural region of the basin. The river section simulated in the modeling, Gaston (RM 63.9) to the low-head diversion dam at RM 3.4, drops approximately 80 ft (feet) in elevation over its length. Most of this section is slow and meandering and generally follows a northwest to southeast direction.

Physical Setting

The Tualatin River Basin is bounded by the Coast Range on the west and northwest, the Tualatin Mountains on the east and northeast, and the Chehalem Mountains and Parrett Mountain on the south. The basin extends northwest to southeast in approximately an oval shape, about 65 miles long and 30 to 40 miles wide. The altitude of the basin ranges from nearly 3,000 ft in the Coast Range to approximately 60 ft in the southeast at the Willamette River confluence. Above the study area (from RM 79.4 to RM 55.3) in the headwater reach, the river is fairly narrow (less than 50 ft) with an average slope of 74 ft/mi (feet per mile). Between RM 55.3 and RM 33.3, the river begins to meander and has an average slope of 1.3 ft/mi and a width of about 50 ft. The flow is continuous and well mixed throughout the year. Farther downstream, the river flows into a reservoir-like reach (RM 29.7 to RM 3.4), which has an estimated slope of only 0.08 ft/mi. The low gradient is the result of the low-head diversion dam at RM 3.4. In this reach, the river widens to roughly 150 ft and thereby exposes much of the river surface to direct solar insolation. Below RM 3.4 to the mouth, the river is characterized by small pools and riffles and has an average slope of 1.3 ft/mi. Major tributaries to the Tualatin River include Scoggins Creek (RM 60.0),

Gales Creek (RM 56.7), Dairy Creek (RM 44.8), Rock Creek (RM 38.1), and Fanno Creek (RM 9.3).

Riparian vegetation along the study reach is dominated by white oak, ash, and cottonwood, with an understory of grass and shrubs. The few stream sections within the study area which are bordered by coniferous trees, mostly Douglas firs, are located in the lower section of the river from RM 10.0 to RM 0.0.

Most soils in the study area can be characterized as silt loams and loams that are moderately well drained and contain naturally high concentrations of phosphorus. Geologic formations of the basin are mostly of volcanic and sedimentary origin and contain rock units formed during the Eocene and Oligocene ages of the Tertiary period. The volcanic rocks consist mainly of basaltic lavas and tuffs. They are overlain by sedimentary rocks and unconsolidated materials—mostly shale, claystone, sandstone, and siltstone (Hart and Newcomb, 1965).

Climate

The study area climate is characterized as modified maritime with annual precipitation averaging about 45 inches per year. Most of the precipitation occurs as rainfall during the winter from November through April, when a nearly continuous series of low-pressure storm systems move eastward from the Pacific Ocean. Summer months (May to October) are generally dry, with typically less than 1 inch of rain falling during July and August. The maritime influence on the basin climate maintains generally mild temperatures throughout the year. Mean minimum and maximum air temperatures are 0 and 17°C during the winter and 5 and 28°C during the summer. Cloudy skies predominate during the winter, but summers tend to be clear and sunny. Although intermittent periods of cloud cover occur, sunlight intensity peaks during May through July and gradually decreases as the summer progresses.

Hydrology

Streamflow in the Tualatin River is generally associated with the seasonal precipitation pattern. Flows are usually high from December through March and low from July through October. The monthly distribution of daily mean streamflows in the river at West Linn (RM 1.8) is shown in figure 2.

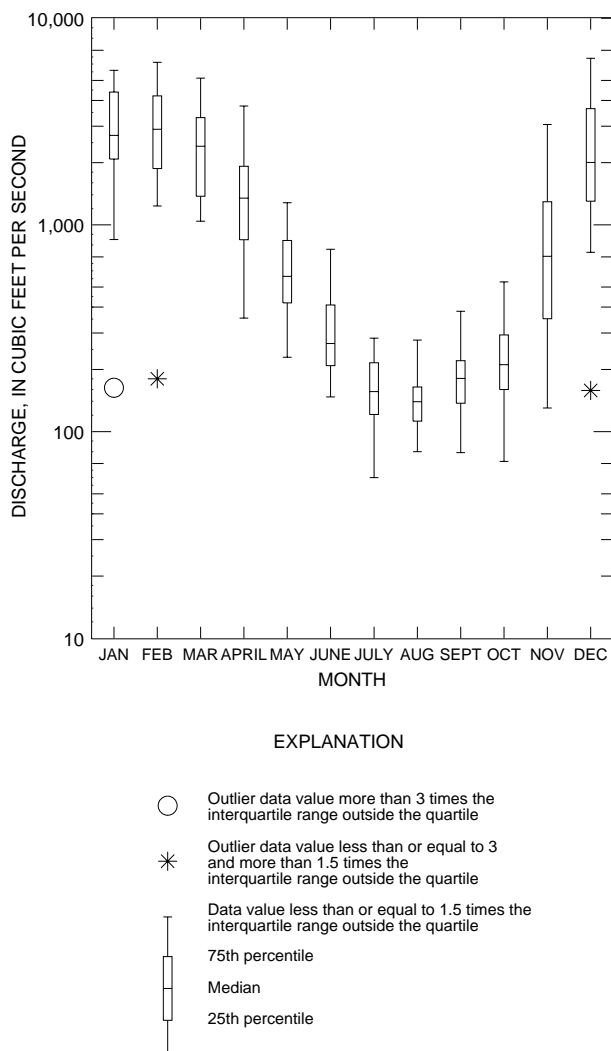

Figure 2. Monthly distribution of daily mean streamflows in the Tualatin River at West Linn, Oregon (14207500), 1975–94.

Prior to 1975, summer and fall flows in the river periodically dropped below $10 \text{ ft}^3/\text{s}$ (cubic feet per second). From 1955 to 1974, the mean flow for August at West Linn was $16.8 \text{ ft}^3/\text{s}$. These low flows were largely attributable to limited natural baseflow and extensive water withdrawals for irrigation and municipal water supply. After construction of Scoggins Dam in 1975, which created Henry Hagg Lake reservoir (fig. 1), summer and fall flows have been augmented to maintain a level of approximately $100\text{--}200 \text{ ft}^3/\text{s}$ at Farmington (RM 33.3). From 1975 to 1994, the mean flow for August at West Linn was $142.4 \text{ ft}^3/\text{s}$.

Time-of-travel estimates for flow in the mainstem of the river have been made on the basis of dye studies conducted by USA in the mid-1980s

(Janice Miller, Unified Sewerage Agency of Washington County, Oregon, written commun., 1995) and the USGS in 1992 (Lee, 1995). During typical summer low-flow conditions (between 100 and $300 \text{ ft}^3/\text{s}$), travel times from RM 58.8 to the mouth range from 10 to 24 days. The travel time is highest in the lower river, between RM 26.9 and the low-head diversion dam at RM 3.4.

Flow Management

As agriculture and urban development grew during this century, the Tualatin River came under increasing flow regulation. In addition to Scoggins Dam, flows in the headwaters of the Tualatin River are augmented by a diversion from the Trask River Basin, which is located on the western side of the Coast Range Mountains. Flows are generally augmented during the summer by the Joint Water Supply Commission, which supplies municipal water to several cities in the basin. Withdrawals for municipal water supplies are made at the Spring Hill Pumping Plant located on Fern Hill Road at RM 56.1. Additional withdrawals from the river are made from this plant for irrigation supply by the Tualatin Valley Irrigation District (TVID). Depending on irrigation needs during the summer, between 25 and $125 \text{ ft}^3/\text{s}$ is typically withdrawn. Additional irrigation withdrawals are taken directly from the river by users at numerous locations along the main stem.

Flows from the other major tributaries, downstream of Scoggins Creek, are unregulated. Major tributaries are shown in figure 3. Flows from Rock Creek and Dairy Creek are predominately from farmland drainage. Much of Fanno Creek flow is from urban drainage. During May to December 1994, the two principal USA WWTPs, Rock Creek (RM 38.1) and Durham (RM 9.3), each discharged an average of approximately $30 \text{ ft}^3/\text{s}$ (19 million gallons per day) of treated effluent into the river. During the summer, treated secondary effluent from two other smaller WWTPs (near Hillsboro and Forest Grove) is used for irrigation and is not discharged directly to the river. At RM 6.7, a gravity flow canal (Oswego Canal) diverts approximately $60 \text{ ft}^3/\text{s}$ of water from the Tualatin River to Lake Oswego. The flow is used to operate a small hydropower plant owned by the Lake Oswego Corporation. The flow through the canal is enabled by the low-head diversion dam on the Tualatin River near West Linn at RM 3.4.

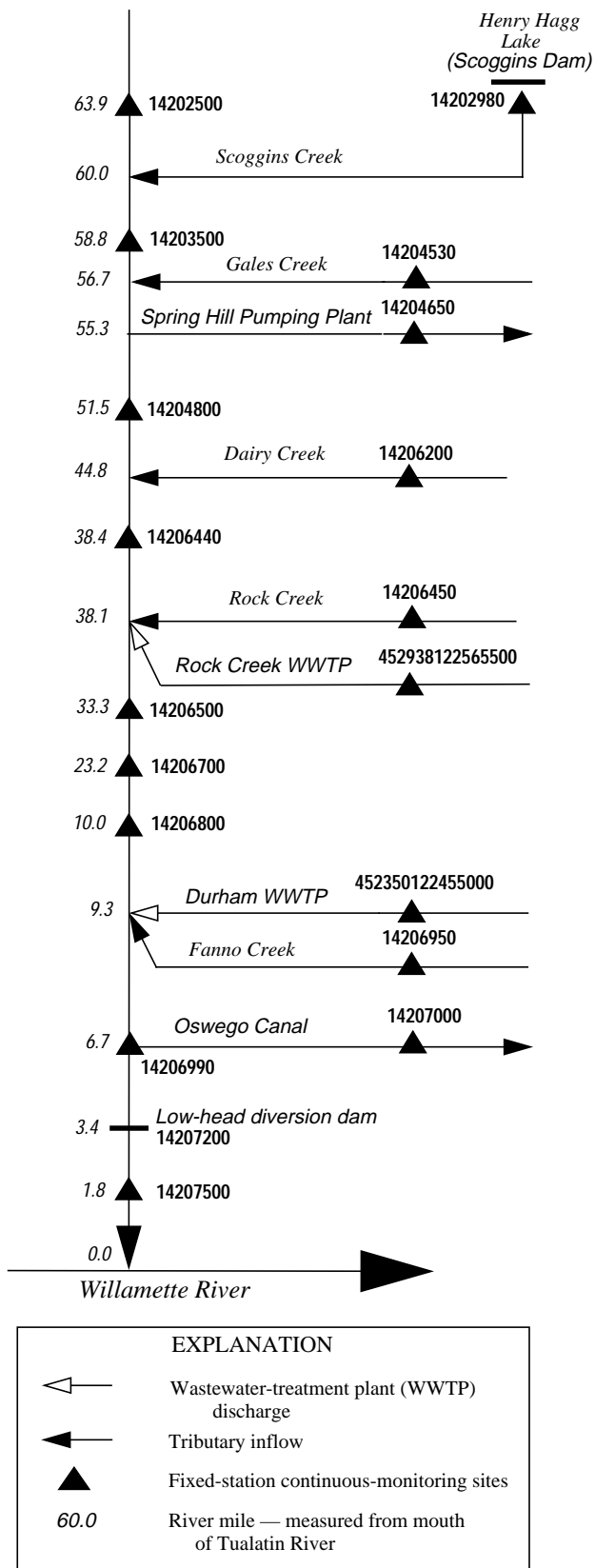

Figure 3. Relative positions of selected tributaries, fixed-station continuous-monitoring sites, and wastewater-treatment plants, Tualatin River Basin, Oregon, 1994.

Reservoir release schedules and water withdrawals are coordinated by the Tualatin River Flow Management Technical Committee. The committee is made up of representatives from various State and local water agencies and convenes monthly throughout the year.

DATA COLLECTION

Continuous water-temperature, streamflow, and meteorological data were collected from May 1, to November 30, 1994, at fixed-station continuous-monitoring sites established by the USGS, Oregon Water Resources Department (OWRD), and other agencies. Additional data collected for the study included measurements from synoptic water-temperature surveys near the Rock Creek and Durham WWTPs, channel cross-section measurements, and riparian shading surveys. Additional data also were collected at the fixed-station continuous-monitoring sites from May 1 to November 30, 1995. However, only data from the 1994 period were used in the modeling simulations presented in this report.

Fixed-Station Continuous-Monitoring Sites

Data from the fixed-station continuous-monitoring sites were collected and recorded on either an instantaneous basis or a time-interval-averaged hourly or half-hourly basis. These sites are listed in table 1 and their relative locations are shown in figure 3.

Water Temperature

Continuous water-temperature measurements were recorded by the USGS at 13 stream locations on the main stem of the Tualatin River (between RM 63.9 and RM 3.4) and on major tributaries near their mouths. Instantaneous data were measured at these locations at 30-minute intervals from May 1 through November 30, 1994. Minimum, maximum, and daily mean values for all the fixed-station data have been reported by Risley and Doyle (1997). That report also contains a description of the data-collection equipment used, the data-collection protocols, and the quality-assurance protocols.

Cross-section surveys were conducted at all of the water-temperature fixed stations to confirm that the temperature probe was positioned in a representative location within the stream. Two water-temperature cross-section surveys were conducted during the low-flow periods of May 25–26, 1994, and also on September 7, 1994.

Table 1. List of U.S. Geological Survey fixed-station continuous-monitoring sites in the Tualatin River Basin, Oregon, 1994 [D, discharge; WT, water temperature; AT, air temperature; WS, wind speed; SR, solar radiation; X, data collected; ---, data not collected]

Site number	Station name	Station number	Station location		River mile	collected Data			WS	SR
			Latitude	Longitude		D	WT	AT		
1	Tualatin River near Gaston	14202500	45°26'15"	123°10'05"	63.9	X	X	---	---	---
2	Scoggins Creek below Henry Hagg Lake, near Gaston	14202980	45°28'10"	123°11'56"	4.3	X	X	---	X	X
3	Tualatin River near Dilley	14203500	45°28'30"	123°07'23"	58.8	X	X	---	---	---
4	Gales Creek at Route 47 at Forest Grove	14204530	45°30'39"	123°06'52"	1.5	X	X	---	---	---
5	Tualatin River at Golf Course Road near Cornelius	14204800	45°30'08"	123°03'18"	51.5	X	X	X	---	---
6	Dairy Creek at Route 8 near Hillsboro	14206200	45°31'12"	123°00'34"	2.1	X	X	---	---	---
7	Tualatin River at Rood Bridge at Hillsboro	14206440	45°29'25"	122°57'01"	38.4	X	X	---	---	---
8	Rock Creek near Hillsboro	14206450	45°30'09"	122°56'48"	1.2	X	X	X	---	---
9	Rock Creek Wastewater-Treatment Plant near Hillsboro	45293812-2565500	45°29'38"	122°56'55"	38.1	---	---	---	X	X
10	Tualatin River at Farmington	14206500	45°27'00"	122°57'00"	33.3	X	X	---	---	---
11	Tualatin River near Scholls	14206700	45°23'39"	122°53'51"	23.2	---	X	---	---	---
12	Tualatin River near Tualatin	14206800	45°23'28"	122°46'22"	10.0	---	X	---	---	---
13	Durham Wastewater-Treatment Plant near Durham	45235012-2455000	45°23'50"	122°45'50"	9.3	---	---	X	X	X
14	Fanno Creek at Durham	14206950	45°24'13"	122°45'13"	1.1	X	X	---	---	---
15	Tualatin River at Oswego Canal at Tualatin	14206990	45°22'57"	122°43'12"	6.7	X ¹	---	---	---	---
16	Oswego Canal near Lake Oswego	14207000	45°23'20"	122°43'10"	.4	X	---	---	---	---
17	Tualatin River at dam near West Linn	14207200	45°21'24"	122°41'02"	3.4	---	X	X	---	---
18	Tualatin River at West Linn	14207500	45°21'03"	122°40'30"	1.8	X	---	---	---	---

¹ Stage-recording station only.

Data from these surveys are presented by Risley and Doyle (1997). With the exception of RM 10.0 and at the low-head diversion dam site (RM 3.4), the streams were both laterally and vertically well mixed at these sites (variation within 0.5°C). The greatest temperature variation at the RM 10.0 and RM 3.4 sites was less than 1.5°C.

The USA measured and recorded instantaneous effluent temperature data at both WWTPs on a half-hourly basis. The laboratories of the two main WWTPs also measured effluent temperature every day at approximately 9:00 a.m. Temperature probes used by the USA at both WWTPs were checked with a certified temperature probe during the summer of 1994. Correction shifts were applied to the USA data before they were used in the modeling.

Streamflow

Streamflow data were collected by the USGS, OWRD, and USA at various locations in the Tualatin River Basin, but not specifically for this study. Flow data collected at 11 stream-gaging stations were used as boundaries in the modeling simulations of this study. These data were collected by USGS and OWRD according to standardized techniques of the USGS (Rantz and others, 1982). The stations are listed in table 1. The USGS-operated gaging stations included Scoggins Creek below Henry Hagg Lake near Gaston (14202980), Tualatin River near Dilley (14203500), and Fanno Creek at Durham (14206950). The USGS also operates a gaging station on the Tualatin River at West Linn (14207500); however, data from this station were not used as a boundary in the modeling. The remaining eight stations used in the modeling were operated by OWRD. However, flow record computations for all the stations were made by USGS personnel using field measurement notes, stage recorder paper tapes, and digital files supplied by OWRD. In addition to the 11 streamflow-gaging stations, stage data were recorded by OWRD on the Tualatin River at the Oswego Canal (14206990). Although flow computations were not made for this station, the stage data were used in determining the approximate water levels during the modeling calibration simulations.

Hourly effluent flow measurements from both the Rock Creek and Durham WWTPs were made and recorded by the USA. These data were used as boundary conditions for the modeling simulations.

Data on the daily mean rate of water withdrawal from the river at the Spring Hill Pumping Plant (RM 56.1) also were necessary for the modeling. Water withdrawn for irrigation was measured and recorded by the TVID. The TVID equipment was checked and calibrated by the USGS in December 1991 and March 1993. Water withdrawn at the same location for urban water supply was measured and recorded by the Joint Water Commission.

Meteorological

Air-temperature, wind-speed, and solar-radiation data were collected at three locations as a part of this study (table 1). Additional fixed-station meteorological data also were used, including hourly dewpoint-temperature and hourly wind-direction data collected by personnel of the Hillsboro Airport.

Synoptic Water-Temperature Surveys

The synoptic water-temperature surveys provided an understanding and allowed quantification of the effects of WWTP effluent on the main-stem water temperature. Four surveys were conducted upstream and downstream of the effluent outlets of both the Rock Creek and Durham WWTPs. Most of the effluent released into the Tualatin River by the USA came from these two WWTPs. The surveys were conducted during the late summer and early fall, because the impact of the effluent is greatest during these periods. During each survey, river flows were less than 200 ft³/s and the water temperature was approaching or had surpassed a temperature threshold of 17.8°C, which is considered detrimental to the survival of certain fish species. For each survey, six temperature probes were positioned within a 1-mile section of the river upstream and downstream of the outlet. Because of diel variations in water temperature, it was necessary to conduct each survey over a minimum of a 48-hour period. The data collected from the surveys are presented by Risley and Doyle (1997).

Channel Cross-Section Measurements

Bathymetric data of the main stem of the Tualatin River were collected and compiled in previous studies (V.J. Kelly, U.S. Geological Survey, unpub. data, 1995; S.A. Rounds, U.S. Geological Survey, unpub. data, 1995; Laenen and Risley, 1997).

Fifty-two cross sections were measured by the USGS in 1990, and an additional 31 cross sections were measured by the USA in 1986 in the lower section of the river (RM 38.4 to RM 3.4). The USGS also measured a continuous mid-channel profile by recording depths from a Lowrance sonar device while traveling the river thalweg from RM 3.4 to RM 36.6 in 1990. Additional bathymetric information was obtained from the U.S. Army Corps of Engineers (1953). However, that information was used only to verify the more recently collected data. For this study, 15 new bed-profile cross sections, spaced approximately 1 to 2 miles apart, were measured in the upper section of the river between Rood Bridge (RM 38.4) and Gaston (RM 63.9) during low-flow conditions in October 1994.

Riparian Shading Measurements

Riparian shading data were compiled from field cross-section surveys, aerial photography, and topographic maps. Because of the high level of variability in riparian shading along stream reaches, established field techniques (Bartholow, 1989) were used to optimize data collection, assuring that sufficient data were collected without making the survey too costly.

The most significant obstruction of solar radiation on the water surface of the Tualatin River is vegetation. Because of the flatness of the Tualatin Valley, it was assumed that topographic blockage of radiation in the study area was limited to the height of the streambank.

The shade parameters that were measured in the field included V_h , average vegetation height; V_c , crown measurement (average tree width); V_o , average vegetation offset; V_d , vegetation density; W , stream width; and B_h , bank height (fig. 4). These parameters were estimated at 30 locations in the study reach between Gaston (RM 63.9) and the low-head diversion dam at RM 3.4. Field equipment included a handheld inclinometer, a distance range finder, a light meter, and measuring tapes.

The height of vegetation (V_h) is the average maximum height of the overstory riparian vegetation above the water surface. Crown measurement (V_c) is the average of the maximum diameter of the riparian vegetation immediately adjacent to the stream. Vegetation offset (V_o) is the average distance between the edge of the water and the tree trunks. V_o and V_c are used in the shading model to compute the net vegetation overhang. Vegetation density (V_d) is a

measure of solar light actually blocked by the riparian vegetation. V_d accounts for both the continuity of riparian vegetation along the streambank and the filtering effect of leaves. For example, if only 50 percent of one side of the stream has riparian vegetation, which screens out only 50 percent of the sunlight, then V_d for that side of the stream is 0.25.

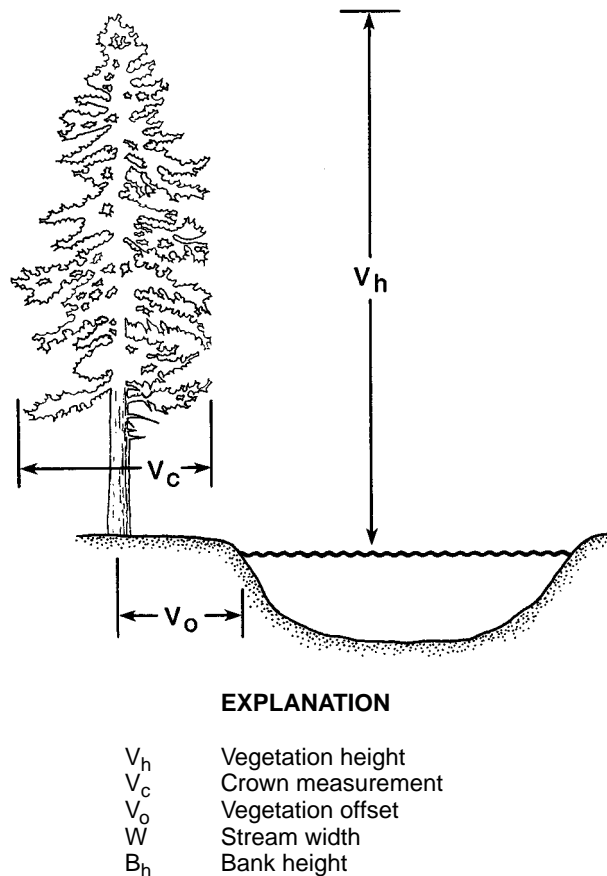

Figure 4. Riparian vegetation shade parameters.

To estimate riparian shading for stream reaches between the 30 field-measurement cross-section sites, the entire study reach was discretized into segments that were approximately one-quarter to one-half mile in length. The azimuth of each segment, measured from USGS topographic maps, was an additional parameter necessary for estimating total riparian shading (fig. 5). The azimuth is a measure of the average departure angle of the stream segment from a north-south reference. For example, for streams oriented from north-south, the azimuth is 0 degrees; for streams oriented northwest-southeast, the azimuth is less than 0 degrees; and, for streams oriented northeast-southwest, the azimuth is greater than 0 degrees. All stream-reach azimuth angles are between -90 and 90 degrees.

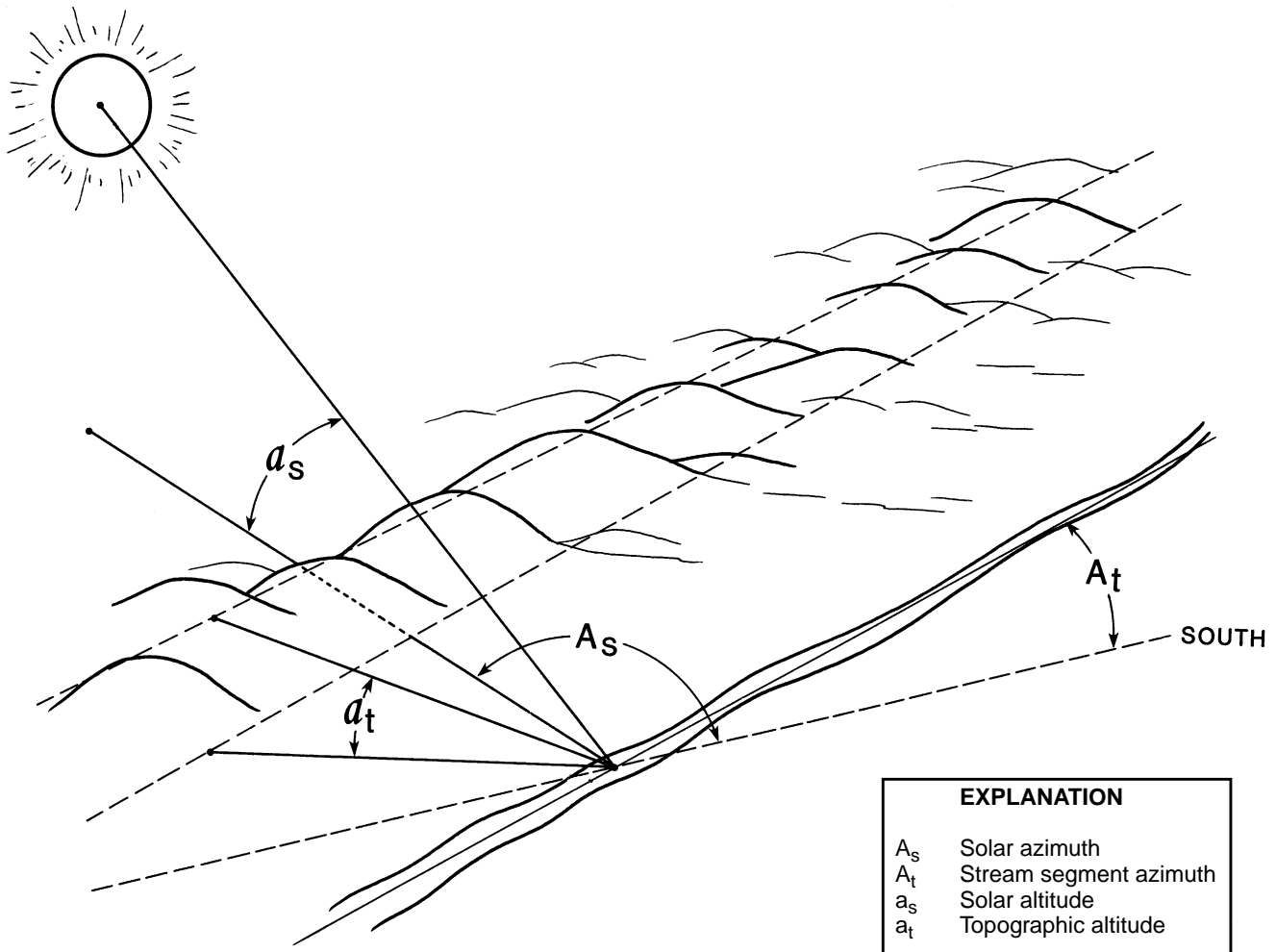

Figure 5. Local solar and stream orientation angle measurements.

Aerial photography was used to determine the approximate canopy thickness and vegetation density of both banks of each stream segment. The canopy thickness of each segment was categorized as (1) no vegetation, (2) single row vegetation with approximately 50 percent crown closure, (3) single row vegetation with approximately 100 percent crown closure, (4) thick double row vegetation, and (5) completely wooded areas. The segments also were classified as predominately deciduous or coniferous. Although most of the vegetation along the Tualatin River is deciduous, some coniferous vegetation was identified in aerial photographs.

Segments that were nearly devoid of any vegetation were assigned a minimum and maximum vegetation density of 0 and 5 percent, respectively. Those with single row vegetation with 50 percent crown closure were assigned a minimum and maximum vegetation density of 25 and 30 percent, respectively. Those with single row vegetation with 100 percent

crown closure were assigned a minimum and maximum vegetation density of 50 and 55 percent, respectively. Those with thick double-row vegetation were assigned a minimum and maximum vegetation density of 70 and 75 percent, respectively. Those with completely wooded areas were assigned a minimum and maximum vegetation density of 80 and 85 percent, respectively. The vegetation densities and the values of the other shade parameters described above are listed in Appendix A.

DESCRIPTION OF THE COMPUTER MODELS

Three computer models were used to estimate riparian shading coefficients for the full study reach (RM 63.9 to RM 3.4), to simulate flow and heat transport in the upper stream section (RM 63.9 to RM 38.4), and to simulate flow and heat transport in the lower stream section (RM 38.4 to RM 3.4).

Riparian shading coefficients estimated by the first model were used as input data for the flow and heat-transport models used in both the upper and lower stream sections. The full study reach (RM 63.9 to RM 3.4) was divided into an upper and a lower stream section, because flow conditions in each section warranted using different models. Streamflow in the upper stream section above Rood Bridge (RM 38.4) is well mixed throughout the year. However, the stream at pool locations below Scholls Ferry Bridge (RM 26.9) becomes thermally stratified during low-flow periods. A one-dimensional flow and heat-transport model was selected for the upper stream section and a two-dimensional laterally averaged flow and heat model was selected for the lower stream section.

Computation of Shading Coefficients

The Stream Network Temperature Model (SNTEMP) was developed by (Theurer and others, 1984). The shade subroutine of the model was used in this study to estimate solar-radiation-weighted riparian shading resulting from both topography and vegetation. Monthly mean shading coefficients (from May through November) were estimated for approximately 270 stream segments between Gaston (RM 63.9) and the low-head diversion dam at (RM 3.4).

Algorithms

A complete description of the algorithms used in the SNTEMP shading subroutine is provided by Theurer and others (1984). This model calculated total riparian shading coefficients, which are the sum of topographic and vegetation shade on both sides of the stream.

$$S_h = S_t + S_v, \quad (1)$$

where

- S_h is total shade,
- S_t is topographic shade, and
- S_v is vegetation shade.

Variations in topography and vegetation on each side of the stream are taken into account in the model's computations. Although the algorithms took into account variations in solar radiation for each calendar day, the model output was lumped into monthly mean values. These monthly mean shading coefficients, representing existing conditions for both upper and lower stream sections, are presented in Appendix B.

However, during the calibration of the heat-transport models, these coefficients were adjusted. The adjusted shade coefficients were used in the modeling scenario simulations.

Data Requirements

Required input data from each stream segment for the SNTEMP shade subroutine include (1) Julian date, (2) site latitude, (3) stream segment azimuth, A_t , (4) topographic altitude, a_t (both sides), (5) vegetation height, V_h (both sides), (6) crown measurement, V_c (both sides), (7) vegetation offset, V_o (both sides), (8) vegetation density, V_d (both sides), and (9) stream width, W . Some of these components are illustrated in figures 4 and 5.

The topographic altitude (a_t) is the vertical angle from a level line at the streambank to the approximate top of the local terrain. The altitude angle would be zero for level plane topography and greater than zero for hilly or canyon terrain. In the Tualatin River, the topographic altitude was usually a function of only the streambank height (B_h) and width of the stream (W).

Upper Stream Section Modeling

The Diffusion Analogy Flow model (DAFLOW) and Branched Lagrangian Transport Model (BLTM), used for the Rood Bridge (RM 38.4) to Gaston (RM 63.9) stream section, are flow and transport models, respectively, developed and maintained by the Office of Surface Water of the USGS. The two models are typically used conjunctively. The simulated output from DAFLOW (consisting of flow, cross-section area, width, and tributary flows) is used as input to BLTM. The models have been used in various surface-water and water-quality studies (Jobson and Keefer, 1979; Jobson, 1981; Jobson, 1989).

Algorithms

DAFLOW is an unsteady-state (dynamic), one-dimensional (longitudinal), streamflow-routing model based on a simplified version of the momentum equation. DAFLOW uses a Lagrangian solution scheme; such a scheme uses a computational x-coordinate reference frame that moves with the flow rather than remaining at a fixed grid location. Further details of the numerical methods have been described by Jobson (1989).

BLTM is a one-dimensional transport (water-quality) model capable of simulating the transport of solutes and heat in branched river systems. BLTM solves the convective-dispersion equation using a Lagrangian reference frame in which the computational nodes move with the flow. Unsteady-state hydraulics (flow, width, and cross-sectional area) are required input for BLTM. Solute concentrations and heat are assumed to have no effect on the hydraulics.

In the Lagrangian reference frame, the continuity of mass equation, as used in this study, is:

$$\frac{\partial T}{\partial t} = \frac{\partial}{\partial \zeta} \left[D \frac{\partial T}{\partial \zeta} \right] + \Phi + H_n, \quad (2)$$

where

T is water temperature,

t is time,

D is the longitudinal dispersion coefficient,

Φ is the rate of change in temperature due to tributary inflow,

H_n is net heat transfer, and

ζ is the Lagrangian distance coordinate, given by

$$\zeta = x - x_o - \int_{t_o}^t u dt, \quad (3)$$

where

x is the Eulerian (stationary) distance coordinate along the river,

u is the cross-sectional mean stream velocity, and

x_o is the location of the parcel at time t_o .

One-dimensional transport theory is explained in more detail in the BLTM user's manual (Jobson and Schoellhamer, 1987).

The net heat-transfer rate in BLTM is defined as:

$$H_n = -K(T - T_e), \quad (4)$$

where

H_n is the net heat-transfer rate through the water surface,

K is the heat-exchange coefficient,

T is the water temperature, and

T_e is the equilibrium temperature.

The equilibrium temperature is the temperature that the water body is tending towards, given the instantaneous sum of heat sources and sinks. On the basis of this equilibrium approach, the water body is gaining

heat when T is less than T_e and losing heat when T is greater than T_e . No heat exchange occurs when T is equal to T_e .

The mathematical algorithms used to compute the heat-exchange coefficient (K) and equilibrium temperature (T_e) are presented in Appendix C. Time-varying incoming shortwave-solar-radiation, wind speed, air temperature, and dewpoint-temperature data were used to compute the heat-exchange coefficient and equilibrium temperatures at each stream segment for every time step. To account for variations in riparian shading along the stream, the incoming shortwave solar radiation for a given stream segment was reduced by the riparian shading coefficient estimated by the SNTTEMP model for that stream segment by using the following equation:

$$S = S_m \times (1 - RS), \quad (5)$$

where

S is incoming shortwave solar radiation reduced for riparian shading,

S_m is measured incoming shortwave solar radiation, and

RS is the monthly riparian shading coefficient.

Data Requirements

Operation of the DAFLOW and BLTM models used in this study requires inputs of channel characteristics, initial conditions, and time-varying boundary conditions for flow and water temperature.

Channel characteristics defined for each segment include the length of the segment (miles), an initial discharge, hydraulic geometry coefficients used to compute cross-sectional area as a function of discharge, a wave dispersion coefficient, and hydraulic geometry coefficients used to compute stream-surface width as a function of discharge. Withdrawals or diversions are included as negative flow boundary conditions.

The transport model, BLTM, requires the simulated flow, cross-section area, stream-surface width, and tributary flow for every stream segment for every time step. A longitudinal dispersion coefficient is required for each branch in the system. For each stream segment, initial water temperatures must be provided. In addition, the time-varying water-temperature data for any upstream flow boundary condition is required as input to BLTM.

Time-varying meteorological data, including incoming shortwave solar radiation (langleys per day), wind speed (meters per second), air temperature (degrees Celsius), and dewpoint temperature (degrees Celsius) are required to compute the equilibrium temperature and the heat-exchange coefficient for each water parcel.

Lower Stream Section Modeling

CE-QUAL-W2 is a two-dimensional, laterally averaged, hydrodynamic water-quality model used for the Rood Bridge (RM 38.4) to low-head diversion dam (RM 3.4) reach, developed and maintained by the Waterways Experiment Station of the U.S. Army Corps of Engineers in Vicksburg, Mississippi. The hydrodynamic portion of the model was taken from a model named Generalized Longitudinal-Vertical Hydrodynamics and Transport Model (GLVHT), which in turn was based on a model named Laterally Averaged Reservoir Model (LARM) (Edinger and Buchak, 1975). CE-QUAL-W2 was created in 1975 and has been updated frequently to incorporate new algorithms and improve its accuracy. The version of CE-QUAL-W2 used in this study is a modification of CE-QUAL-W2 version 2.0 (Cole and Buchak, 1995). Most of the modifications of this version were made for an earlier USGS water-quality modeling study on the Tualatin River and are documented by S.A. Rounds, U.S. Geological Survey, unpub. data, 1995. Some additional minor coding modifications were made for this study (Appendix D).

Algorithms

CE-QUAL-W2 is a dynamic model capable of simulating water flow, heat flow, and water quality. The two dimensions simulated are longitudinal (along the length of the water body) and vertical. The model is well suited for narrow lakes and reservoirs that have minimal variation from side to side but tend to stratify.

Both hydrodynamics and water quality are simulated within a single model code. CE-QUAL-W2 uses the laterally averaged equations of fluid motion derived from three-dimensional governing equations, which include (1) horizontal momentum, (2) constituent transport, (3) free water-surface elevation, (4) hydrostatic pressure, (5) continuity, and (6) the relationships among pressure, temperature, and volume of water (Edinger and Buchak, 1975; Cole and Buchak, 1995). The solution of these six equations forms the basis of the model. Because of the complex-

ity of the governing equations, it is necessary to use advanced numerical-solution techniques. The model uses a variable time-step algorithm that is designed to ensure the mathematical stability of the numerical methods. Further details about the equations and their solution techniques are described in the user's manual (Cole and Buchak, 1995).

The main stem of the river or reservoir being modeled is defined as a branch. Numerous tributary branches can be linked to the main-stem branch. CE-QUAL-W2 represents channel bathymetry with a two-dimensional grid of cells. The two dimensions are vertical and longitudinal along the direction of flow. Lateral variations across the channel cross section are assumed to be unimportant. Vertically, the channel configuration is represented as a stack of layers (fig. 6). Each layer must have a constant elevation and thickness throughout the entire length of the channel. However, all layers are not required to have the same thickness. In the longitudinal dimension, the stack of layers is divided into segments, which are not required to have the same length.

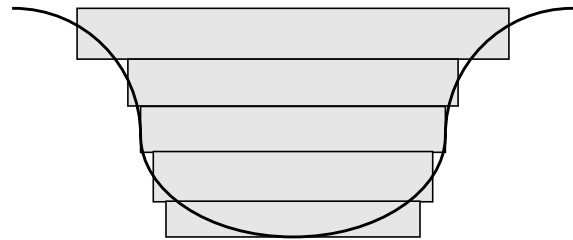

Figure 6. Model representation of a river cross section using stacked rectangles.

The CE-QUAL-W2 heat budget computes the net heat flux at the air/water interface. The model provides the user with the option of using either the direct term-by-term energy equation or the equilibrium-temperature approach. The term-by-term method was used for this study.

$$H_n = H_s + H_a + H_e + H_c - (H_{sr} + H_{ar} + H_{br}), \quad (6)$$

where

H_n is net rate of heat exchange through the water surface,

H_s is incoming shortwave solar radiation,

H_a is incoming long-wave (atmospheric) solar radiation,

H_{sr} is reflected shortwave solar radiation,

H_{ar} is reflected long-wave solar radiation,

H_{br} is long-wave back radiation of the water surface,

H_e is evaporative heat loss, and

H_c is air/water surface heat conduction.

All the terms are in units of watts per meter squared (W/m^2).

To account for variations in riparian shading along the stream, the incoming shortwave solar radiation for a given stream segment was reduced by the riparian shading coefficient estimated by the SNTMP model as presented earlier in equation 5.

In the version of the model used in this study, net shortwave solar radiation is computed as:

$$H_{sn} = H_s - H_{sr} = (1 - (1.18 \times ELEV^{0.77})) \times H_s, \quad (7)$$

where

H_{sn} is net shortwave solar radiation, and
 $ELEV$ is elevation of the sun in degrees
(Jobson and Keefer, 1979).

Net long-wave (atmospheric) solar radiation is computed as:

$$H_{an} = H_a - H_{ar} = (9.37 \times 10^{-6}) \times SB \times (273.2 + T_a)^6 \times (1 + 0.17C_l^2) \times (1.0 - 0.03), \quad (8)$$

where

H_{an} is net long-wave solar radiation,
the term (9.37×10^{-6}) is in units of $1/\text{K}^2$
(degrees kelvin [squared]),
 T_a is air temperature ($^{\circ}\text{C}$),
 SB is the Stefan-Boltzmann constant
(5.6697×10^{-8} in $\text{W}/\text{m}^2 \times \text{K}^4$), and
 C_l is cloud cover (decimal fraction).

Long-wave back radiation from the water surface is computed as:

$$H_{br} = E_w \times SB \times (T_{ws} + 273.2)^4, \quad (9)$$

where

E_w is the emissivity of water (0.97), and
 T_{ws} is the water-surface temperature ($^{\circ}\text{C}$).

Evaporative heat loss is computed as:

$$H_e = f(W) (e_s - e_a), \quad (10)$$

where

$f(W)$ is the evaporative wind-speed function
($\text{W}/\text{m}^2 \times \text{mm Hg}$ [millimeters mercury]),
 e_s is the saturation vapor pressure of the water at
the surface (mm Hg), and
 e_a is the actual atmospheric vapor pressure of the
water (mm Hg).

Surface heat conduction is computed as:

$$H_c = C_c f(W) (T_{ws} - T_a), \quad (11)$$

where

C_c is Bowen's coefficient (0.47 mm Hg/ $^{\circ}\text{C}$).

The movement of heat and solar insolation is transferred from the top layer to subsequent lower layers, as dictated by light extinction and advective and dispersive mixing. The water and heat budgets of CE-QUAL-W2 are just two of the components of the overall model. The model contains numerous algorithms that can be used to simulate a variety of complex water-quality constituent processes. Details of these processes are provided in greater detail by Cole and Buchak (1995) and S.A. Rounds (U.S. Geological Survey, unpub. data, 1996). Some code modifications made for this study to the heat sub-routine algorithms are discussed in Appendix D.

Data Requirements

Detailed bathymetric data are required to accurately define the numerical grid of the river system being modeled—the number of stream segments and the number of layers in each segment. Additional fixed data required for the model includes segment azimuth, segment shading coefficients, channel roughness coefficients, extinction coefficients, and dispersion coefficients.

Time-varying data required for the model includes meteorological, flow, and water-temperature data. The meteorological data include shortwave solar radiation, wind speed, wind direction, air temperature, and dewpoint temperature. Some of the time-varying flow and temperature data are assigned as boundary conditions for the main branch and each of the tributaries. For ground-water inflows, time-varying nonpoint flow also can enter the system as an evenly distributed “tributary.” Flow is simply added to the river along its entire length rather than just at a point. Similarly, precipitation can be evenly added to the system over the entire water-surface area. Time-varying water-temperature data can be assigned to both nonpoint ground-water inflows and precipitation. Water can be lost from the system as time-varying withdrawals or diversions, or as flow leaving the downstream end of the system. The quantity of water leaving the system from a dam structure can be calculated as a function of the water-surface elevation and the physical configuration of the dam. The quantity of water leaving the system through evaporation is computed in the heat budget.

MODEL DEVELOPMENT & CALIBRATION

To develop and calibrate flow and transport models capable of simulating water temperature conditions in the Tualatin River, it was necessary to properly configure the river system, to determine parameter values of the model and to assemble necessary input files from measured field data.

Upper Stream Section Modeling

The upper stream section extended from RM 63.9 near Gaston to Rood Bridge at RM 38.4. Because output from DAFLOW was used as input to BLTM, it was necessary to first successfully calibrate the DAFLOW model before calibrating the BLTM model.

Flow

The 116 stream segments defined for the main stem between Rood Bridge and Gaston, as well as the three main tributaries (Scoggins Creek, Gales Creek, and Dairy Creek), were the same segments defined for riparian shade parameters. The length of each segment was typically less than one-half mile, because it was necessary to assign representative vegetation density and stream azimuth values for each segment.

For the entire stream network, a total of 9 branches and 10 junctions (for assigning boundary conditions or connections) were defined (fig. 7). The three main tributaries were each defined as a branch. On the main stem, six branches were defined between Rood Bridge and Gaston. For model stability purposes, the total number of stream segments per branch was kept below 20.

Initial discharges and channel hydraulic parameters were defined for each stream segment. Many of these parameters had already been determined by Laenen and Risley (1997). In that study, a DAFLOW model was constructed for the Tualatin River between Dilley (RM 58.8) and the low-head diversion dam at RM 3.4. Channel width and elevation data were collected in the field and taken from 7.5-minute USGS quadrangle maps. Wave dispersion coefficients were estimated using time-of-travel data and the calibration guidelines suggested in the DAFLOW manual (Jobson, 1989). The time-of-travel data were collected by the USA (Janice Miller, Unified Sewerage Agency of Washington County, Oregon, written commun., 1995) and the USGS (Lee, 1995).

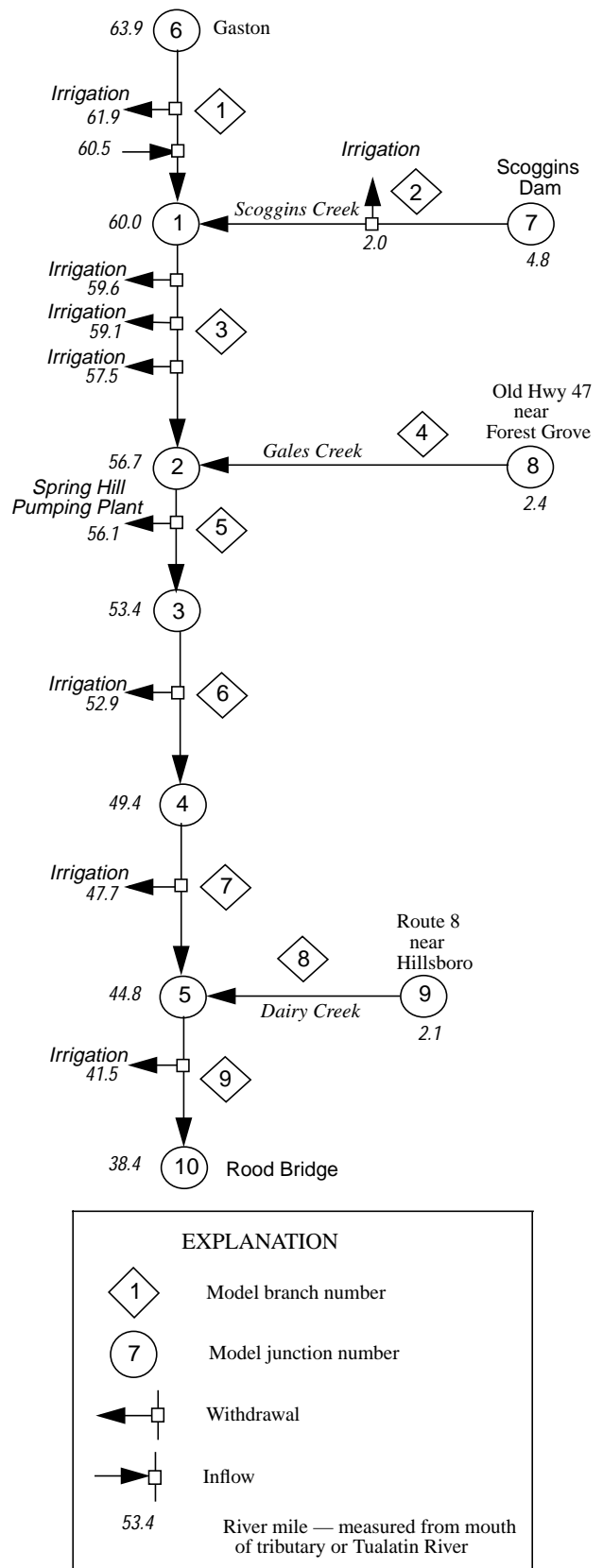

Figure 7. The Diffusion Analogy Flow/Branched Lagrangian Transport Model configuration for the Tualatin River, Oregon.

The final calibrated input file for DAFLOW, containing the model configuration parameters, initial discharges, and channel hydraulic parameters, is presented in Appendix E.

The DAFLOW input file also must include time-varying boundary-condition data for inflows and withdrawals to the stream network. Flows collected on the Tualatin River near Gaston, on Scoggins Creek below Henry Hagg Lake, on Gales Creek at Forest Grove, and on Dairy Creek at Route 8, along with estimated flows at Wapato Creek near Gaston, were used as upstream boundary conditions. Flows for Wapato Creek were estimated by multiplying flows from Gales Creek by the ratio of the Wapato Creek drainage area to the Gales Creek drainage area. Gales Creek flows were used as the basis for the estimation because that basin is relatively unregulated. In contrast, Wapato Creek flows are affected by irrigation withdrawals. As explained in detail below, some adjustments were made to these estimated flows during the calibration process.

Withdrawal flows for irrigation and domestic water supply were included at nine locations in the upper stream section. The most significant withdrawal was the Spring Hill Pumping Plant operated by the TVID at RM 56.1. This pumping plant supplies river water to a pipeline network for irrigation of approximately 10,500 acres of agricultural land. The plant is usually in operation from mid-May to mid-October. Withdrawal data collected at this site were gaged, calibrated, and checked by USGS personnel. In 1994, the peak withdrawal from the plant was in mid-July at almost 80 ft³/s. Additional withdrawals were made at this same location by the Joint Water Supply Commission. These withdrawals generally ranged from 20 to 50 ft³/s and were continuous throughout the year.

Major withdrawals also occurred at RM 61.9 in the most upstream branch. These flows were measured on a weekly basis by TVID.

Withdrawals were simulated at seven other locations to represent water taken directly out of the river by individual users to irrigate fields near the river. Because of the high number of individual users along the river, it was not practical to simulate separate, ungaged withdrawals from the model for every user at their withdrawal locations. Therefore, the model reach was divided into seven subreaches and all individual withdrawals within each subreach were summed into a single withdrawal. In the model, these summed withdrawals were located at a midpoint in each subreach.

The rate of withdrawal for irrigation was estimated as a fraction of the rate of pumping from the Spring Hill Pumping Plant and was based on the ratio of the number of acres in the subreach served by water rights to the number of acres irrigated from the Spring Hill Pumping Plant. This estimation method was based on the assumption that the seasonal water use per acre in the TVID network was similar to individual irrigation water use along the river. Water rights for the Tualatin River are issued by both TVID and OWRD. It was assumed that water rights for TVID-permitted acres were fully used. However, it also was assumed that water rights for the OWRD-permitted acres were only 50 percent expropriated (Jerry Rodgers, Watermaster, Oregon Water Resources Department, oral commun., 1995). The location of the simulated subreach withdrawal points and the number of TVID- and OWRD-permitted acres in each subreach are presented in table 2.

To test the performance of the models, simulated flows and temperatures were compared with flows and temperatures measured at several downstream locations. Within the upper stream section, from Rood Bridge to Gaston, flow and water-temperature data were continuously collected at three locations: Dilley (RM 58.8), Golf Course Road (RM 51.5), and Rood Bridge (RM 38.4). Calibration of the flow model was achieved by first calibrating the Gaston to Dilley reach, then the Dilley to Golf Course Road reach, and finally the Golf Course Road to Rood Bridge reach. To calibrate a reach, adjustments were made to the boundary-condition flows and withdrawals to make simulated flow converge with observed flow. Most adjustments were made to estimated irrigation withdrawals. Of all the boundary conditions, irrigation withdrawals had the greatest margin of error because of the difficulty in determining the percentage of water rights being expropriated. It was realized that other potential inflows and outflows in the river system that were not directly included in the model were groundwater flows, evapotranspiration, precipitation, small creeks, and springs. Thus, adjustments made to the irrigation withdrawals were assumed to take into account these other ungaged flows. These adjustments were legitimate because the location of the irrigation withdrawals were somewhat evenly distributed over the upper stream section like the other ungaged flows.

In the initial simulation of the most upstream reach, Gaston to Dilley, simulated flows were less than observed flows. This difference was eliminated by increasing the Wapato Creek flow by one-half of

Table 2. Irrigated acreage used to estimate water withdrawals in the upper stream section of the Tualatin River, Oregon [TVID, Tualatin Valley Irrigation District; OWRD, Oregon Water Resources Department; DAFLOW, Diffusion Analogy Flow model, BLTM, Branched Lagrangian Transport Model]

River Reach (river mile)	Acres served by TVID permits	Estimated acres served by OWRD permits	Estimated total irrigated acres	Withdrawal segment in DAFLOW and BLTM model configurations	
				Branch	Segment
61.8–60.0 ¹	140	302.2	442.2	3	2
60.0–58.0	334.9	274.0	608.9	3	4
58.0–56.0	206.7	461.2	667.9	3	10
56.0–51.1	579	1,326.3	1905.3	6	3
51.1–46.0	122.7	1,043.5	1166.2	7	7
46.0–38.5	597.8	1,618.2	2216.0	9	10
4.8–0.0 ²	228.2	.0	228.2	2	7

¹ Withdrawal segment was moved from branch 1 to branch 3 to improve the flow model performance.

² River mile distance from Scoggins Creek confluence.

the difference and decreasing the irrigation withdrawal by one-half of the difference. These adjustments were assumed reasonable because the values originally used for the Wapato Creek flow and that irrigation withdrawal had been only estimates. For the Dilley to Golf Course Road reach, initial simulated flows were also less than observed flows. The original estimates of irrigation withdrawals (not including Spring Hill Pumping Plant withdrawals) in this reach were decreased to minimize this difference. For the Golf Course Road to Rood Bridge reach, initial simulated flows also were less than observed flows, and the rate of irrigation withdrawals in this reach was decreased to minimize the difference between simulated and observed flows. As a result of these adjustments, the timing of the simulated and observed flows in each of these three reaches for May to November 1994 agreed well (fig. 8).

Heat Transport

The BLTM model configuration of branches and stream segments was the same that was used for the DAFLOW model (fig. 7). Most of the time-varying boundary conditions were also the same. Half-hourly water-temperature data, collected at the Gaston, Scoggins Creek, Gales Creek, and Dairy Creek stream-gaging sites, were used as boundary conditions for the BLTM model. Required meteorological data for the model included air temperature, dewpoint temperature, wind speed, and solar radiation. The air-temperature data were collected at the Rock Creek stream gage near Hillsboro. The dewpoint-temperature data were collected at the Hillsboro Airport. The wind-speed and solar-radiation data were collected at the Rock Creek WWTP. The Rock Creek solar-

radiation data were regressed with Scoggins Creek solar-radiation data for a units conversion to langleys per day. BLTM model configuration parameters, initial water temperatures for each stream segment, and time-varying temperature data for the boundary conditions are presented in Appendix F.

Water-temperature data were collected on the main stem at Dilley, Golf Course Road, and Rood Bridge. Similar to the flow model calibration, the BLTM model was calibrated in a downstream order reach by reach—Gaston to Dilley, Dilley to Golf Course Road, and Golf Course Road to Rood Bridge. To calibrate the heat-transport component of the BLTM model, iterative adjustments to the monthly stream-segment shading coefficients within the reach were made until the difference between simulated and observed water temperatures at the downstream end of the reach was minimized. All the stream-segment shading coefficients contained within a reach were adjusted by an equal percentage. The coefficients were held constant at 1.0 if they were adjusted positively.

The riparian shading coefficients were used to calibrate the heat-transport model because they were the only model parameters that were distributed by stream segment. All other parameters must be applied globally to the whole system. Also, as presented in equation 5, a shading coefficient is also a direct adjustment of the amount of incoming shortwave solar radiation allowed to reach the water body. Most of the energy flux in a stream typically occurs between the air/water interface (Brown, 1969).

It was necessary to adjust the initial stream-segment shading estimates, because riparian shading can vary greatly along a stream reach within only a few feet.

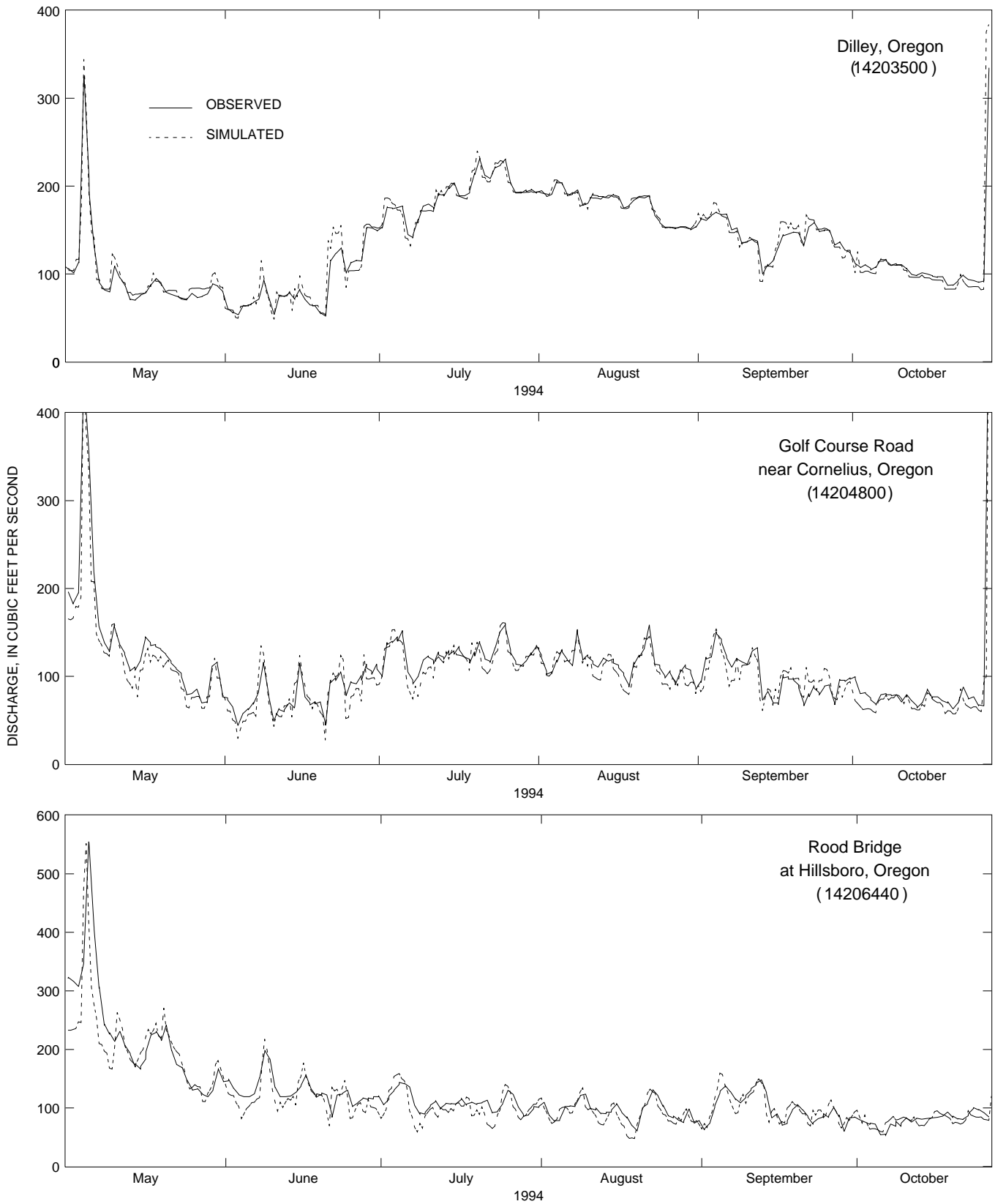

Figure 8. Observed and simulated discharge from May through October 1994 in the Tualatin River, Oregon.

Although numerous field measurements and detailed data from aerial photographs were used in conjunction with the SNTMP shade model to estimate the stream-segment shading coefficients, the shading estimates still had an un expectedly large margin of error. Most of the stream segments were within one-quarter to one-half mile in length, which would permit considerable riparian shading variation. It also was necessary to adjust the shading coefficients to correct spatial error in the shortwave solar-radiation data. Only a single solar-radiation-station time series could be used as data input to BLTM. Solar time-series data, collected at the centrally located Rock Creek WWTP, were for the entire study area. These data were not always representative of the actual spatial variation of solar light over the study area that can occur on cloudy days.

The final calibration plots of observed and simulated water temperatures at Dilley, Golf Course Road, and Rood Bridge are shown in figure 9. Table 3 shows the monthly adjustments made to the stream-segment riparian shading coefficients in the three reaches. The adjustments show some consistency with the physical conditions in the upper stream section. Some of the shading coefficients in the first reach were adjusted positively because of the closed canopy that exists along a narrower stream. However, the shading coefficients in the downstream reaches were decreased because the stream is wider. In a wider stream, riparian shading will affect a smaller fraction of the overall water surface.

Lower Stream Section Modeling

The lower stream section model extended from Rood Bridge (RM 38.4) to the low-head diversion dam at RM 3.4. Just as in the upper stream section, it was necessary to calibrate the flow component of the lower stream section model before the heat-transport component.

Flow

An accurate flow calibration, and ultimately an accurate heat-transport calibration, required accurate bathymetric cross-section, surface-water, ground-water, withdrawal, and meteorological data.

The bathymetric data were used to create the two-dimensional (vertical and longitudinal along the direction of flow) numerical grid as a mathematical

representation of the channel geometry. The numerical grid used in this study to represent the Tualatin River from RM 38.4 to RM 3.4 was developed in another study (S.A. Rounds, U.S. Geological Survey, unpub. data, 1995) and is composed of 155 segments and 16 layers (fig. 10). With the exception of the top four layers, most of the layers are 2 ft in thickness. During low-flow periods, the stream section from RM 29.7 to RM 3.4 is slow moving and resembles a long narrow lake more than it does a river. The 2-ft discretization was necessary to represent vertical gradients in temperature that can sometimes cause stratification. However, at the upstream end of the reach, where the flow cross section is thermally homogenous, a greater layer thickness was used. Most of the segments were 1,478 ft in length. The decision to use this length was based on the length scale for important bathymetric features and the need to minimize computer simulation time. A few segments were shorter than 1,478 ft because they represented unusually shallow or deep channel locations in the reach. The locations and dimensions of the segments used in the model for the entire lower stream section of the Tualatin River are presented in Appendix G.

The downstream boundary of the numerical grid is the low-head diversion dam at RM 3.4. The dam is composed of three structures that transmit flow: a broad, flat-crested, cement weir; a fish ladder; and a submerged “fish attractor” pipe located near the fish ladder. The hydraulic characteristics of these structures determine the flow rate over and through the dam for any given water-surface elevation behind the dam. Although the hydraulic characteristics of the fish ladder and the submerged “fish attractor” pipe are constant, characteristics of the cement weir do not remain constant over the summer. To maintain a sufficient water-surface elevation behind the dam to allow a gravity-fed flow through the Oswego Canal, personnel from the Lake Oswego Corporation erect wooden “flash boards” on the weir throughout the summer. The boards constrict flow and, if necessary, can be used to block the entire width of the cement weir. The effective width of the cement weir ranges from 0 to 188 ft. In October or November, when the river rises in response to stormflows, all the boards are taken down and left down until the following summer season. To simulate the variation in flows through this downstream boundary, model parameters that represent the weir characteristics were adjusted accordingly.

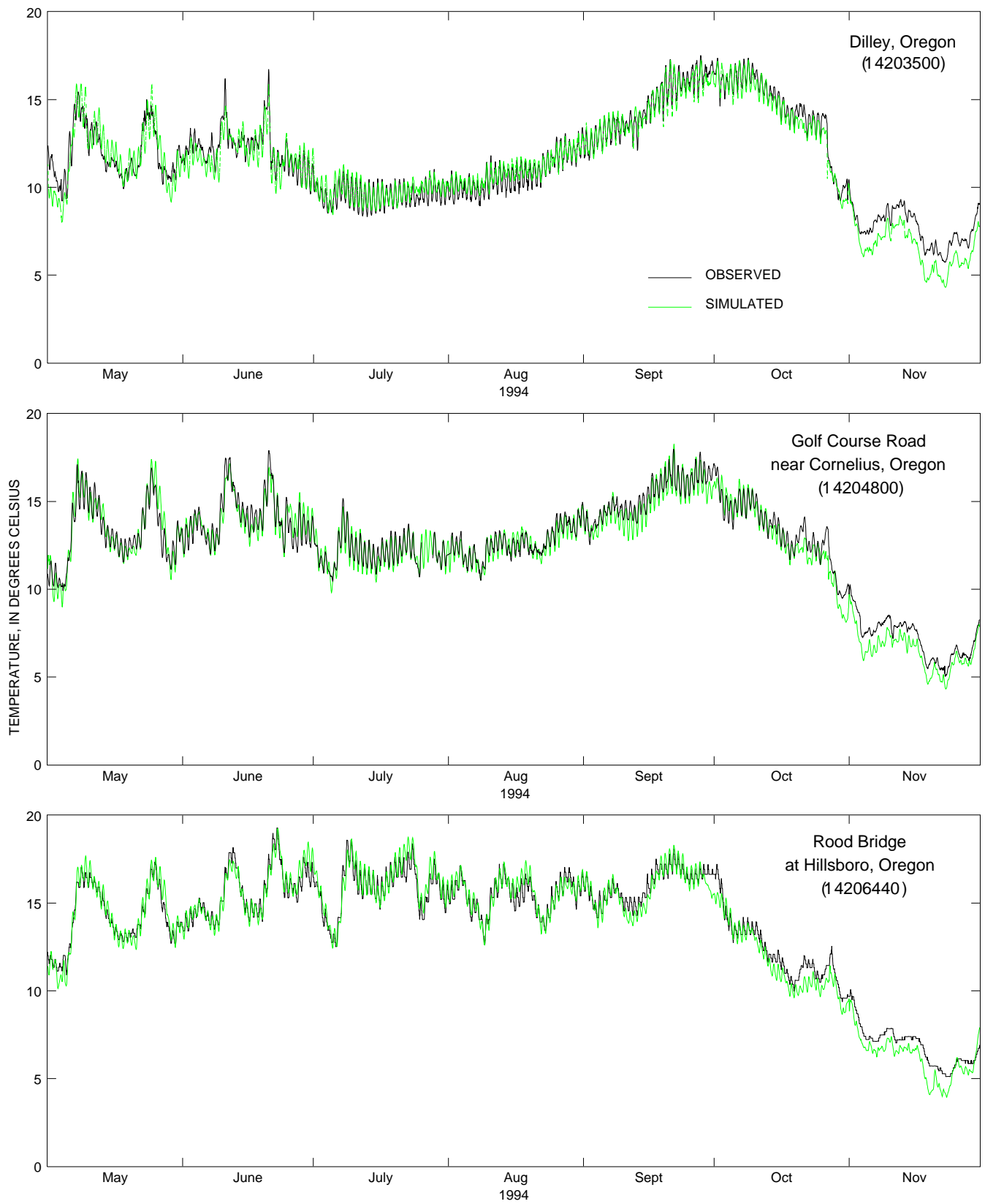

Figure 9. Observed and simulated water temperatures from May through November 1994 in the Tualatin River, Oregon.

Table 3. Percent adjustments made to riparian shading coefficients for calibration of the upper stream section transport model, Tualatin River, Oregon [RM, river mile]

Month	Percent Adjustmentt		
	RM 63.9 to RM 58.8	RM 58.8 to RM 51.5	RM 51.5 to RM 38.4
May	-40	-60	-60
June	-50	-70	-70
July	60	-60	-60
August	60	-60	-60
September	0	-60	-60
October	-60	-70	-70
November	-60	-70	-70

To accurately model flows in the lower stream section, all significant stream inflows and diversions were mapped as shown in figure 11. Half-hourly and hourly discharge data were available for the largest inflows, including the upstream boundary of the model on the main stem at Rood Bridge (RM 38.4), Rock Creek (north) and Fanno Creek near their confluences, and the Rock Creek and Durham WWTPs. For the smaller tributaries (which included Butternut Creek, Christensen Creek, Burriss Creek, Heaton Creek, McFee Creek, Rock Creek (south), Chicken Creek, and Nyberg Creek) estimates of weekly mean discharge were made by multiplying Rock Creek (north) weekly mean discharge times the ratio of the tributary's drainage area to the Rock Creek (north) drainage area.

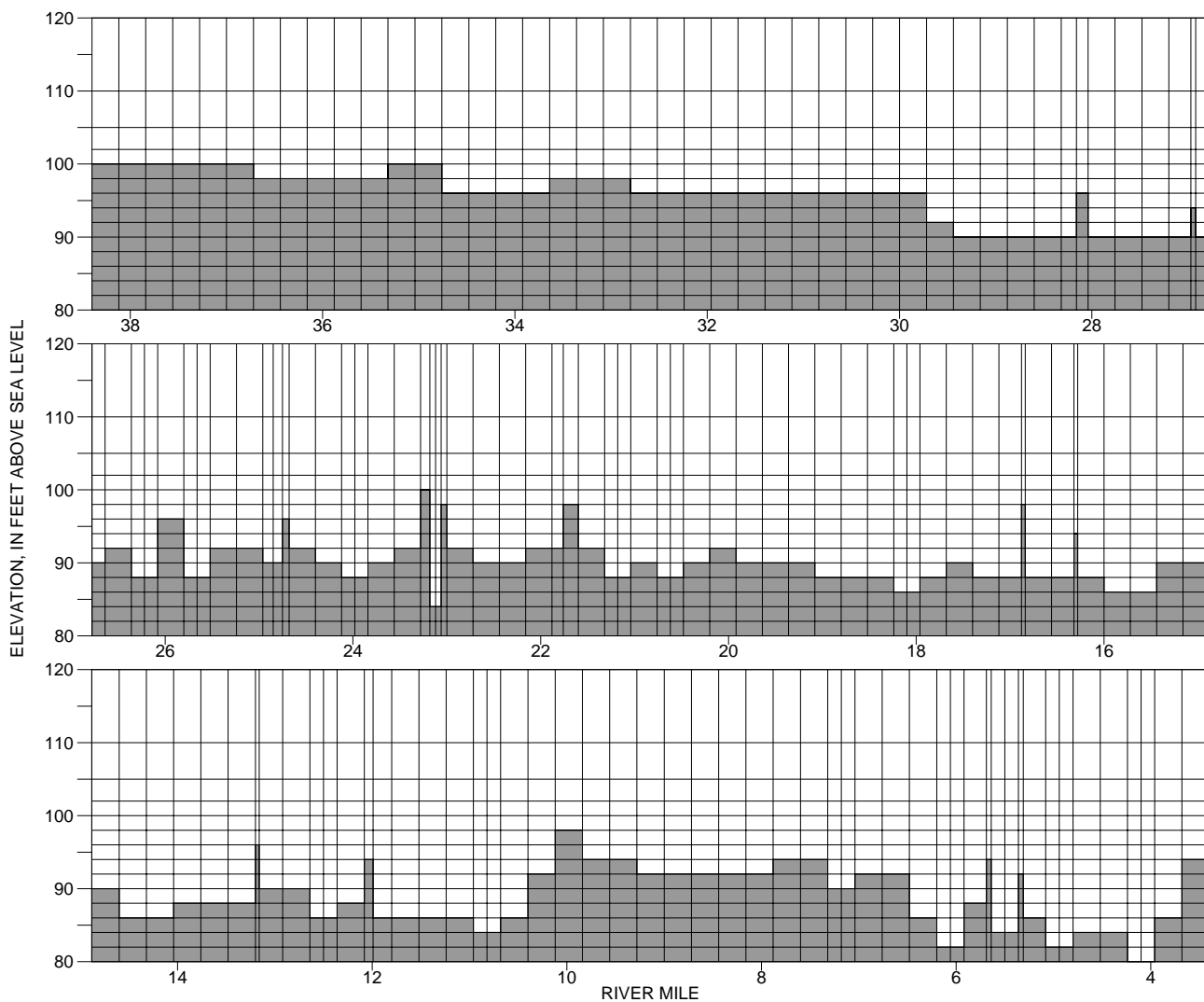

Figure 10. CE-QUAL-W2 model two-dimensional cell grid (layers 2 through 15) for the Tualatin River, Oregon, from river mile 38.4 to river mile 3.4.

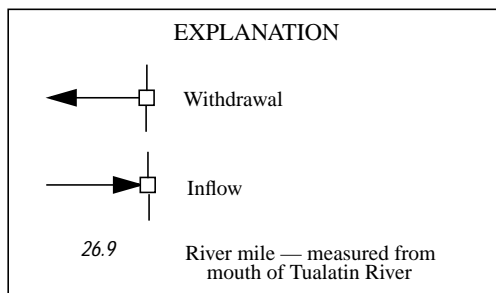
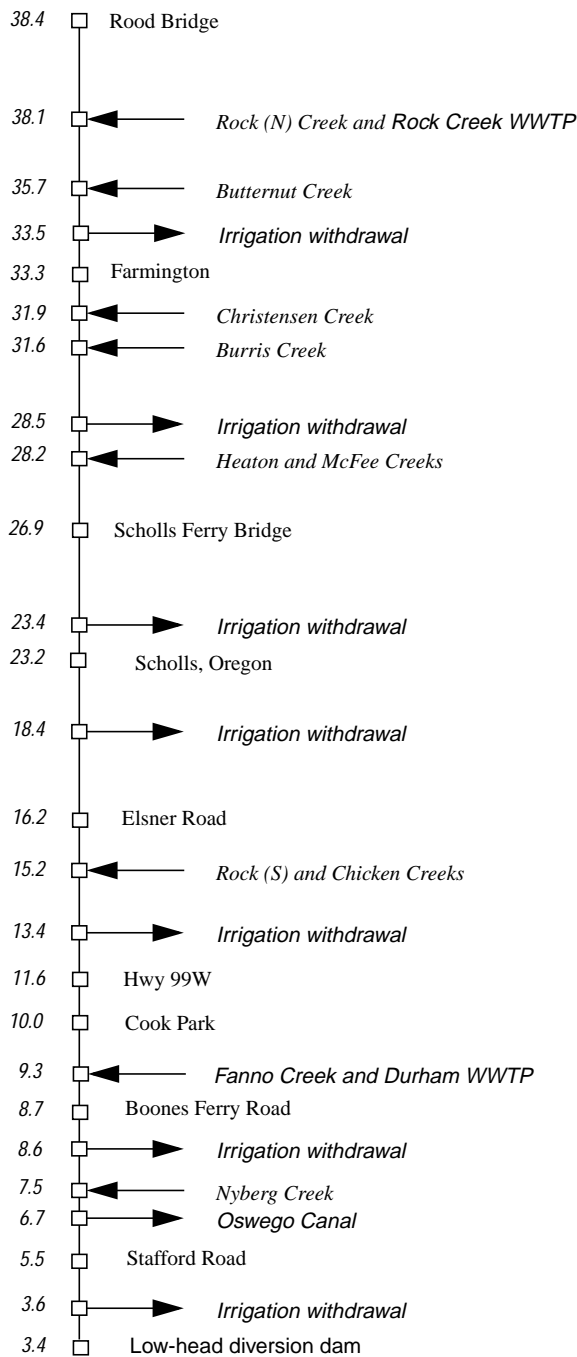

Figure 11. The CE-QUAL-W2 model configuration for the Tualatin River, Oregon.

The Rock Creek (north) Basin was used as a basis for these estimates because its land-use characteristics were similar to most of the smaller tributary basins. Precipitation data, collected at the Hillsboro Airport, also was included as a source in the model. Additional inflows to the model included discharges from ground water, seeps, tile drains, and small tributaries. Because it was impractical to measure these discharges throughout the entire model reach, their sum was estimated as a part of the calibration process, as discussed in more detail in a subsequent paragraph.

The most significant diversion from the lower stream section of the Tualatin River is at the Oswego Canal (RM 6.7). Irrigation withdrawals from the lower stream section also were considerable and were estimated using the same methodology described earlier for the upper stream section. The total number of acres served by TVID permits and OWRD permits along the river between RM 38.4 and RM 3.4 were compiled and divided into seven groups (as presented in table 4). In the model, a single withdrawal was made for each group at the downstream end of the reach of the group.

The rate of irrigation withdrawal for each of the seven groups was estimated as a fraction of the rate of pumping from the Spring Hill Pumping Plant and was based on the ratio of the number of acres in the group served by water rights to the number of acres irrigated by the TVID from the Spring Hill Pumping Plant. This estimation method was based on the assumption that the seasonal trend of irrigation water use per acre in the TVID network was similar to individual irrigation water use along the Tualatin River. Water rights for the Tualatin River are issued by both the TVID and the OWRD. It was assumed that water rights for the TVID-permitted acres were fully expropriated. However, it also was assumed that water rights for the OWRD-permitted acres were only 50 percent expropriated (Jerry Rodgers, Watermaster, Oregon Water Resources Department, oral commun., 1995).

Calibration of the flow component of CE-QUAL-W2 was based on the procedure used in another study (S.A. Rounds, U.S. Geological Survey, unpub. data, 1995). This calibration process involved adjusting model parameters to minimize the differences between simulated and observed stage at RM 6.7 and simulated and observed discharge at the downstream boundary. To calibrate the water-surface elevation behind the dam at RM 3.4, it was necessary to accurately determine time-varying values of the weir parameters. These parameters included the effective width of flow over the cement weir and a shape coefficient for the cement weir.

Table 4. Irrigated acreage used to estimate water withdrawals in the lower stream section of the Tualatin River, Oregon [TVID, Tualatin Valley Irrigation District; OWRD, Oregon Water Resources Department]

River Reach (river miles)	Acres served by TVID permits	Estimated acres served by OWRD permits	Estimated total irrigated acres	Withdrawal segment in CE-QUAL-W2 model segment
38.4–33.3	743	589	1,332	19
33.3–28.3	828	587	1,415	37
28.3–23.3	955	442	1,397	63
23.3–18.2	407	370	777	87
18.2–13.2	320	176	496	108
13.2–8.4	0	168	168	129
8.4–3.4	0	85	85	154

For the initial simulation, values for the effective flow width were based on notes taken by employees of the Lake Oswego Corporation, who documented the addition or removal of flash boards throughout the summer. During the calibration, continuous-stage data from the entrance of the Oswego Canal (RM 6.7) were compared to simulated water-surface elevations. The two weir parameters were adjusted until the difference between observed and simulated water-surface elevation was minimized.

After a calibrated simulation of the water-surface elevation was accomplished, it was possible to estimate the nonpoint contributions to the river (ground water, tile drains, seeps) by subtracting simulated discharge over the dam from observed discharge monitored at the West Linn gage (RM 1.8). For most of the simulation period, this difference was positive, as expected, indicating that additional inflow to the system was occurring. After the difference was smoothed using moving-average techniques, it was added to the model as a distributed inflow. A subsequent simulation showed a good agreement between observed and simulated flows for the entire simulation period. However, with the addition of more flow, simulated water-surface elevations increased, and it was necessary to make a final adjustment to the weir parameters.

In addition to accurately simulating flow volumes, it also was necessary to ensure that the stream velocities and dispersion were accurately simulated. In CE-QUAL-W2, the accuracy of simulated stream velocities (travel times) and dispersion are a function of the detail and accuracy of the bathymetric data and the estimates of the longitudinal-momentum dispersion coefficient (eddy viscosity), the longitudinal-

constituent dispersion coefficient (eddy diffusivity), and shear stresses from the air/water and sediment/water interfaces. Coefficients for eddy viscosity and eddy diffusivity were set to 1.0 square meter per second and 2.5 square meters per second, respectively. These values were determined through calibration by S.A. Rounds (U.S. Geological Survey, unpub. data, 1995) using dye-tracer information supplied by Lee (1995). For the air/water interface, wind shear was not a significant factor in controlling water velocity because of the relative narrowness of the river. For the sediment/water interface, a roughness coefficient (Manning's n) of 0.03 was used for all stream segments.

Heat Transport

Observed water-temperature data were used for the upstream boundary conditions of CE-QUAL-W2. Temperature data were collected every half hour at Rood Bridge and Rock Creek (north) and every hour at Fanno Creek. The temperature data at the Rock Creek and Durham WWTPs were collected every half hour. Because 1994 data were not available, daily and weekly 1992 temperature data were used for Butternut, Christensen, Burriss, Heaton, McFee, Rock (south), Chicken, and Nyberg Creeks. Flows from these tributaries were extremely low. Using 1992 temperature data should not have introduced significant error to the simulations. Required meteorological data for the model included air temperature, dewpoint temperature, wind direction, wind speed, and solar radiation. The air-temperature data were collected at the Rock Creek stream gage near Hillsboro. The dewpoint-temperature and wind-direction data were collected at the Hillsboro Airport. The wind-speed and solar-

radiation data were collected at the Rock Creek WWTP. The Rock Creek solar-radiation data were regressed with Scoggins Creek solar-radiation data for a units conversion to langleys per day.

To calibrate the heat-transport component of CE-QUAL-W2, temperature data collected half-hourly at Farmington (RM 33.3), Scholls (RM 23.2), Cook Park (RM 10.0), and hourly at the low-head diversion dam (RM 3.4) were compared with simulated water temperatures. With the exception of the low-head diversion dam site (RM 3.4), the temperature measurement sites were at relatively shallow reaches where vertical and horizontal temperature gradients were minimal. At the low-head diversion dam, simulated water temperatures from a mid-layer were compared with the observed temperature, which was measured at a mid-level.

Calibration to the heat budget in CE-QUAL-W2 followed the same procedure used to calibrate BLTM in the upper stream section. Iterative adjustments to the monthly stream-segment shading coefficients within each reach were made until the difference between simulated and observed water temperatures at the downstream end of the reach was minimized. The reaches included Rood Bridge (RM 38.4) to Farmington (RM 33.3), Farmington to Scholls (RM 23.2), Scholls to Cook Park (RM 10.0), and Cook Park to the low-head diversion dam (RM 3.4). All the stream-segment shading coefficients contained within a reach were adjusted by an equal percentage. The coefficients were held constant at 1.0 if they were adjusted positively. Table 5 shows the monthly percent adjustments made for stream-segment riparian shading coefficients in the four reaches.

Like the upper section heat-transport model, the heat-transport component of CE-QUAL-W2 contains a limited number of parameters that could be adjusted for model calibration. The version of CE-QUAL-W2 used in the study did not contain a bed-sediment component. Shading coefficients are the only heat-related parameters that are distributed by stream segment. Shading adjustments were necessary to account for spatial errors in the initial stream-segment shading estimates and in the shortwave solar-radiation data. Solar-radiation time-series data collected at the Rock Creek WWTP were the only solar data input for the entire model configuration. Although some of the shading coefficients for the stream segments in the lower reaches were adjusted positively by as much as 90 percent, the initial estimates for these coefficients were very low. The river is at its widest in these reaches.

Table 5. Percent adjustments made to riparian shading coefficients for calibration of the lower stream section transport model, Tualatin River, Oregon [RM, river mile]

Month	Percent Adjustment			
	RM 38.4 to RM 33.3	RM 33.3 to RM 23.2	RM 23.2 to RM 10.0	RM 10.0 to RM 3.4
	May	60	0	90
June	60	0	90	90
July	60	0	90	90
August	60	0	90	90
September	60	-60	0	0
October	0	-60	0	0
November	0	-60	0	0

Riparian shading affects a much smaller fraction of the entire water surface. Many of the trees along the lower reaches are Douglas fir conifers and are much taller than originally estimated for the SNTTEMP model.

Observed and simulated water temperatures for the Farmington (RM 33.3), Scholls (RM 23.2), Cook Park (RM 10.0), and low-head diversion dam (RM 3.4) sites are shown in figure 12. Model results for the most upstream site (Farmington at RM 33.3) showed the best agreement between observed and simulated values. This was expected due to the short travel time in this reach. Nonetheless, for all four sites, simulated temperatures appear to overlay observed temperatures fairly well most of the time. Although simulated temperatures did not agree with observed temperatures every day, many of the measured diel and seasonal variations were simulated quite accurately. The greatest mean daily difference between simulated and observed temperatures was less than 3°C and most of the time was less than 1°C. One source of the error could be related to the inability of this version of the model to simulate heat conduction through the sediment/water interface.

MANAGEMENT SCENARIO SIMULATIONS

The third objective of the study was to assess the impact of various management practices on stream temperatures during the low-flow season. An approach often used involves calibrating a model with observed data and then operating the calibrated model under a variety of hypothetical scenarios. Hypothetical scenarios can be developed using either a mixture of actual and synthetic data sets or data sets that are entirely synthetic. The ability of a model to accurately simulate a hypothetical scenario is a function of the model's "robustness."

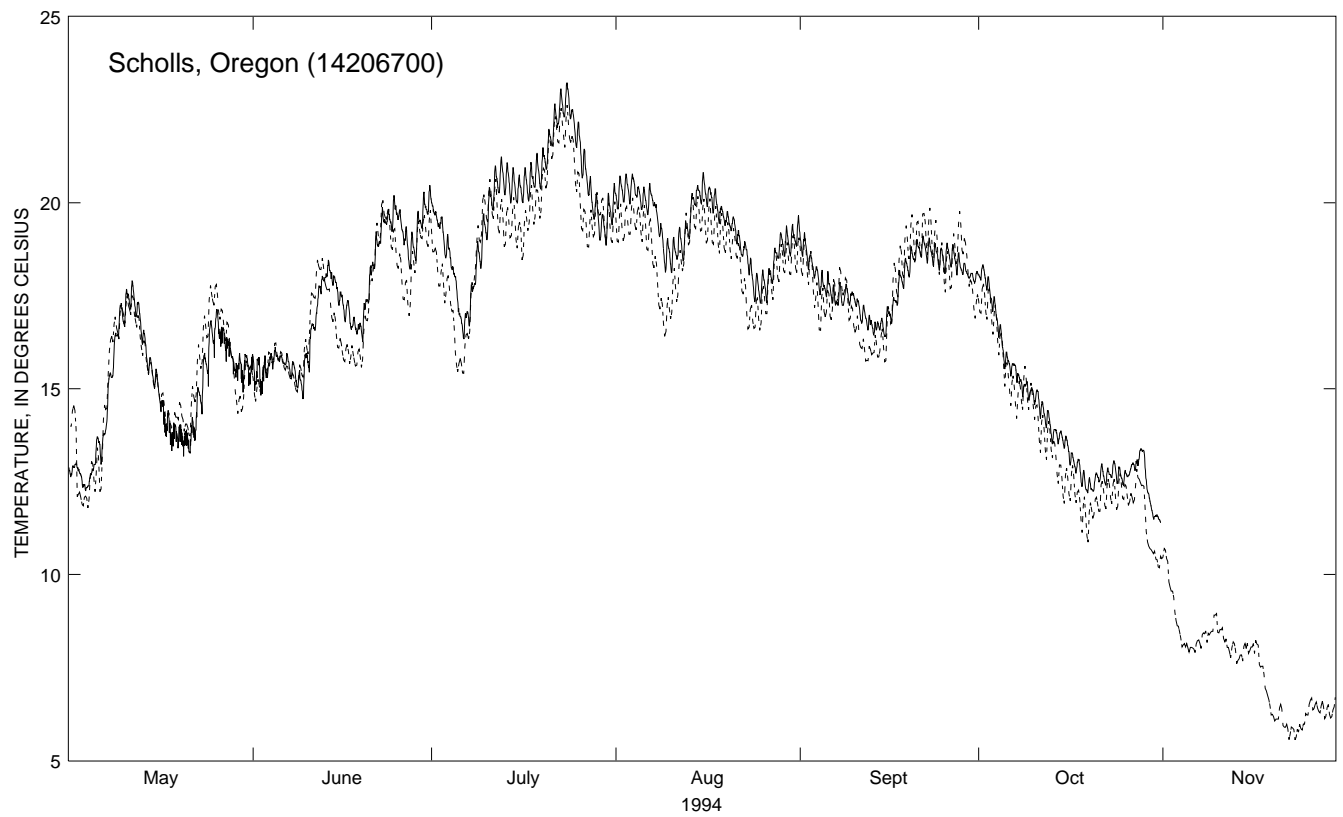
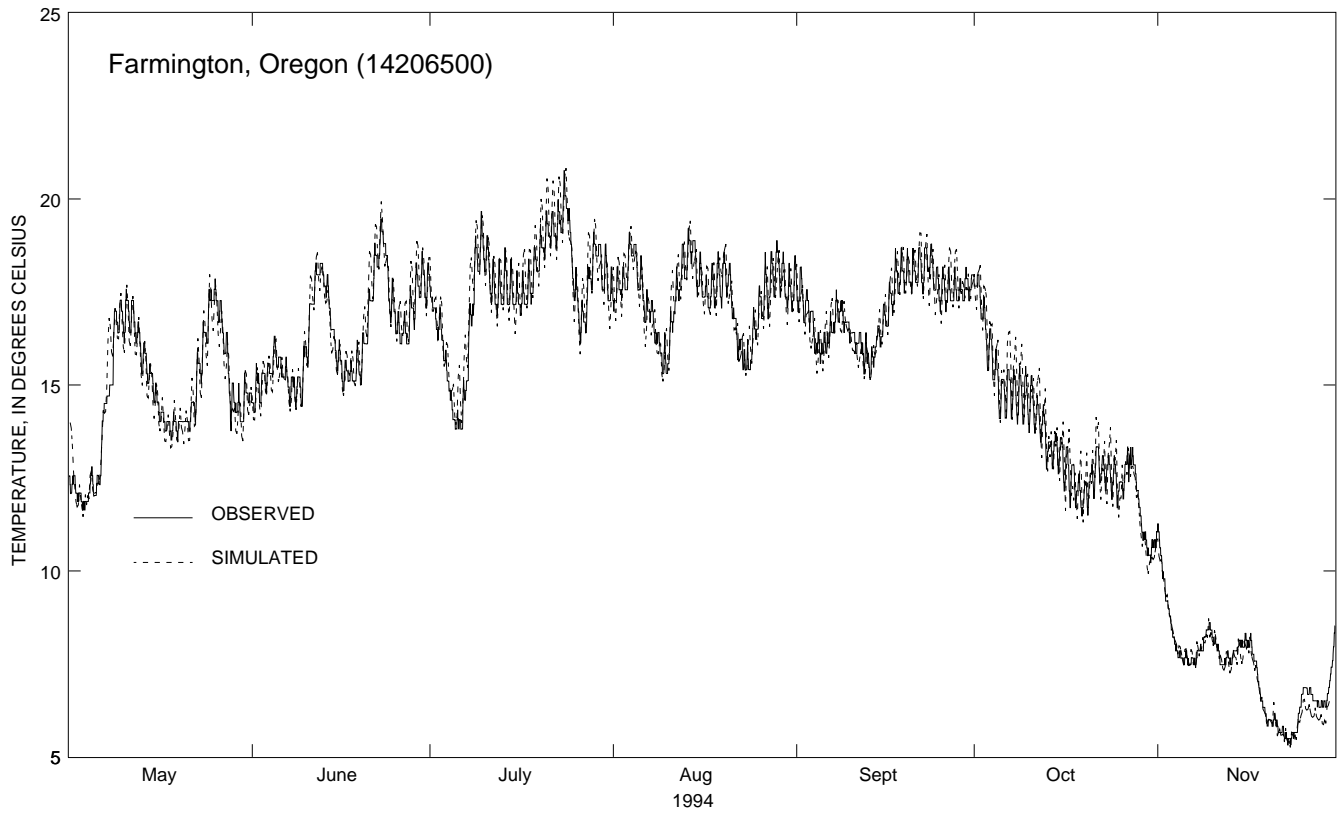

Figure 12. Observed and simulated water temperatures from May through November 1994 in the Tualatin River, Oregon.

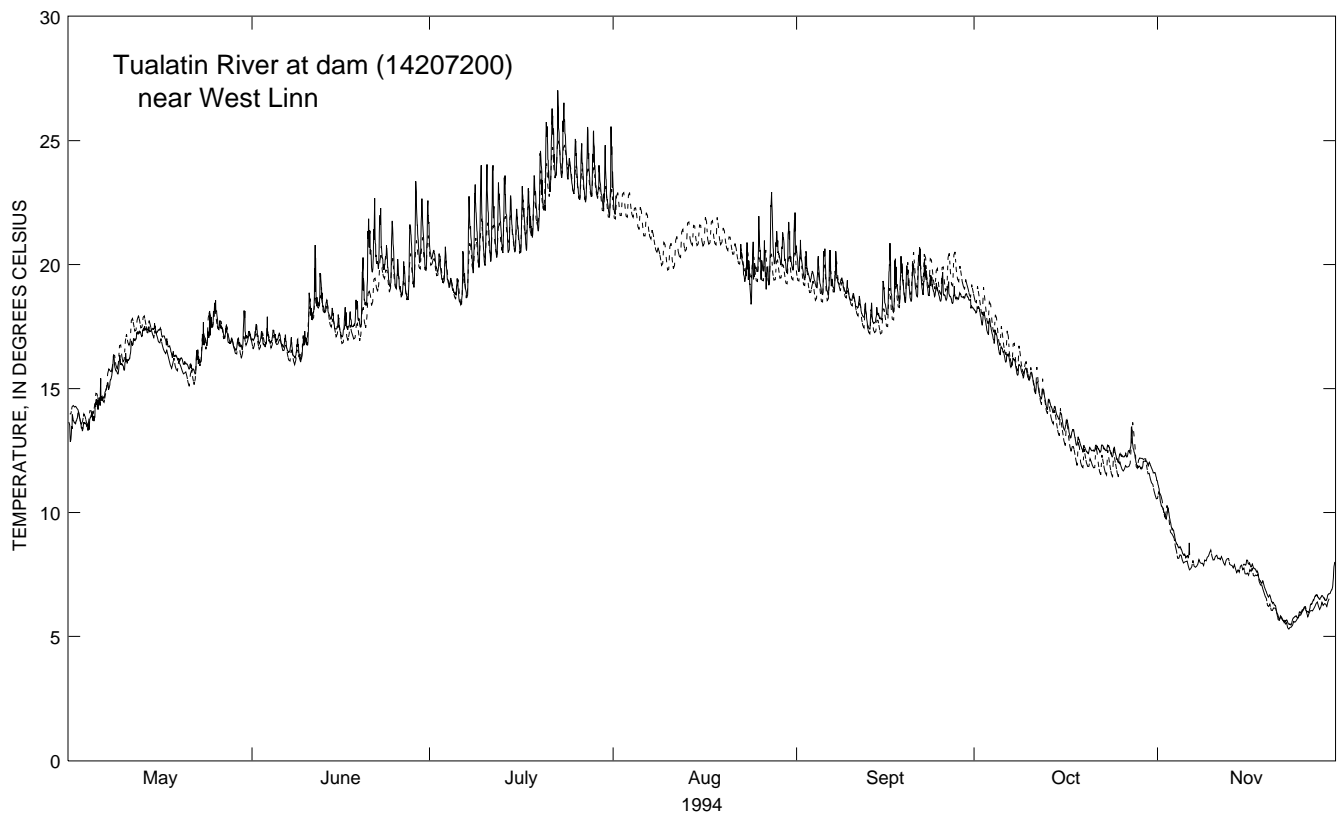
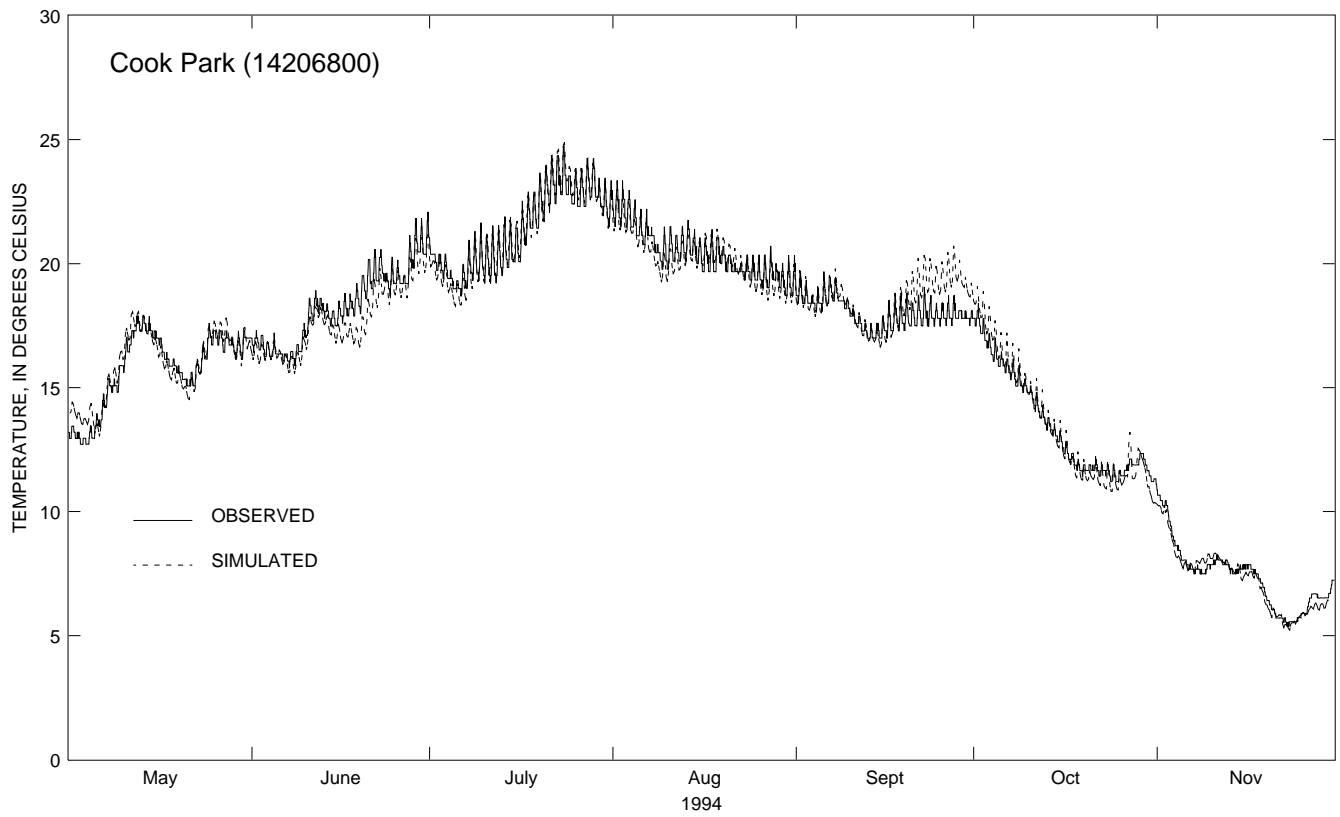

Figure 12. Observed and simulated water temperatures from May through November 1994 in the Tualatin River, Oregon—Continued.

A model is robust if it can accurately simulate the extremes in a data set. The robustness of a model can be considered to increase with the quantity and variation of the data used for calibration. For this study, only 1 year of data, 1994, was used to calibrate the models. Many of the management practices tested in the scenarios were never used during the period in which the data were collected. Nonetheless, the operation of the models under a wide range of conditions can provide managers with an insight into the overall response of the Tualatin River system.

Scenario Descriptions

A brief description of each of the simulated hypothetical scenarios is provided in table 6. A more complete description of each scenario follows.

Scenario 1: Existing conditions—Most of the conditions used in this scenario were the same that were used to calibrate the upper and lower section models. Seven months of observed 1994 meteorological, flow, and water-temperature time-series data were used for the upstream tributary boundaries to the models. The same monthly shade coefficients and channel hydraulic parameters used in the final calibration simulation also were used in this scenario. However, unlike the calibration simulations, the upper and lower stream section models were linked by using simulated flow and water temperature at Rood Bridge from the DAFLOW and BLTM models as upstream boundary condition data for the CE-QUAL-W2 simulation.

Scenario 2: Existing conditions without Unified Sewerage Agency allotted flows—The USA owns the water rights to 12,900 acre-feet per year of storage in the Henry Hagg Lake reservoir. This water is used to maintain adequate flow in the river to mitigate the water-quality impacts of the WWTP effluent. For this scenario, the same existing conditions used in the first scenario were simulated, except allotted flows for the USA were not released from Henry Hagg Lake reservoir. Water deliveries for the USA from the dam to the river change on a daily basis, and the amount in 1994 was based on a goal of maintaining a minimum flow at Farmington of 150 ft³/s. During unusually dry summers such as in 1992, the goal had to be lowered to 120 ft³/s. In 1994, USA water deliveries began in mid-June, reached a maximum level of about 75 ft³/s in late July, and ended in late October. To simulate what the Henry Hagg Lake reservoir release flows would have been, the daily USA water deliveries were

simply subtracted from the Scoggins Creek observed flow time series record.

Scenario 3: “Natural” conditions—The purpose of this scenario was to estimate the spatial and temporal water-temperature variations in the Tualatin River in the absence of current regulation of the river. However, replicating completely natural conditions in the river basin was not feasible with the calibrated models. Prior to the arrival of non-Native American settlers, many of the low lying areas along the Tualatin River were wetlands filled with woody debris. Over the past 150 years, inhabitants of the basin have built dikes, drained fields, and deepened the river channel (Cass and Miner, 1993). The flood plain and channel hydraulic characteristics in the calibrated models, therefore, are not an accurate representation of the basin prior to development. The temperatures and hydrologic regime of the boundary tributaries entering the river also have been altered by agriculture and urbanization in the upland regions. Nonetheless, by simply “turning off” many of the current flow management practices in the river basin, a rough estimate of natural conditions in the basin was simulated.

The simulation of “natural” conditions was based on the following assumptions:

- (1) No flow augmentation from the Trask River (Barney Reservoir) to the main stem of the Tualatin River was provided.
- (2) Both Henry Hagg Lake reservoir and the low-head diversion dam at RM 3.4 were assumed not to exist.
- (3) No withdrawals for irrigation or urban water supply were made.
- (4) No flow diversions for the Oswego Canal were made.
- (5) No effluent was released from wastewater-treatment plants.
- (6) Maximum possible vegetative shading along the main stem and tributaries was assumed.

An approximate estimation of flow in Scoggins Creek without the Henry Hagg Lake reservoir was made by combining the measured flows of creeks upstream of the reservoir. The three most significant inflows to the reservoir are Scoggins, Sain, and Tanner Creeks. Continuous flow data were collected in 1994 at gages on each creek. The basins of the creeks are unregulated and mostly forested.

Table 6. Hypothetical management scenarios, Tualatin River, Oregon
 [USA, Unified Sewerage Agency; RM, river mile; WWTP, wastewater-treatment plant]

Scenario number	Title	Description
1	Existing conditions	Observed and simulated 1994 meteorologic, flow, shade, and hydraulic data were used as input to the models to determine spatial and temporal temperature variations along the main stem of the river.
2	Existing conditions without USA allotted flows	Existing conditions used in scenario 1 were simulated except allotted flows for the USA were not released from Henry Hagg Lake reservoir.
3	“Natural” conditions	No flow augmentation from Trask River was provided. Both Henry Hagg Lake reservoir and the low-head diversion dam at RM 3.4 were assumed to not exist. No withdrawals for irrigation, urban water supply, or the Oswego Canal were made. No effluent was released from wastewater-treatment plants. Maximum possible shading along the main stem and tributaries was assumed.
4a	No shading	Existing conditions used in scenario 1 were simulated except no vegetative shading along the main stem and the tributaries was used.
4b	Maximum shading	Existing conditions used in scenario 1 were simulated except maximum possible vegetative shading along the main stem and the tributaries was used.
5	Existing conditions without the low-head diversion dam at RM 3.4	Existing conditions used in scenario 1 were simulated except the the low-head diversion dam at RM 3.4 was assumed to not exist.
6	Existing conditions with tributary temperature reduction	Existing conditions used in scenario 1 were simulated except the temperatures of all upstream tributary boundaries, except Scoggins Creek, were reduced by 2 degrees Celsius.
7	Existing conditions without WWTPs	Existing conditions used in scenario 1 were simulated except no effluent was released from either the Rock Creek or Durham WWTPs.
8	Existing conditions without USA allotted flows, lower section withdrawals, and WWTPs	Existing conditions used in scenario 1 were simulated except allotted flows for the USA were not released from Henry Hagg Lake reservoir, withdrawals for irrigation and the Oswego Canal were not made in the lower stream section, and no effluent was released from either the Rock Creek or Durham WWTPs.
9	Existing conditions without the low-head diversion dam at RM 3.4 and WWTPs	Existing conditions used in scenario 1 were simulated except the low-head diversion dam at RM 3.4 was assumed to not exist and no effluent releases were made from either the Rock Creek or Durham WWTPs.
10	Existing conditions with tributary temperature reduction and without WWTPs	Existing conditions used in scenario 1 were simulated except the temperatures of all upstream tributary boundaries, except Scoggins Creek, were reduced by 2 degrees Celsius and no effluent was released from either the Rock Creek or Durham WWTPs.

Simulating the Tualatin River without the low-head diversion dam at RM 3.4 required three separate simulations, using the lower stream section model. In the first simulation, the entire configuration (Rood Bridge to the low-head diversion dam) was simulated to create time-series files of simulated flow and temperature at Cook Park (RM 10.0). For this simulation, the dam was still included as part of the model configuration; however, the flash boards were kept down for the entire simulation period. The second and third simulations were made for two separate reaches: from Rood Bridge to Cook Park and Cook Park to the low-head diversion dam. It was necessary to divide the original model configuration into these two parts because a shallow bedrock sill in the river near Cook Park became a controlling influence when the water levels decreased as a result of dam removal. The simulated flow and temperatures at Cook Park, from the first simulation, were used as boundary condition data for the Cook Park to the low-head diversion dam simulation. In this latter simulation, the effect of the low-head diversion dam was removed entirely by setting the level of the outlet to the level of the channel bottom, effectively decreasing water levels by 4 ft.

Scenario 4: Extremes of riparian shade conditions—Conditions used in this scenario were the same as those used in the first scenario, except that variations were made to the amount of vegetative shading, which changed the amount of incoming shortwave radiation to the heat budget. Two extremes in vegetative shading were simulated: no shading and maximum potential shading along the entire main stem and parts of the tributaries. For maximum potential shading, riparian areas for each segment were assumed to have a maximum density of mature trees; monthly shading coefficients for each stream segment were computed by the SNTMP model.

Scenario 5: Existing conditions without the low-head diversion dam at RM 3.4—In this scenario, all existing conditions used in the first scenario were simulated except that the low-head diversion dam was assumed not to exist. This scenario was simulated to determine how the change in river hydraulics and travel time in the lower section of the river would impact water temperatures.

Similar to the “natural” conditions scenario described above, simulating the Tualatin River without the low-head diversion dam required dividing the lower model into two sections—Rood Bridge to Cook Park, and Cook Park to the low-head diversion dam. Separate simulations were required for each section.

Although the water elevation was reduced near the Oswego Canal entrance, it was assumed that there was no change in flow from the river to the canal, because flows through the canal are protected by water rights owned by the Lake Oswego Corporation. The flows are used to produce hydroelectric power. If the dam did not exist, water from the Tualatin River might have to be pumped into the canal to maintain flow, because the water right could still be used.

Scenario 6: Existing conditions with tributary temperature reduction—In this scenario, the existing conditions used in the first scenario were used, except that the temperature of almost all the tributary flows to the models was reduced by 2°C for their entire periods of record. Temperature was not reduced for Scoggins Creek flows. These flows come directly from the reservoir and are already relatively low.

The purpose of this scenario was to determine how far downstream in the main stem the impact of cooler tributary inflows would persist. If cooler tributary waters resulting from increased riparian shading in the upland basins were able to keep the main stem cooled, riparian reforestation efforts concentrated in the upland basins, rather than along the main stem, would be a reasonable management strategy. Otherwise, reforestation efforts to cool the Tualatin River would be necessary in both the upland basins and along the main stem.

Scenario 7: Existing conditions without wastewater-treatment plants—To determine the combined impact of the Rock Creek and Durham WWTPs on the Tualatin River water temperature, the same conditions used for the first scenario were used, except that effluent flow from the WWTPs was omitted.

Scenario 8: Existing conditions without Unified Sewerage Agency allotted flows, lower stream section withdrawals, and wastewater-treatment plants—Existing conditions used in scenario 1 were simulated except USA allotted flows were not released from Henry Hagg Lake reservoir, withdrawals for irrigation and the Oswego Canal were not made in the lower stream section, and no effluent was released from either the Rock Creek or Durham WWTPs.

Scenario 9: Existing conditions without the low-head diversion dam at RM 3.4 and wastewater-treatment plants—This scenario was simulated to determine the combined results of scenarios 5 and 7. Existing conditions used in scenario 1 were simulated except that the low-head diversion dam was assumed to not exist and no effluent releases were made from either the Rock Creek or Durham WWTPs.

Scenario 10: Existing conditions with tributary temperature reduction and without wastewater-treatment plants—This scenario was simulated to determine the combined results of scenarios 6 and 7. Existing conditions used in scenario 1 were simulated except the temperature of all upstream tributary boundaries (except for Scoggins Creek) were reduced by 2°C and no effluent was released from either the Rock Creek or Durham WWTPs.

Scenario Results

The simulation period for all the scenarios was May 1 through November 30, 1994. To interpret the significance of the scenario simulation results, it is necessary to understand how 1994 simulation period compared climatically with other years. Water-temperature data for 1991–94, collected at the low-head diversion dam near West Linn (14207200), (RM 3.4) are shown in figure 13. Monthly mean water temperatures at this site for 1994 were within 1.1°C of the 4-year mean monthly water temperatures in months for which a 4-year mean could be calculated (table 7). Daily air-temperature data (the mean of maximum and minimum observations) collected during the same 4-year period at the Hillsboro Airport near Hillsboro, Oregon, are shown in figure 14.

Monthly mean air temperatures collected at this site in 1994 were within 2°C of the long-term mean monthly air temperatures (1948–96), with the exception of November (table 8). Four months out of the 7-month 1994 season were warmer than the long-term mean, while the other 3 months were cooler.

Under the adopted State standards for waterways like the Tualatin River, a point-source discharge is not permitted to raise the temperature of the receiving water body if the receiving body already has a temperature of 17.8°C or above on the basis of a 7-day moving average of daily maximum temperatures. Model output is presented and scenario simulation results were interpreted in light of this temperature criterion. In each scenario simulation, water temperatures from the BLTM model were output for every segment in the upper stream section (RM 63.9 to RM 38.4) for every 30-minute time step. Also, for each scenario simulation, mean water temperatures of the upper 10 ft of every segment in the lower reach (RM 38.4 to RM 3.4) were output from the CE-QUAL-W2 model 5 times each day. The 7-day moving average of daily maximum water temperature was then computed for every segment for the entire 7-month simulation period. Monthly mean values were calculated from these time series of daily values.

Table 7. Water temperature data from the low-head diversion dam at river mile 3.4 near West Linn, Oregon, 1991–94 [Data for 1991–93 from Doyle and Caldwell, 1996. All values are in degrees Celsius. Values in first four rows are monthly mean temperatures. Values in the fifth row are means of the first four rows. ---, missing data]

Year	May	June	July	August	September	October	November
1991	---	16.2	21.2	21.4	18.3	14.2	9.8
1992	17.0	20.9	21.5	21.4	17.9	14.5	10.0
1993	15.3	17.3	18.8	20.8	---	14.4	8.5
1994	15.9	18.3	22.0	---	18.7	14.3	---
4-year mean	---	18.2	20.9	---	---	14.4	---

Table 8. Air-temperature data from the Hillsboro Airport near Hillsboro, Oregon [All values are in degrees Celsius. Values in first four rows are monthly mean temperatures. Values in the fifth row are means of the first four rows. Values in the last row are mean monthly temperatures from 1948 to 1996. Source: Oregon Climate Service.]

Year	May	June	July	August	September	October	November
1991	11.8	14.8	19.3	20.0	18.0	12.0	7.9
1992	15.8	18.7	20.2	19.8	15.7	12.7	7.3
1993	15.6	15.9	16.6	19.2	17.4	13.2	3.7
1994	14.6	15.9	20.2	19.2	18.3	10.5	4.5
4-year mean	14.5	16.3	19.1	19.6	17.4	12.1	5.9
Long-term mean	13.4	16.4	19.1	18.9	16.6	11.7	7.1

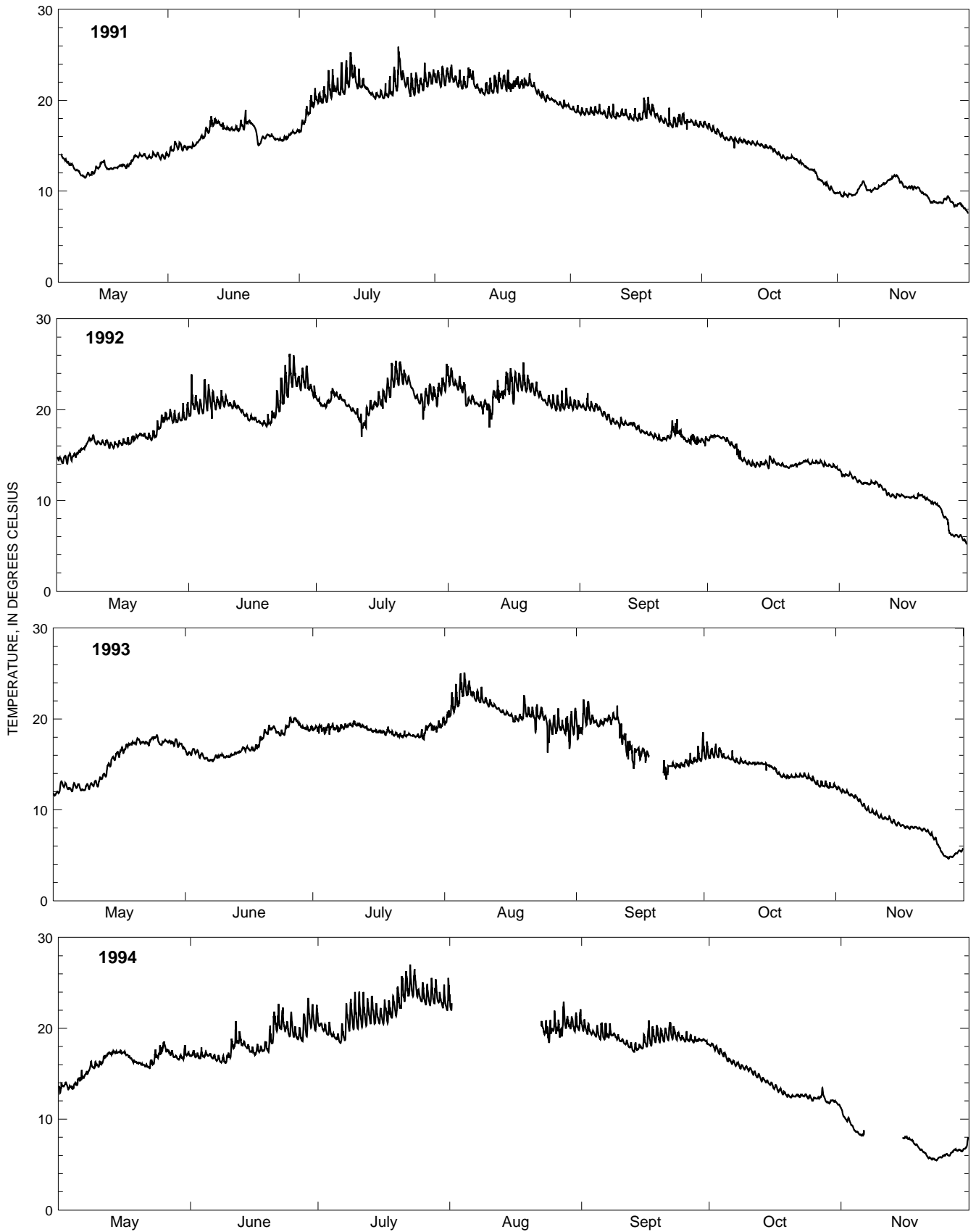

Figure 13. Observed hourly water temperature at the low-head diversion dam at river mile 3.4, Tualatin River near West Linn, Oregon (14207200), from May through November 1991–94. (Data for 1991–93 from Doyle and Caldwell, 1996.)

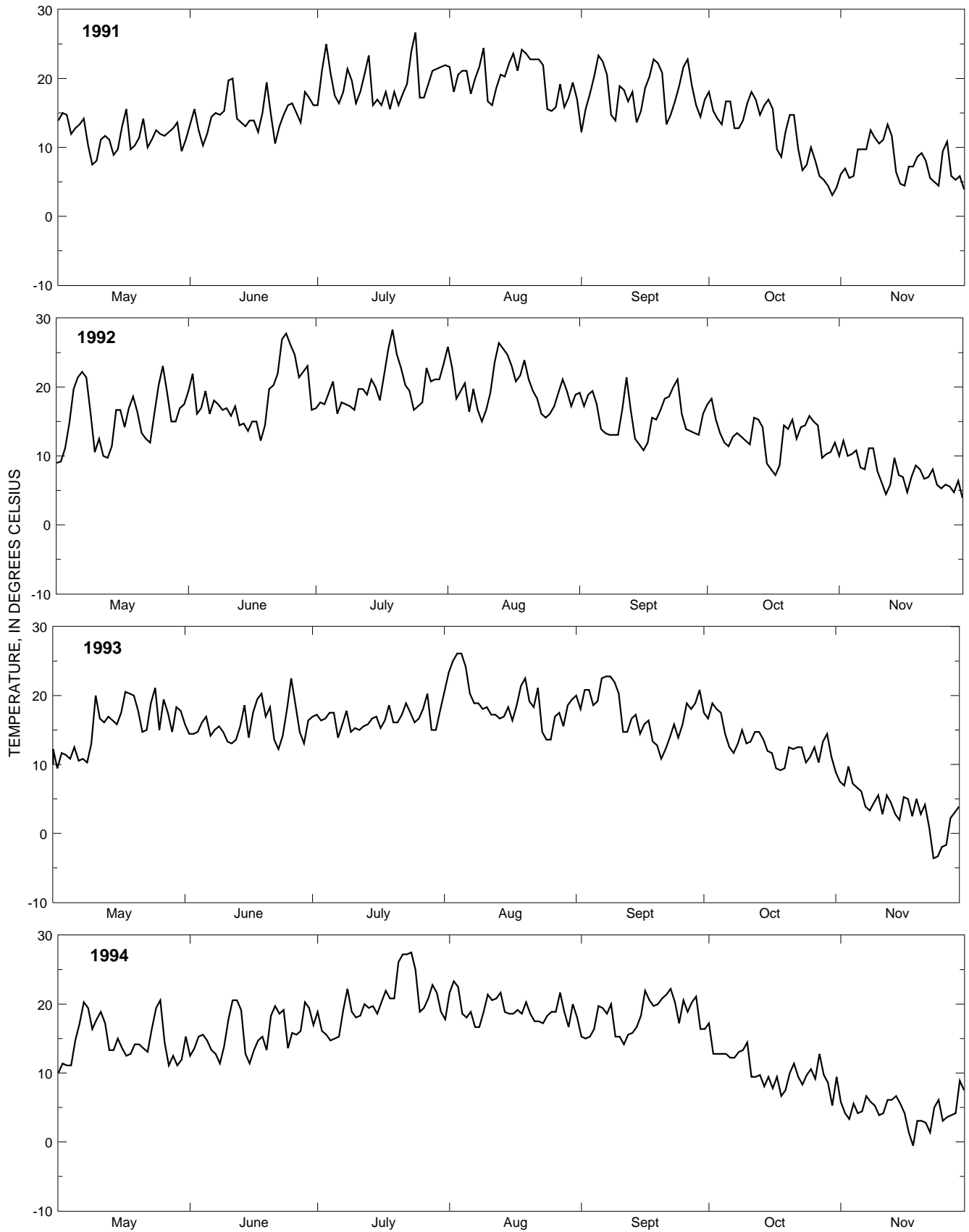

Figure 14. Mean of the daily minimum and maximum observed air temperature at the Hillsboro Airport near Hillsboro, Oregon, from May through November 1991–94. (Data from the Oregon Climate Service.)

The monthly mean values for each segment for all the scenarios are shown in figures 15 through 25. Individual graphs are shown for the months of May through October. A graph for November is not shown in any of the figures, because temperatures in November were consistently below the adopted criterion of 17.8°C for the entire river reach (RM 63.9 to RM 3.4). Flows in November 1994 also were considerably higher than in the prior 6 months and were not representative of the low-flow period.

Many of the graphs in figures 15–25 indicate erratic temperature fluctuations in the lower section of the river below RM 27. From this location down to RM 3.4 (low-head diversion dam), the river is more reservoir-like and thermally stratified. The two-dimensional CE-QUAL-W2 model accounts for thermal stratification and channel depth variations in the simulation. Dips in the graphs correlate to known shallow locations in the river. The model simulates the upwelling of cooler waters from the lower layers in the pools just upstream of the shallow sills. Thus, the water flowing over the sills are simulated as cooler than the pools.

Water temperatures averaged over the entire river reach (RM 63.9 to RM 3.4) for a given month and a given scenario are presented in table 9. The table also shows the change in degrees Celsius of the mean water temperature for a given scenario and the corresponding mean water temperature of the first scenario (which represents existing conditions).

Scenario 1: Existing conditions—Model simulations under existing conditions are shown in figure 15. The figure contains graphs of the mean 7-day moving average of daily maximum simulated water temperatures, plotted by river mile, for each month from May through October. For comparison, the figure also shows the mean 7-day moving average of daily maximum observed water temperatures at eight locations (table 1 and fig. 3). In general, the simulated water temperatures were within 1°C of the observed values. The observed value for June was slightly greater than 1°C larger than the simulated value for June at the low-head diversion dam at RM 3.4. Because of thermal stratification at the dam, it was difficult to measure water temperature at a location that would represent mean water temperature. Water temperature data at the low-head diversion dam for July and August 1994 were not available.

As shown in figure 15, the model predicts elevated water temperatures for July, August, and September near Gaston at RM 63.9. Water temperature data collected at this location were the upper boundary conditions to the model. Upstream of this location, the river flows through many exposed reaches in Patton Valley; the exposure causes water temperatures to rise during the summer months. The figure also shows the immediate cooling effect of inflow from Scoggins Creek (RM 60) (except in October, when it becomes a warming influence). At RM 38.1, the impact of effluent from the Rock Creek WWTP also is apparent. Farther downstream, water temperatures continue to increase and approach equilibrium temperatures. At RM 9.3, the impact of effluent from the Durham WWTP becomes evident.

Scenario 2: Existing conditions without Unified Sewerage Agency allotted flows—The impact of withholding USA allotted flow releases from Henry Hagg Lake reservoir is shown in figure 16. Less flow from Scoggins Creek results in warmer water in the main stem. Relative to scenario 1, the water temperatures averaged over the entire river reach increase 0.8 and 0.9°C in July and August, respectively. Violation of the 17.8°C criterion occurs at locations farther upstream. However, downstream of RM 15, temperatures return to the scenario 1 levels.

Scenario 3: “Natural” conditions—Under the “natural” conditions scenario, water temperatures averaged over the entire river reach increased by 1.4°C and 1.0°C, respectively, in July and August compared with the existing conditions scenario. In this scenario, there were no cool water releases from Henry Hagg Lake reservoir. However, mean water temperatures decreased in the other months. As shown in figure 17, temperatures in the upper stream section above (RM 38.4) generally were maintained below the 17.8°C criterion under natural conditions. However, temperatures in the lower stream section continually rise at most locations closer to the mouth. In the lower section, riparian vegetation shades less of the water surface, because the river is wider and velocities are slower than in the upper stream section. From Rood Bridge (RM 38.4) downstream, the water temperatures were above the 17.8°C criterion for the months of July and August. The 17.8°C criterion was surpassed downstream from RM 20 in September and from RM 10 in June.

Table 9. The 7-day moving average of daily maximum simulated 1994 water temperature in degrees Celsius for each management scenario during each month averaged over the reach from river mile 63.9 to river mile 3.4, Tualatin River, Oregon
 [First row of the scenario shows the mean water temperature of the reach in degrees Celsius; second row shows the change in the mean water temperature of the scenario in relation to the first scenario in degrees Celsius. ---, no data; Sept., September; Oct., October; Nov., November]

Scenarios	May	June	July	August	Sept.	Oct.	Nov.
1	15.3 ---	16.7 ---	18.4 ---	17.7 ---	17.6 ---	13.5 ---	7.0 ---
2	15.3 .0	16.8 +.1	19.2 +.8	18.6 +.9	18.0 +.4	13.4 -.1	7.0 .0
3	14.4 -.9	15.7 -1.0	19.8 +1.4	18.7 +1.0	16.5 -1.1	11.3 -2.2	6.5 -.4
4a	16.6 +1.3	18.2 +1.5	20.5 +2.1	19.8 +2.1	18.9 +1.3	13.9 +.4	7.0 +.0
4b	14.3 -1.0	15.6 -1.1	17.5 -.9	16.9 -.8	16.5 -1.1	12.7 -.8	6.8 -.2
5	15.3 .0	16.8 +.1	18.4 .0	17.7 .0	17.6 .0	13.6 +.1	7.0 .0
6	13.6 -1.7	15.0 -1.7	17.3 -1.1	16.8 -.9	16.5 -1.1	12.3 -1.2	5.2 -1.8
7	15.2 -.1	16.6 -.1	18.3 -.1	17.5 -.2	17.3 -.3	13.1 -.4	6.8 -.2
8	15.2 -.1	16.7 .0	19.3 +.9	18.5 +.8	17.7 +.1	12.9 -.6	6.8 -.2
9	15.2 -.1	16.6 -.1	18.3 -.1	17.5 -.2	17.3 -.3	13.0 -.5	6.8 -.2
10	13.4 -1.9	14.7 -2.0	17.1 -1.3	16.5 -1.2	16.1 -1.5	11.8 -1.7	5.0 -2.0

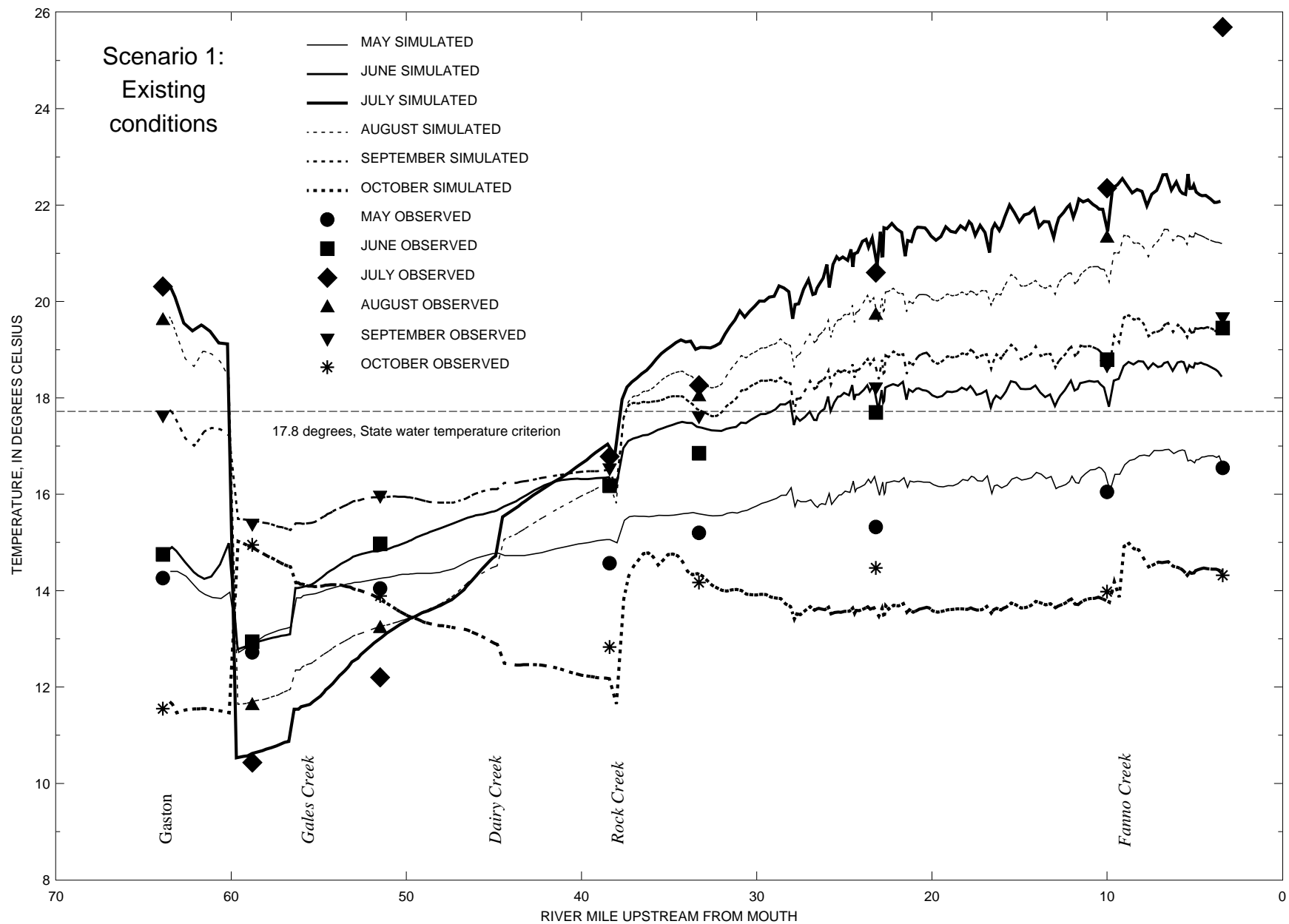

Figure 15. Monthly mean of the 7-day moving average of daily maximum simulated and observed 1994 water temperatures for scenario 1, existing conditions.

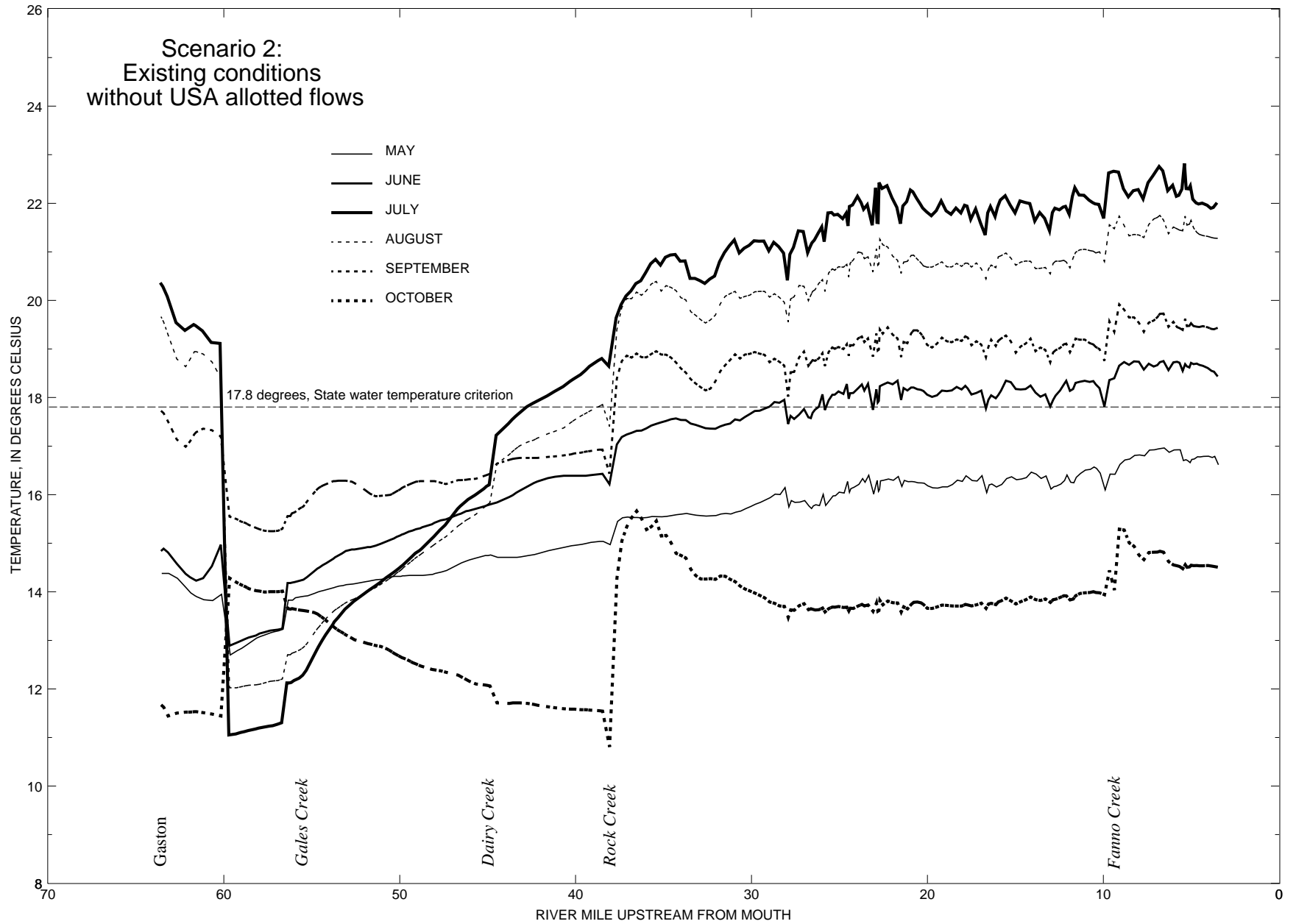

Figure 16. Monthly mean of the 7-day moving average of daily maximum simulated 1994 water temperatures for scenario 2, existing conditions without Unified Sewerage Agency allotted flows. (USA, Unified Sewerage Agency.)

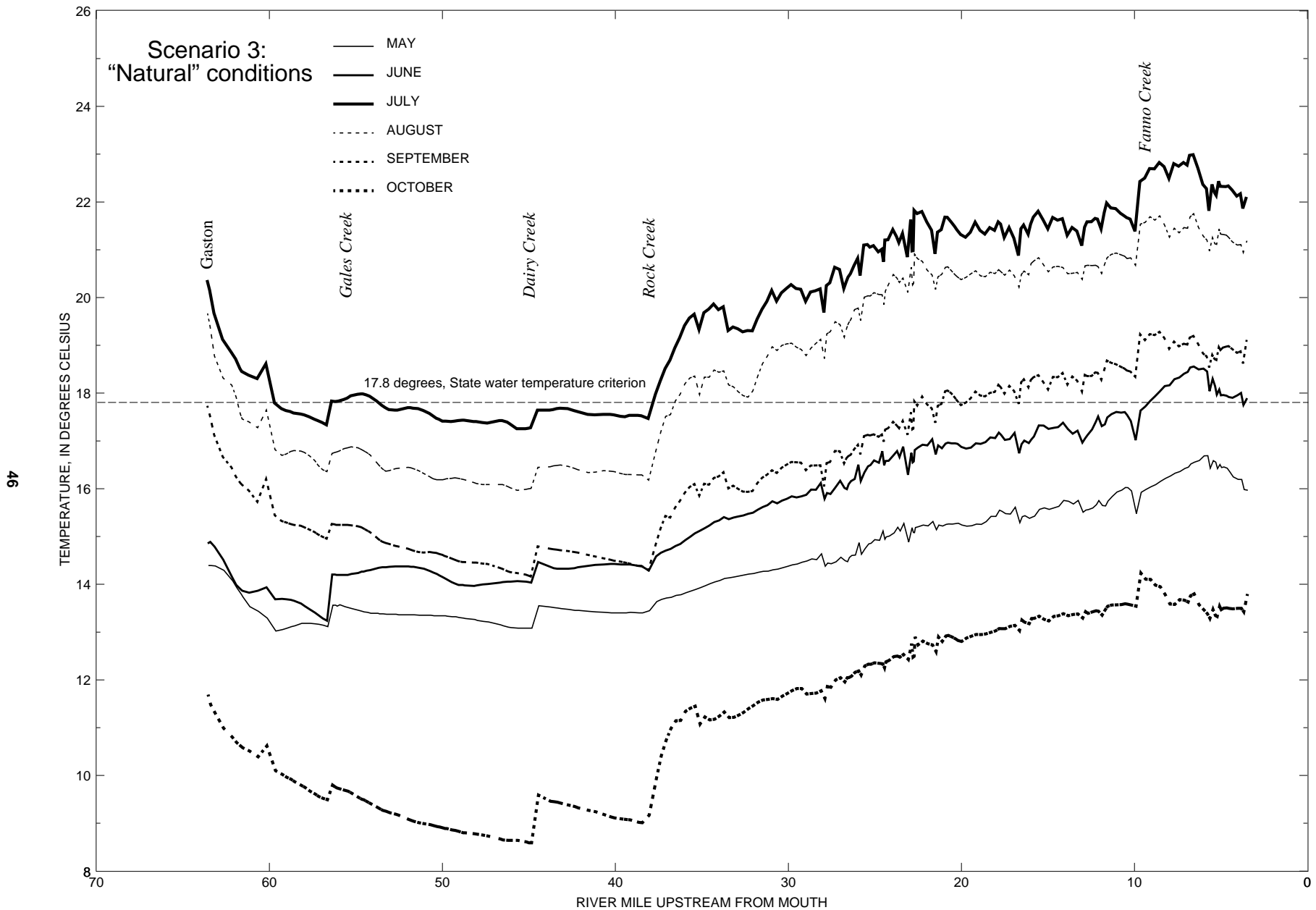

Figure 17. Monthly mean of the 7-day moving average of daily maximum simulated 1994 water temperatures for scenario 3, "natural" conditions.

Figure 17 also shows a temperature decline from Gaston (RM 63.9) to Gales Creek and abrupt temperature rises followed by declines at the confluences of Gales Creek, Dairy Creek, Rock Creek, and Fanno Creek. The simulated temperature increases probably occurred because modern water temperature data had to be used for all the tributary boundaries. If preagricultural-development temperature data had been available for input to the model, the abrupt rises probably would not have occurred. The steep rise near RM 38 is a result of warmer Rock Creek flows and also because it is at the transition zone between the upper and lower stream section models. However, the transition was not smooth because the models have different hydraulic and transport algorithms. For example, the upper stream section model is one-dimensional, whereas the lower stream section model is two-dimensional.

Scenario 4: Extremes in riparian shade conditions—Simulation results for scenarios addressing vegetative shading are shown in figure 18. The models showed a consistent response to shade variation. Changes in shading always caused an inverse change in water temperatures. Except in October (fig. 18), the difference between no shading and current shading was pronounced. It also is interesting to observe that the increased benefit of cooling that occurs between current- and maximum-shading conditions diminishes downstream. This phenomenon is expected because, as the river widens, the difference between current and maximum shading affects a smaller portion of the water surface. In July and August, water temperatures averaged over the entire river reach increase by 2.1°C when all shade is removed. When shading was maximized, there was a 0.9 and 0.8°C decrease for July and August, respectively.

Scenario 5: Existing conditions without the low-head diversion dam at RM 3.4—Simulated removal of the low-head diversion dam had a limited impact on water temperatures in the lower section of the river (fig. 19). Relative to scenario 1, water temperatures slightly decrease (less than 0.5°C) from RM 38.4 to RM 10.0 during the summer, because the travel time above RM 10.0 is slightly less. However, below RM 10.0, simulated water temperatures were slightly warmer (less than 0.5°C) than the corresponding simulated water temperatures in scenario 1. There is less water volume in this reach and the impact of the Durham WWTP effluent would be greater.

Water temperatures averaged over the entire river reach for any given month showed negligible change (less than 0.1°C) relative to those in scenario 1.

Scenario 6: Existing conditions with tributary temperature reduction—A 2°C temperature reduction in the tributaries considerably lowered water temperatures in the main stem above Rood Bridge (RM 38.4) (fig. 20). However, the impact is less pronounced in the lower stream section (below RM 38.4), because the ratio of tributary flow to main-stem flow is much lower in the lower stream section than in the upper stream section. Water temperatures still exceed 17.8°C for the months of June, July, August, and September, but exceedences occur at locations farther downstream than in scenario 1. Between RM 10 and the dam at RM 3.4, the water temperatures were almost as high as they were in scenario 1, existing conditions. Water temperatures averaged over the entire river reach for July and August decrease by 1.1 and 0.9°C, respectively, relative to those under existing conditions, scenario 1.

Scenario 7: Existing conditions without wastewater-treatment plants—In scenario 7, the existing conditions of scenario 1 were simulated except effluent from the WWTPs was not discharged into the river (fig. 21). A plot showing the difference between the monthly mean 7-day moving average of daily maximum simulated 1994 water temperatures for scenario 1 and scenario 7 is shown in figure 22. For the 10-mile reach downstream of the Rock Creek WWTP (RM 38.1), there is a temperature reduction (0.5°C or greater) in most months when the plant is not in operation. However, during the months of July, August, and September, the water temperatures still exceed the 17.8°C criterion. The greatest reduction occurred during October; however, temperatures in that month were already far below 17.8°C, even with the plant operating. For most months, there was less of a temperature reduction downstream of the Durham WWTP (RM 9.3) when the plants were not operating than in the reach below the Rock Creek WWTP. The volume of flow in this reach is significantly greater than the volume of flow below the Rock Creek WWTP. Also, there is less of a temperature differential between the river and the effluent. Under scenario 7, water temperatures averaged over the entire river reach for any given month did not show any significant change relative to those in scenario 1.

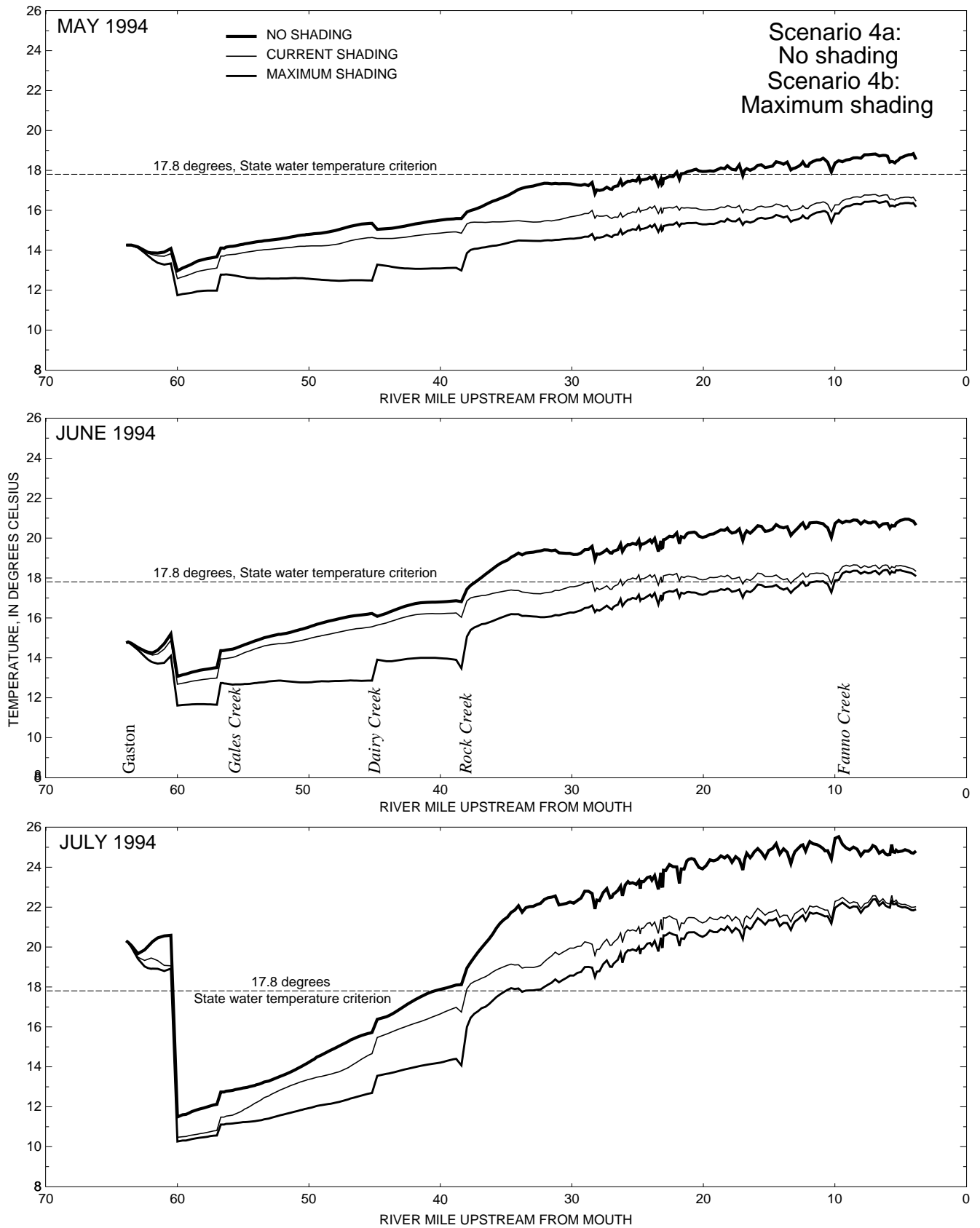

Figure 18. Monthly mean of the 7-day moving average of daily maximum simulated water temperatures for scenario 4, extremes of riparian shade conditions, May through October 1994.

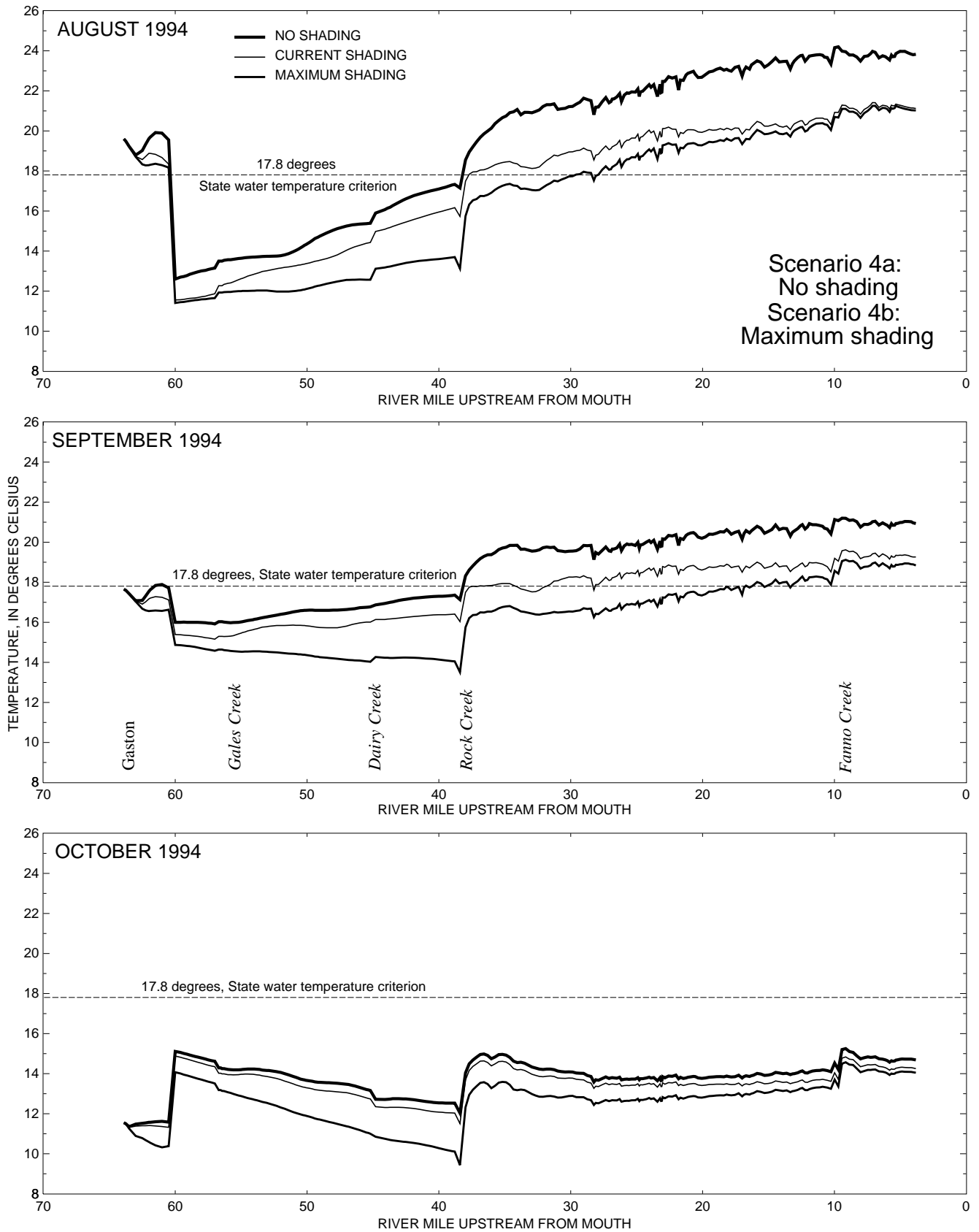

Figure 18. Monthly mean of the 7-day moving average of daily maximum simulated water temperatures for scenario 4, extremes of riparian shade conditions, May through October 1994—Continued.

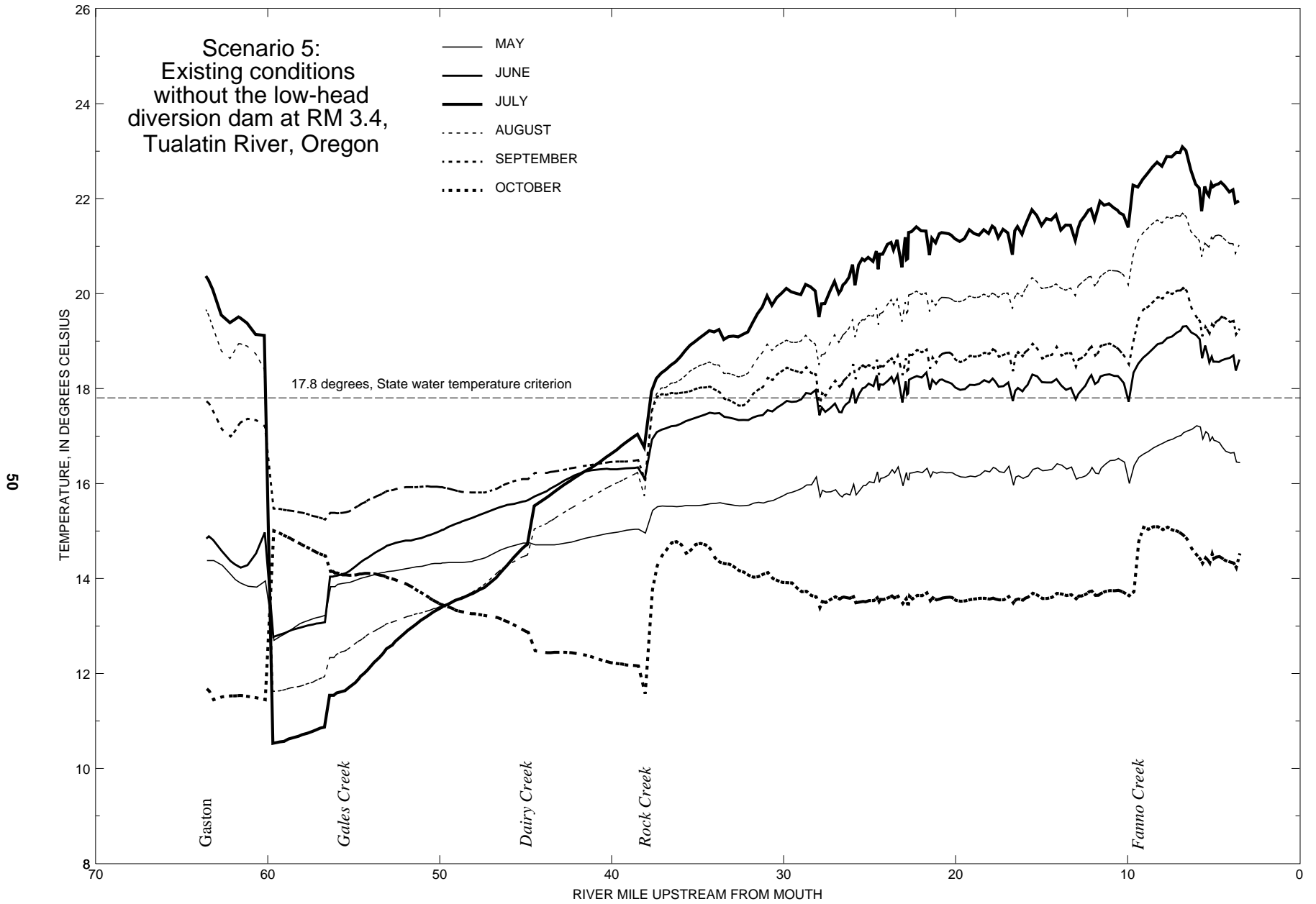

Figure 19. Monthly mean of the 7-day moving average of daily maximum simulated 1994 water temperatures for scenario 5, existing conditions without the low-head diversion dam at river mile 3.4, Tualatin River, Oregon. (RM, river mile.)

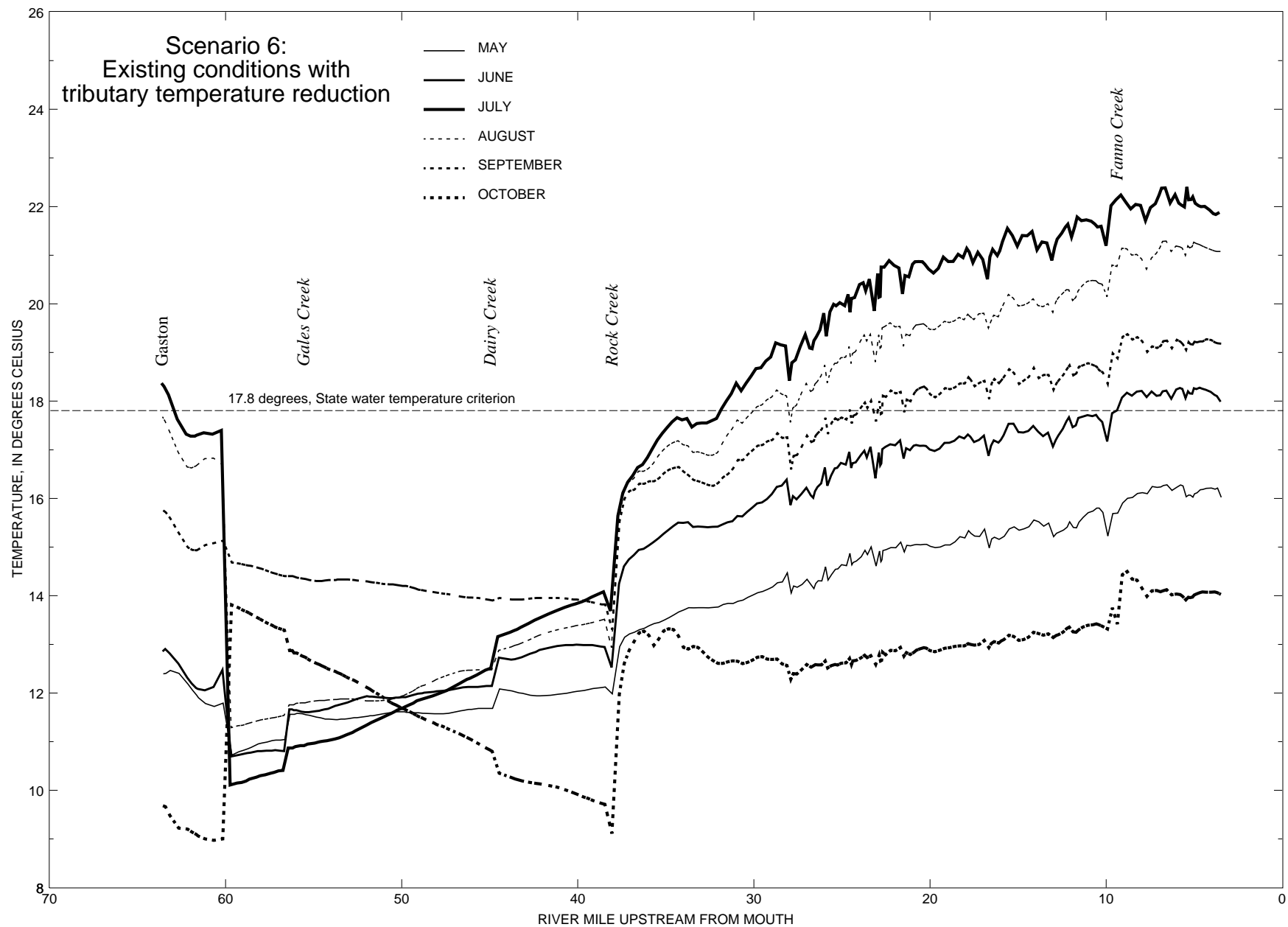

Figure 20. Monthly mean of the 7-day moving average of daily maximum simulated 1994 water temperatures for scenario 6, existing conditions with tributary temperature reduction.

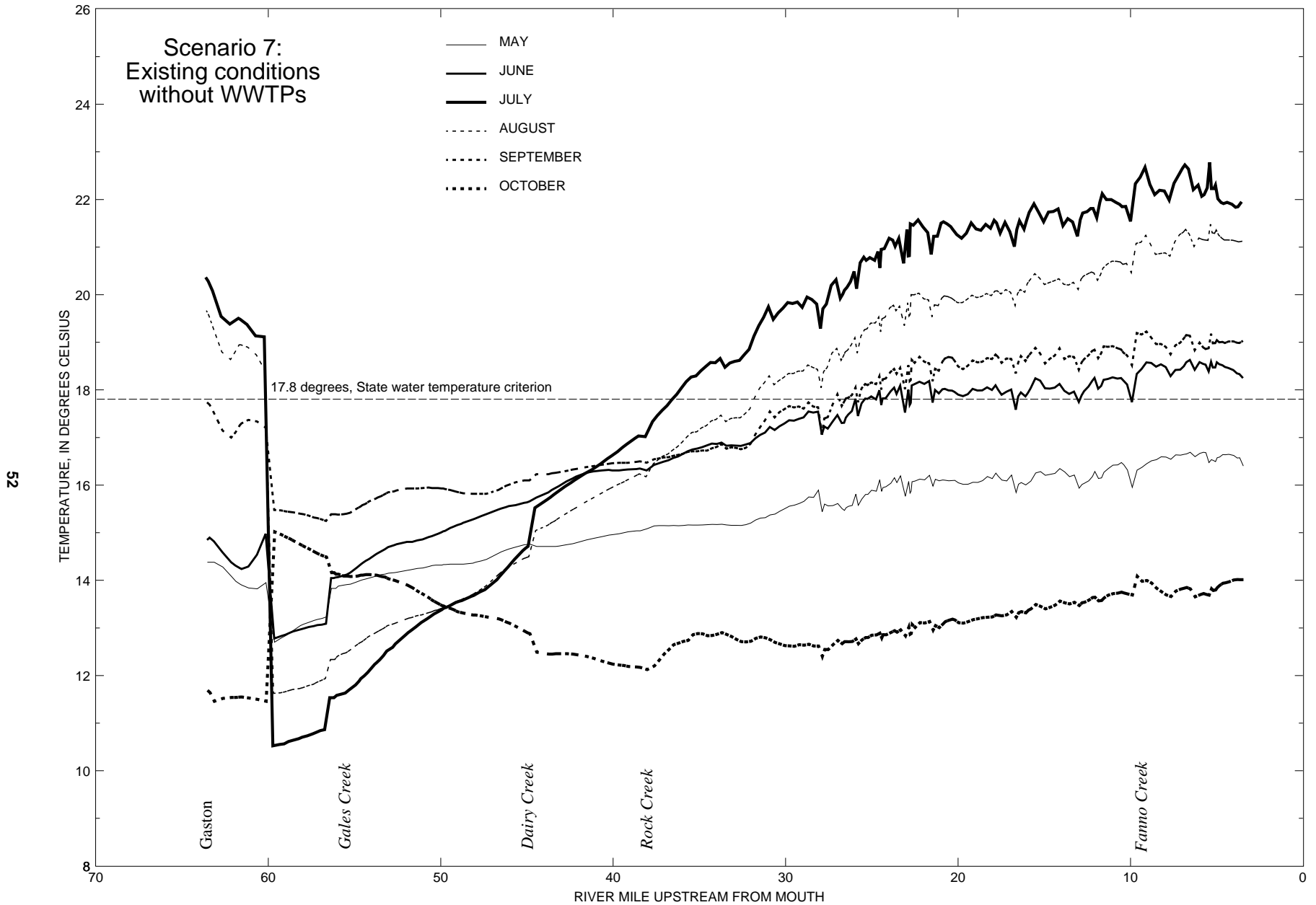

Figure 21. Monthly mean of the 7-day moving average of daily maximum simulated 1994 water temperatures for scenario 7, existing conditions without wastewater-treatment plants. (WWTPs, wastewater-treatment plants.)

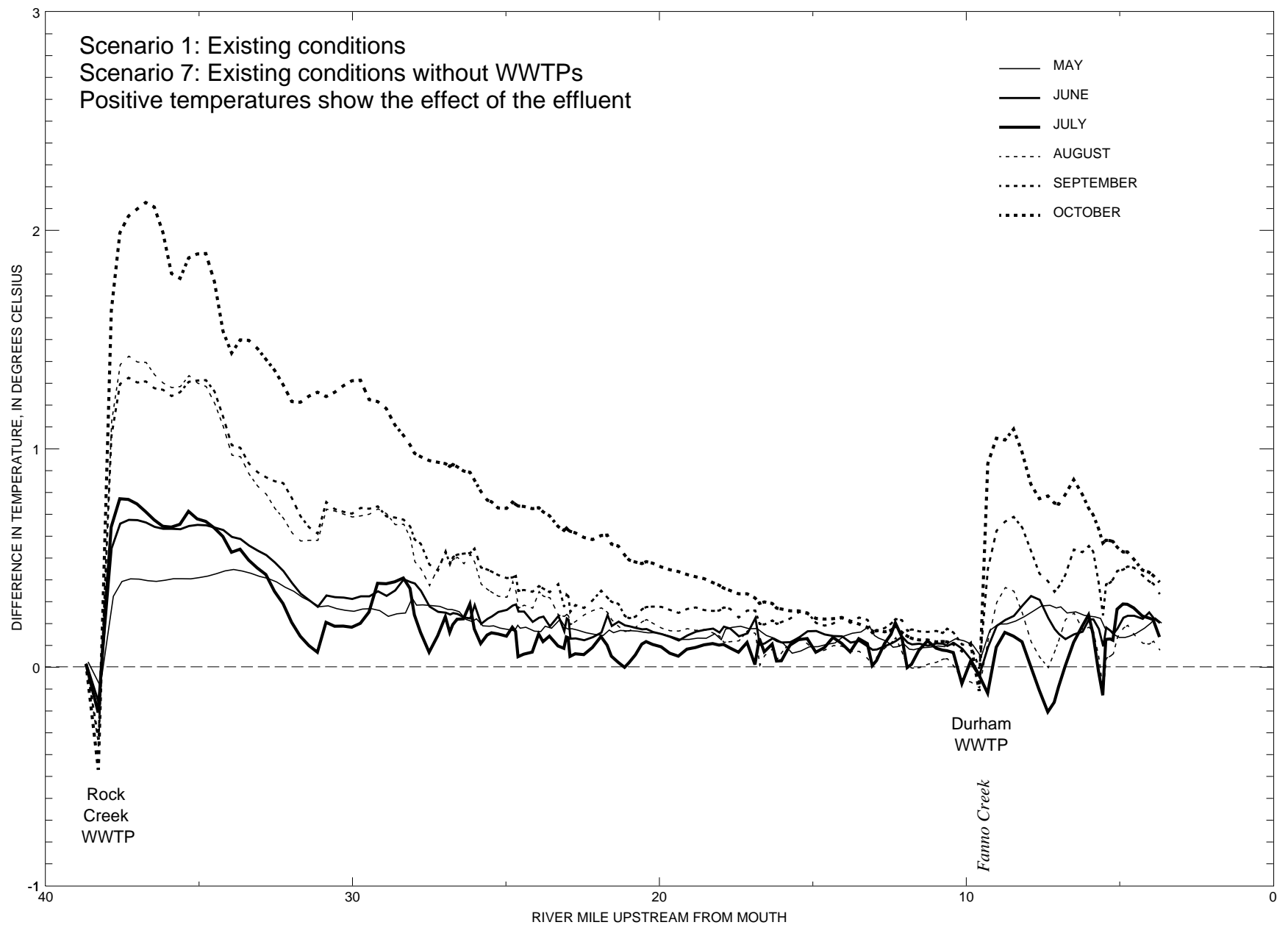

Figure 22. The difference between monthly mean of the 7-day moving average of daily maximum simulated 1994 water temperatures for scenario 1 and scenario 7. (WWTPs, wastewater-treatment plants.)

Scenario 8: Existing conditions without Unified Sewerage Agency allotted flows, lower section withdrawals, and wastewater-treatment plants—

In scenario 8, the existing conditions from scenario 1 were simulated without allotted USA releases from Henry Hagg Lake reservoir, irrigation withdrawals in the lower stream section, diversion flows for the Oswego Canal, and effluent releases from both WWTPs (fig. 23). Under this scenario, some decrease in temperatures downstream of the Rock Creek WWTP occurred. However, at RM 20.0 and RM 10.0, the temperatures were no different from corresponding temperatures in scenario 2, existing conditions without USA allotted flows. Below the Durham WWTP (RM 9.3), temperatures were only slightly reduced. Withdrawals from the lower stream section were not used in this scenario because maintaining a sufficient water level in the lower stream section for operation of the lower stream section model was necessary.

*Scenario 9: Existing conditions without the low-head diversion dam at RM 3.4 and the wastewater-treatment plants—*When the existing conditions of scenario 1 without the low-head diversion dam at RM 3.4 and the WWTPs were simulated, water temperatures decreased relative to scenario 5 for all months between RM 38.4 and RM 20 (fig. 24). However, between RM 20.0 and RM 10.0, there was

no significant difference. Below the Durham WWTP (RM 9.3), temperatures were only slightly reduced.

*Scenario 10: Existing conditions with tributary temperature reduction and without wastewater-treatment plants—*In scenario 10, a 2°C tributary temperature reduction was combined with zero effluent inflows. For some reaches, the results of this scenario were the same as the results of scenario 6. However, with the absence of effluent inflows from the Rock Creek WWTP, water temperatures were generally lower between RM 38.1 and RM 25 for all months (fig. 25). Downstream of the Durham WWTP, water temperatures also decreased for all months. However, the decreases were less pronounced in the months of July and August.

The percentage of days in a given month that the 7-day moving average of the daily maximum water temperature at each segment exceeded the 17.8°C criterion also was computed for each of the 10 management scenarios for each month from May through October. These percentages for each scenario for each month for each stream segment are presented in Appendix H. Monthly percentages for each scenario for the entire study reach are presented in table 10. Monthly percentages for each scenario for selected locations are presented in tables 11 through 17. Plots of percentages based on the 7-month simulation period (May through November) for each scenario are shown in figure 26.

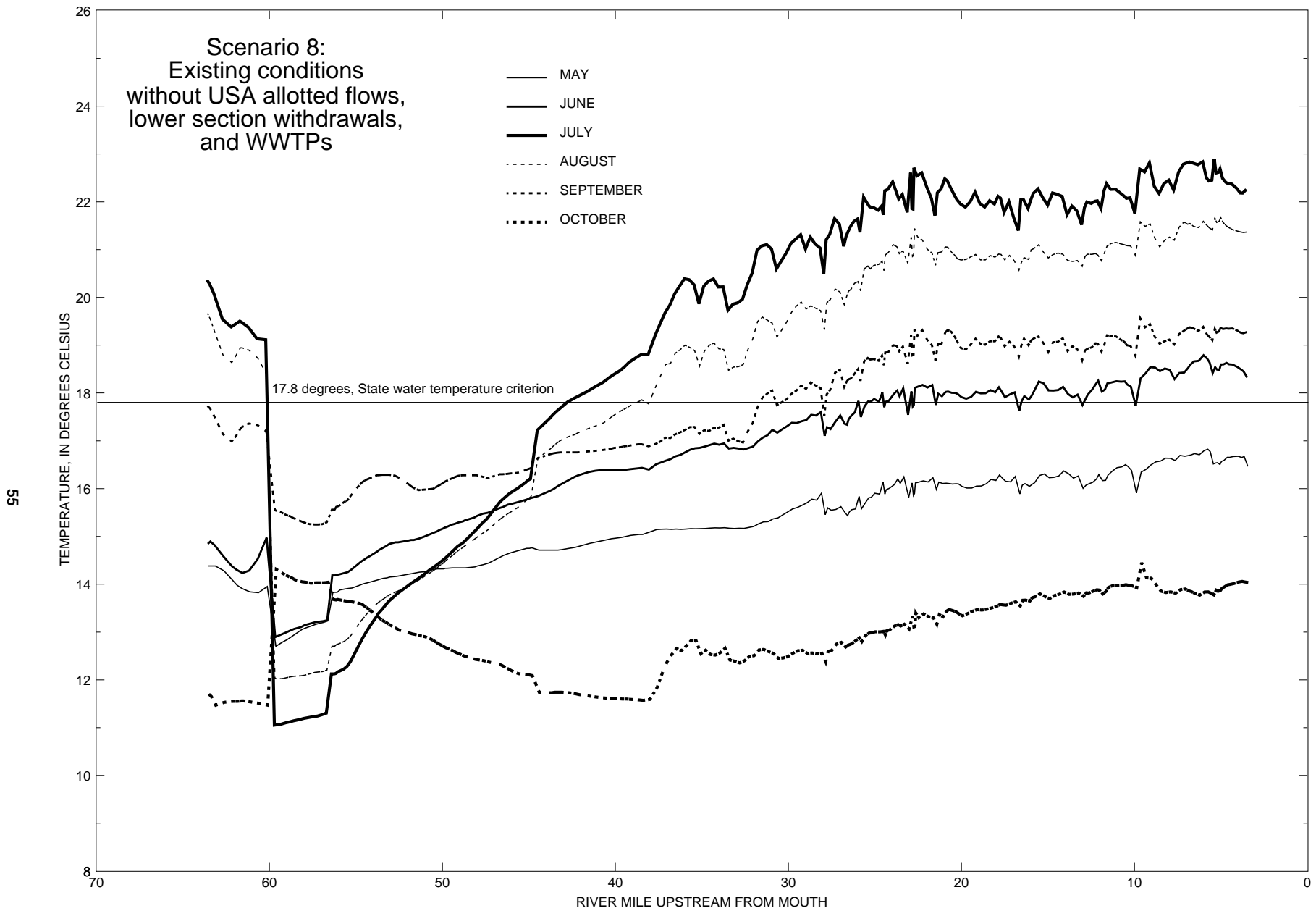

Figure 23. Monthly mean of the 7-day moving average of daily maximum simulated 1994 water temperatures for scenario 8, existing conditions without Unified Sewerage Agency allotted flows, lower stream section withdrawals, and wastewater-treatment plants. (USA, Unified Sewerage Agency; WWTPs, wastewater-treatment plants.)

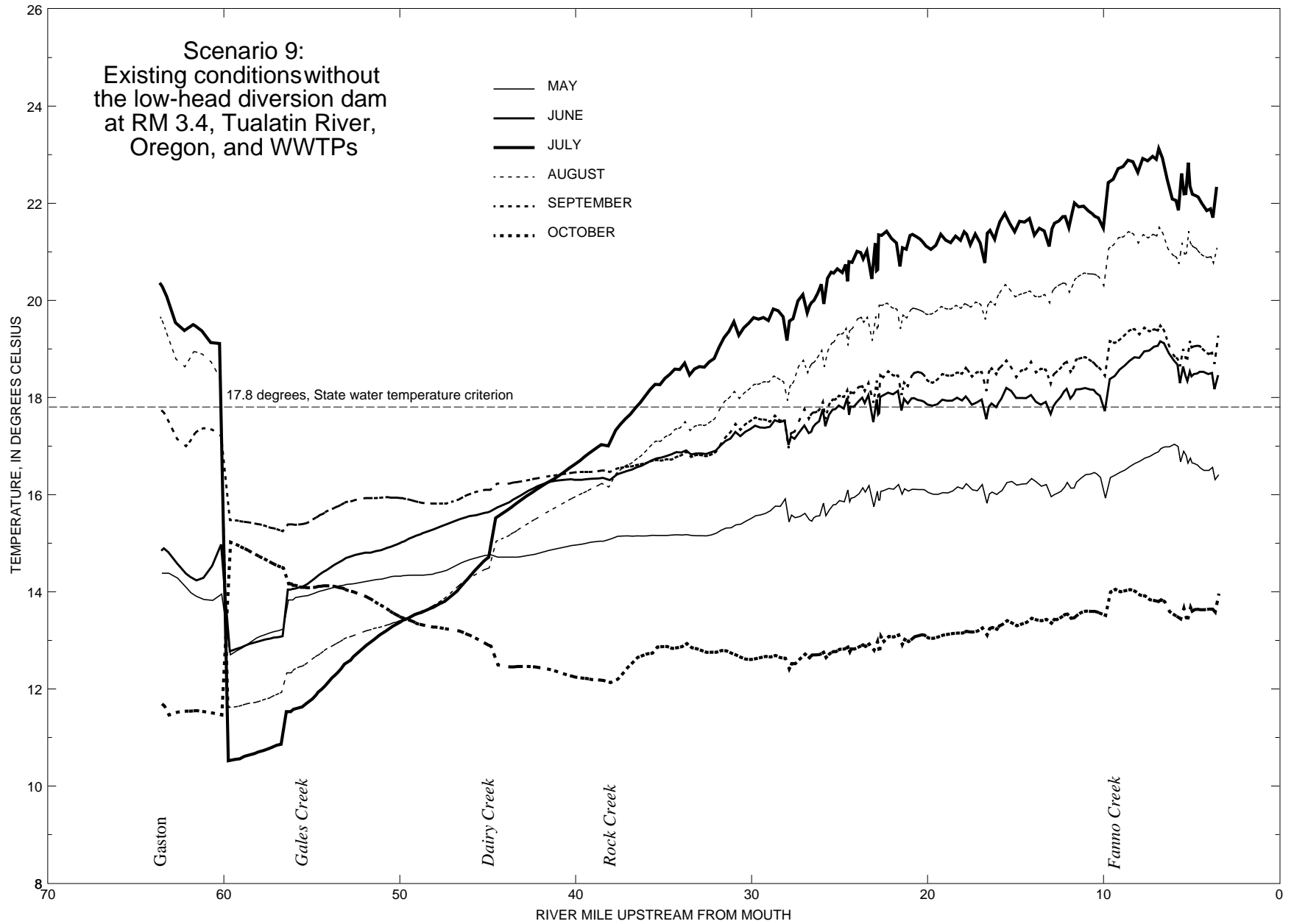

Figure 24. Monthly mean of the 7-day moving average of daily maximum simulated 1994 water temperatures for scenario 9, existing conditions without the low-head diversion dam at river mile 3.4 and the wastewater-treatment plants, Tualatin River, Oregon. (RM, river mile; WWTPs, wastewater-treatment plants.)

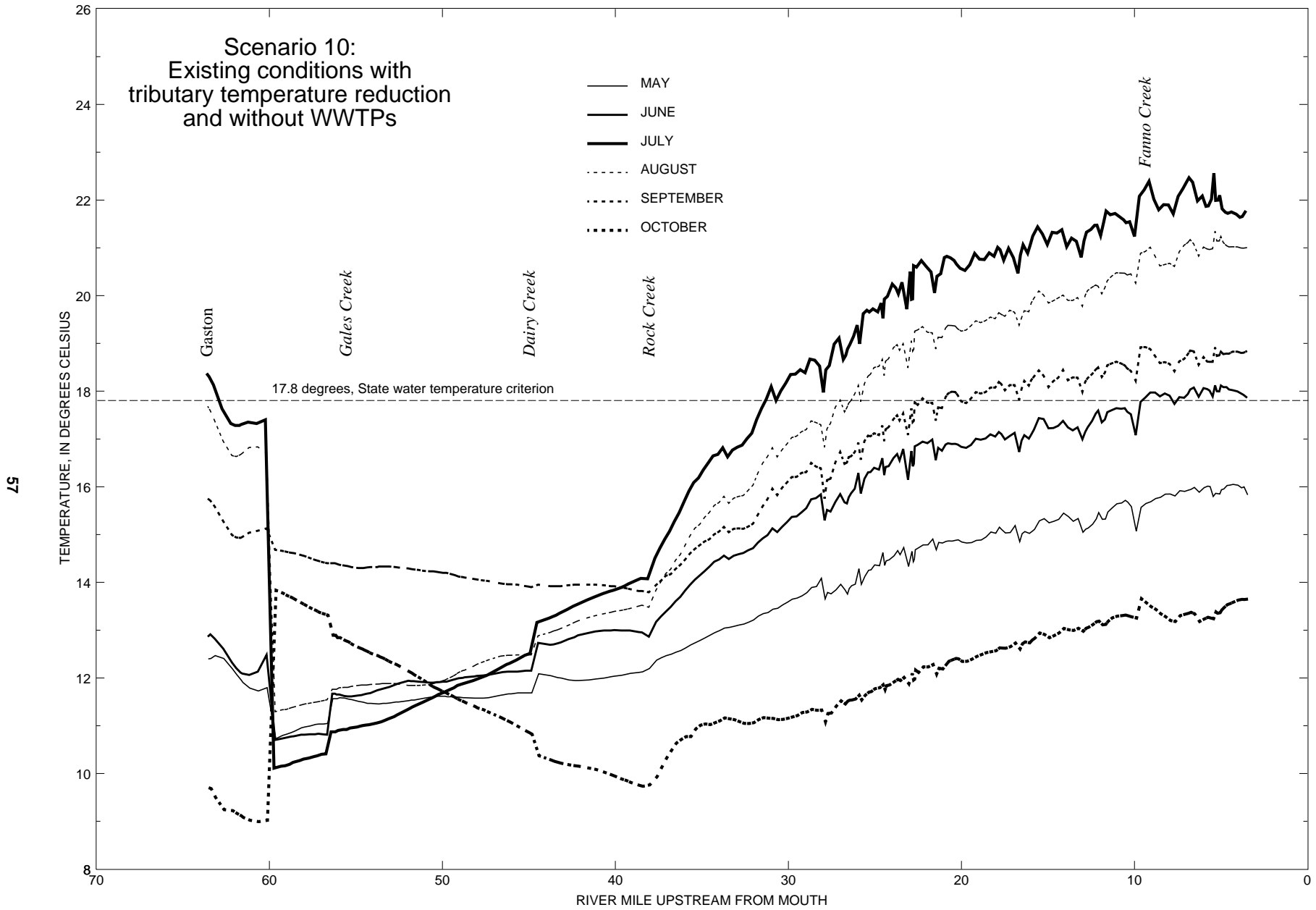

Figure 25. Monthly mean of the 7-day moving average of daily maximum simulated 1994 water temperatures for scenario 10, existing conditions with tributary temperature reduction and without wastewater-treatment plants. (WWTPs, wastewater-treatment plants.)

Table 10. Percentage of time the 7-day moving average of daily maximum simulated 1994 water temperature in the study reach (river mile 63.9 to river mile 3.4) exceeds 17.8 degrees Celsius for each management scenario during each month [Sept., September; Oct., October; Nov., November]

Scenario	May	June	July	August	Sept.	Oct.	Nov.	May–Nov.
1	0.4	29.7	64.1	64.0	49.2	3.1	0	30.1
2	.4	29.9	70.8	68.7	58.0	5.2	0	33.3
3	0	15.3	76.4	61.0	30.0	.9	0	26.2
4a	35.5	58.6	69.2	67.6	67.9	7.5	0	43.8
4b	0	19.0	57.3	52.3	26.8	1.1	0	22.4
5	1.9	30.3	64.2	64.1	48.5	2.8	0	30.3
6	0	15.9	54.7	49.6	34.8	1.8	0	22.4
7	0	25.6	62.0	56.8	41.2	2.2	0	26.8
8	0	26.3	69.5	66.4	50.5	3.1	0	30.8
9	.9	26.1	62.0	56.2	39.7	1.8	0	26.7
10	0	14.3	52.6	44.7	28.4	1.1	0	20.2

Table 11. Percentage of time the 7-day moving average of daily maximum simulated 1994 water temperature near Dilley (river mile 58.8) exceeds 17.8 degrees Celsius for each management scenario during each month [Sept., September; Oct., October; Nov., November]

Scenario	May	June	July	August	Sept.	Oct.	Nov.	May–Nov.
1	0	0	0	0	0	0	0	0
2	0	0	0	0	0	0	0	0
3	0	0	48.4	3.2	0	0	0	7.4
4a	0	0	0	0	0	0	0	0
4b	0	0	0	0	0	0	0	0
5	0	0	0	0	0	0	0	0
6	0	0	0	0	0	0	0	0
7	0	0	0	0	0	0	0	0
8	0	0	0	0	0	0	0	0
9	0	0	0	0	0	0	0	0
10	0	0	0	0	0	0	0	0

Table 12. Percentage of time the 7-day moving average of daily maximum simulated 1994 water temperature at Golf Course Road (river mile 51.5) exceeds 17.8 degrees Celsius for each management scenario during each month [Sept., September; Oct., October; Nov., November]

Scenario	May	June	July	August	Sept.	Oct.	Nov.	May–Nov.
1	0	0	0	0	0	0	0	0
2	0	0	0	0	0	0	0	0
3	0	0	48.4	0	0	0	0	6.9
4a	0	0	0	0	20.0	0	0	2.9
4b	0	0	0	0	0	0	0	0
5	0	0	0	0	0	0	0	0
6	0	0	0	0	0	0	0	0
7	0	0	0	0	0	0	0	0
8	0	0	0	0	0	0	0	0
9	0	0	0	0	0	0	0	0
10	0	0	0	0	0	0	0	0

Table 13. Percentage of time the 7-day moving average of daily maximum simulated 1994 water temperature at Rood Bridge (river mile 38.4) exceeds 17.8 degrees Celsius for each management scenario during each month [Sept., September; Oct., October; Nov., November]

Scenario	May	June	July	August	Sept.	Oct.	Nov.	May–Nov.
1	0	0	6.5	0	0	0	0	0.9
2	0	0	74.2	22.6	0	0	0	13.8
3	0	0	45.2	0	0	0	0	6.5
4a	0	33.3	74.2	19.4	30.0	0	0	22.4
4b	0	0	0	0	0	0	0	0
5	0	0	6.5	0	0	0	0	0.9
6	0	0	0	0	0	0	0	0
7	0	0	9.7	0	3.3	0	0	1.9
8	0	13.3	74.2	38.7	20.0	0	0	20.9
9	0	0	9.7	0	3.3	0	0	1.9
10	0	0	0	0	0	0	0	0

Table 14. Percentage of time the 7-day moving average of daily maximum simulated 1994 water temperature at Farmington (river mile 33.3) exceeds 17.8 degrees Celsius for each management scenario during each month [Sept., September; Oct., October; Nov., November]

Scenario	May	June	July	August	Sept.	Oct.	Nov.	May-Nov.
1	0	36.7	80.6	71	40	0	0	32.6
2	0	36.7	93.5	100	60	0	0	41.5
3	0	0	74.2	64.5	0	0	0	69.4
4a	0	80	100	100	100	6.5	0	55.2
4b	0	0	48.4	9.7	0	0	0	8.3
5	0	36.7	83.9	74.2	43.3	0	0	34
6	0	0	32.3	0	0	0	0	4.6
7	0	33.3	74.2	32.3	20	0	0	22.8
8	0	33.3	83.9	64.5	23.3	0	0	29.3
9	0	33.3	77.4	32.3	23.3	0	0	23.8
10	0	0	25.8	0	0	0	0	3.7

Table 15. Percentage of time the 7-day moving average of daily maximum simulated 1994 water temperature at Scholls Ferry Bridge (river mile 26.9) exceeds 17.8 degrees Celsius for each management scenario during each month [Sept., September; Oct., October; Nov., November]

Scenario	May	June	July	August	Sept.	Oct.	Nov.	May-Nov.
1	0	36.7	100	100	66.7	0	0	43.3
2	0	36.7	100	100	80	3.2	0	45.7
3	0	20	83.9	100	0	0	0	29.1
4a	41.9	76.7	100	100	100	6.5	0	60.7
4b	0	30	80.6	64.5	0	0	0	25
5	0	36.7	100	100	63.3	0	0	42.9
6	0	10	77.4	71	30	0	0	26.9
7	0	36.7	90.3	87.1	46.7	0	0	37.3
8	0	36.7	100	100	66.7	0	0	43.3
9	0	36.7	90.3	83.9	46.7	0	0	36.8
10	0	0	74.2	41.9	6.7	0	0	17.5

Table 16. Percentage of time the 7-day moving average of daily maximum simulated 1994 water temperature at Elsner Road (river mile 16.2) exceeds 17.8 degrees Celsius for each management scenario during each month [Sept., September; Oct., October; Nov., November]

Scenario	May	June	July	August	Sept.	Oct.	Nov.	May-Nov.
1	0	43.3	100	100	83.3	6.5	0	47.6
2	0	43.3	100	100	100	9.7	0	50.4
3	0	30	100	100	73.3	3.2	0	43.8
4a	61.3	100	100	100	100	12.9	0	67.7
4b	0	33.3	100	100	60	0	0	41.9
5	0	43.3	100	100	80	6.5	0	47.1
6	0	33.3	100	100	70	3.2	0	43.8
7	0	40	100	100	80	6.5	0	46.6
8	0	40	100	100	100	9.7	0	50
9	0	36.7	100	100	76.7	3.2	0	45.2
10	0	30	100	100	70	3.2	0	43.3

Table 17. Percentage of time the 7-day moving average of daily maximum simulated 1994 water temperature at Stafford Road (river mile 5.5) exceeds 17.8 degrees Celsius for each management scenario during each month [Sept., September; Oct., October; Nov., November]

Scenario	May	June	July	August	Sept.	Oct.	Nov.	May-Nov.
1	0	70	100	100	83.3	9.7	0	51.9
2	0	70	100	100	100	12.9	0	54.7
3	0	40	100	100	73.3	3.2	0	45.2
4a	77.4	100	100	100	100	19.4	0	71
4b	0	56.7	100	100	60	6.5	0	46.2
5	22.6	73.3	100	100	80	9.7	0	55.1
6	0	40	100	100	70	9.7	0	45.7
7	0	56.7	100	100	80	6.5	0	49
8	0	56.7	100	100	100	6.5	0	51.9
9	0	60	100	100	76.7	6.5	0	49
10	0	40	100	100	70	6.5	0	45.2

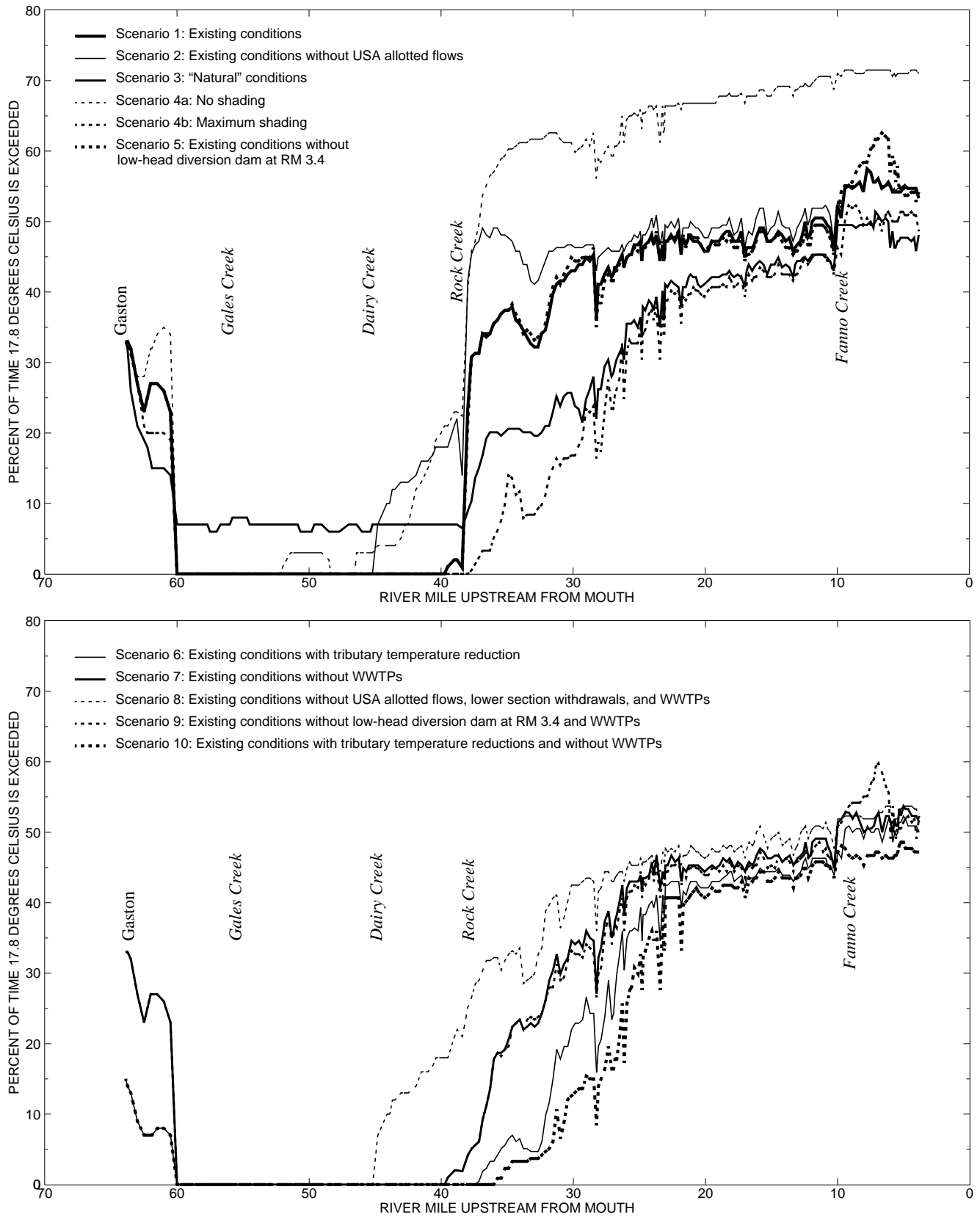

Figure 26. The percentage of time the 7-day moving average of daily maximum simulated water temperature exceeds 17.8 degrees Celsius from May 1 through November 30, 1994, for scenarios 1 through 10. (USA, Unified Sewerage Agency; RM, river mile; WWTPs, wastewater-treatment plants.)

SUMMARY AND CONCLUSIONS

In Oregon, the critical water temperature survival threshold for many fish and aquatic organisms is reached or surpassed during low-flow periods from July to October. In an effort to improve the overall health of aquatic ecosystems, the Oregon Department of Environmental Quality has adopted a water temperature standard which states that the 7-day moving average of daily maximum water temperature shall not exceed 17.8°C (degrees Celsius) for waterways like the Tualatin River. Under the standard, a point discharge is not permitted to raise the temperature of the water body above this level. In the Tualatin River, water temperatures typically surpass this threshold during the low-flow summer and fall months, particularly in the reservoir-like section (river mile [RM] 29.7 to RM 3.4).

This study was done in cooperation with the Unified Sewerage Agency of Washington County, Oregon, and had the following objectives:

- (1) To quantify the temporal and spatial patterns of water temperature in the main stem of the Tualatin River and the mouths of its major tributaries.
- (2) To determine the relation of water temperature in the Tualatin River and its major tributaries to climatic conditions, seasonal and diel variations, and human-caused factors.
- (3) To assess the impact of various flow-management practices on stream temperature during the low-flow season (July through October).

The approach used to meet the study objectives included field data collection and computer modeling. Half-hourly and hourly instantaneous temperature measurements were recorded at 13 monitoring sites throughout a 60-mile reach of the river from May through November of 1994. Also, four separate synoptic temperature surveys were conducted in the upstream and downstream vicinities of the Rock Creek and Durham wastewater-treatment-plant outfalls during the period from July through October 1994.

The observed temperature and streamflow data were used to calibrate dynamic flow (DAFLOW), transport (BLTM), and flow-transport (CE-QUAL-W2) models. The DAFLOW and BLTM models are

one-dimensional; they were applied to the section of the river upstream of Rood Bridge near Hillsboro (RM 63.9 to RM 38.4). The CE-QUAL-W2 model is a laterally averaged two-dimensional model; it was applied to the lower section of the river (RM 38.4 to RM 3.4). A variety of management practices were assessed by conducting model simulations of the following scenarios:

- (1) Existing conditions using 1994 observed meteorologic, flow, shade, and hydraulic data.
- (2) Existing conditions without Unified Sewerage Agency allotted flow releases from Henry Hagg Lake reservoir.
- (3) "Natural" conditions with maximum shading and without any reservoirs, effluent discharge, withdrawals, diversions, and flow augmentation from outside the basin.
- (4) Extremes of riparian shade conditions.
- (5) Existing conditions without the low-head diversion dam at RM 3.4.
- (6) Existing conditions with cooler tributary inflows.
- (7) Existing conditions without wastewater-treatment-plant effluent.
- (8) Existing conditions without Unified Sewerage Agency allotted flow releases from Henry Hagg Lake reservoir, lower section withdrawals, and wastewater-treatment-plant effluent.
- (9) Existing conditions without the low-head diversion dam at RM 3.4 and without wastewater-treatment-plant effluent.
- (10) Existing conditions with cooler tributary inflows and without wastewater-treatment-plant effluent.

Findings from the scenario simulations, based on 1994 water temperature data for simulation input, included the following:

- (1) Withholding Unified Sewerage Agency allotted flow releases from Henry Hagg

Lake reservoir resulted in warmer water in the main stem. Water temperatures, averaged over the entire river reach from RM 63.9 to RM 3.4, increased 0.8 and 0.9°C in July and August, respectively.

- (2) Under “natural” conditions, the temperature of the river would still exceed the State of Oregon maximum water-temperature standard of 17.8°C at many locations downstream of Rood Bridge (RM 38.4) during the low-flow season. Water temperatures averaged over the entire river reach from RM 63.9 to RM 3.4 for July and August increased by 1.4 and 1.0°C, respectively. However, these temperatures decreased in other months.
- (3) Removal of the low-head diversion dam at RM 3.4 would slightly decrease (less than 0.5°C) water temperatures from RM 38.4 to RM 10.0 during the low-flow period. However, water temperatures would slightly increase (less than 0.5°C) below RM 10.0. Water temperatures averaged over the entire river reach, from RM 63.9 to RM 3.4, for any given month showed negligible change (less than 0.1°C) in relation to existing conditions.
- (4) Current operation of the wastewater-treatment plants increases the water temperatures for reaches downstream of the plants under low-flow conditions. However, with or without the operation of the wastewater-treatment plants, water temperatures can still exceed the 17.8°C criterion during the months of July, August, and September. For most low-flow period months in 1994, Rock Creek wastewater-treatment-plant effluent increased water temperatures by 0.5°C or greater for the 10-mile reach downstream of its outfall (RM 38.1). Downstream of that 10-mile reach, the effect of ambient environmental conditions becomes greater than the effect of the Rock Creek wastewater-treatment-plant effluent. At RM 10, the impact of the Durham wastewater-treatment-plant effluent below its outfall was less than the impact of the Rock Creek wastewater-

treatment-plant effluent at its outfall. In the reach below Durham wastewater-treatment plant, there is a greater volume of flow and a smaller temperature differential between the effluent and the receiving water. For most low-flow period months in 1994, Durham wastewater-treatment-plant effluent increased water temperatures by less than 0.5°C in the downstream reach between the plant and the low-head diversion dam at RM 3.4. Water temperatures averaged over the entire river reach from RM 63.9 to RM 3.4 for any given month increased by less than 0.5°C with operation of the plants.

- (5) Water temperatures are significantly affected by riparian shade variations along both the tributaries and the main stem. For both July and August, water temperatures averaged over the entire river reach from RM 63.9 to RM 3.4 increased by 2.1°C compared with existing conditions when all shade was removed. However, when shading was maximized, water temperatures averaged over the entire river reach decreased by 0.9 and 0.8°C compared with existing conditions for July and August, respectively. Most of the decrease in temperatures occurs between RM 60 and about RM 20. Downstream towards the low-head diversion dam at RM 3.4, the impact of increased shading becomes less apparent because of an increase in the stream width and the volume of flow.

Future studies and analyses can be made using the models developed in this study to evaluate the effectiveness of other management scenarios. However, the results of these 10 scenarios indicate that a combination of increasing riparian shading (between RM 60 and RM 20) and some effluent temperature reduction at the Rock Creek wastewater-treatment plant could be the most effective and feasible management strategy for reducing water temperatures in the upper and middle sections of the river. None of the management scenarios showed an effective approach for lowering temperatures in the lower river section (below RM 20). Removal of the low-head diversion dam at RM 3.4 provided only minimal temperature reductions.

REFERENCES CITED

- Bartholow, J.M., 1989, Stream temperature investigations—Field and analytic methods: U.S. Fish and Wildlife Service, Instream Flow and Information Paper No. 13, 139 p.
- Brown, G.W., 1969, Predicting temperatures of small streams: *Water Resources Research*, v. 5, no. 1, pp. 68–75.
- Cass, P.L., and Miner, J.R., 1993, The historical Tualatin River Basin: Oregon Water Resources Research Institute, Tualatin River Basin Water Resources Management Report Number 7, 59 p.
- Cole, T.M., and Buchak, E.M., 1995, CE-QUAL-W2—A two-dimensional, laterally averaged, hydrodynamic and water quality model, version 2.0-users manual, U.S. Army Corps of Engineers, Waterways Experiment Station, Instruction Report EL-95-1, 352 p.
- Doyle, M.C., and Caldwell, J.M., 1996, Water-quality, streamflow and meteorological data for the Tualatin River Basin, Oregon, 1991–93: U.S. Geological Survey Open-File Report 96–173, 49 p.
- Edinger, J.E., and Buchak, E.M., 1975, A hydrodynamic, two-dimensional reservoir model—The computational basis: Cincinnati, Ohio, U.S. Army Corps of Engineers, 94 p.
- Hart, D.H., and Newcomb, R.C., 1965, Geology and ground water of the Tualatin Valley, Oregon: U.S. Geological Survey Water-Supply Paper 1697, 172 p.
- Jobson, H.E., 1981, Temperature and solute-transport simulation in streamflow using a Lagrangian reference frame: U.S. Geological Survey Water-Resources Investigations Report 81–2, 165 p.
- Jobson, H.E., 1989, Users manual for an open-channel streamflow model based on the Diffusion Analogy: U.S. Geological Survey Water-Resources Investigations Report 89–4133, 73 p.
- Jobson, H.E., and Keefer, T.N., 1979, Modeling highly transient flow, mass, and heat transport in the Chattahoochee River near Atlanta, Georgia: U.S. Geological Survey Professional Paper 1136, 41 p.
- Jobson, H.E., and Schoellhamer, D.H., 1987, Users manual for a branched Lagrangian transport model: U.S. Geological Survey Water-Resources Investigations Report 87–4163, 73 p.
- Kelly, V.J., 1996, Dissolved oxygen in the Tualatin River, Oregon, during winter flow conditions, 1991 and 1992: U.S. Geological Survey Open-File Report 95–451, 74 p.
- Laenen, Antonius, and Risley, J.C., 1997, Precipitation-runoff and streamflow-routing models for the Willamette River Basin, Oregon: U.S. Geological Survey Water-Resources Investigations Report 95–4284.
- Lee, K.K., 1995, Stream velocity and dispersion characteristics determined by dye-tracer studies on selected stream reaches in the Willamette River Basin, Oregon: U.S. Geological Survey Water-Resources Investigations Report 95–4078, 39 p.
- Mullane, N., Sturdevant, D., and Baumgartner, R., 1995, 1992–1994 Water quality standards review—Temperature final issue paper: Portland, Oregon, Oregon Department of Environmental Quality, Standards and Assessment Section, 114 p.
- Rantz, S.E., and others, 1982, Measurement and computation of streamflow—Volume 1, Measurement of stage and discharge; Volume 2, Computation of discharge: U.S. Geological Survey Water-Supply Paper 2175, 631 p.
- Risley, J.C., and Doyle, M.C., 1997, Water-temperature, specific-conductance, and meteorological data for the Tualatin River Basin, Oregon, 1994–95: U.S. Geological Survey Open-File Report 96–315, 124 p.
- Theurer, F.D., Voos, K.A., and Miller, W.J., 1984, Instream water temperature model—Instream flow information paper 16: U.S. Fish and Wildlife Service, FWS/OBS-84/15 [variously paged].
- U.S. Army Corps of Engineers, 1953, Review of survey report on Tualatin River, Oregon—Appendix C—Public Hearings: Prepared by Portland District, U.S. Army Corps of Engineers, December 31, 1953 [variously paged].

APPENDIX A

RIPARIAN SHADE PARAMETERS

Table A1. Riparian shade parameters used for the DAFLOW/BLTM modeling simulations in the upper reach of the Tualatin River from RM 63.9 to RM 38.4

Average vegetation height (Vh): 60 feet
 Average vegetation offset (Vo): 10 feet
 Crown width (Vc): 50 feet
 Bank height (Bh): 15 feet (RM 38-46) 10 feet (>RM 46)

Vegetation code:
 0 = no vegetation
 1 = single row of vegetation (50 percent crown closure)
 2 = single row of vegetation (100 percent crown closure)
 3 = thick double row of vegetation
 4 = completely wooded areas

```

-----
DAFLOW   Left bank  Right bank  Segment  Segment
BLTM     vegetation  vegetation  azimuth  width
grid     code       code       (degrees) (feet)
-----
    
```

Main stem from RM 63.9 to RM 38.4

1	1	1	280	20
2	1	1	220	20
3	1	1	270	25
4	1	1	275	25
5	1	1	250	30
6	1	1	290	30
7	2	2	230	45
8	2	2	205	45
9	2	2	205	45
10	2	2	200	45
11	3	1	180	45
12	4	4	185	45
13	1	1	170	45
14	2	1	190	45
15	2	4	320	45
16	2	2	230	43
17	4	4	245	43
18	4	3	150	43
19	2	2	180	43
20	2	2	245	43
21	2	2	185	43
22	1	2	250	43
23	2	2	300	43
24	2	1	220	54
25	4	1	15	54
26	4	1	230	54
27	2	1	230	54
28	1	2	310	54
29	1	1	280	54
30	1	1	190	50
31	1	2	260	50
32	2	3	15	50
33	2	2	305	50

Table A1. Riparian shade parameters used for the DAFLOW/BLTM modeling simulations in the upper reach of the Tualatin River from RM 63.9 to RM 38.4—Continued

DAFLOW BLTM grid	Left bank vegetation code	Right bank vegetation code	Segment azimuth (degrees)	Segment width (feet)
Main stem from RM 63.9 to RM 38.4—Continued				
34	4	2	10	50
35	4	1	280	50
36	4	2	180	50
37	2	4	320	50
38	1	2	230	50
39	2	3	190	50
40	2	3	280	50
41	3	3	340	50
42	2	2	270	50
43	3	3	320	50
44	2	2	220	50
45	2	2	185	50
46	2	1	330	55
47	2	4	210	55
48	2	4	340	55
49	2	4	240	55
50	2	4	360	55
51	2	2	225	55
52	2	2	350	55
53	2	4	250	55
54	3	4	25	55
55	4	4	280	55
56	4	4	235	55
57	2	3	320	55
58	3	4	230	55
59	4	2	20	55
60	4	2	280	55
61	3	2	330	55
62	4	4	30	55
63	4	1	285	55
64	4	1	245	55
65	4	1	325	55
66	2	2	205	55
67	3	2	225	55
68	1	1	275	55
69	2	2	215	55
70	2	3	300	55
71	1	4	215	55
72	3	2	295	60
73	3	2	180	60
74	3	2	310	60
75	3	2	230	60
76	2	3	20	60
77	1	4	330	60
78	2	4	65	60

Table A1. Riparian shade parameters used for the DAFLOW/BLTM modeling simulations in the upper reach of the Tualatin River from RM 63.9 to RM 38.4—Continued

DAFLOW BLTM grid	Left bank vegetation code	Right bank vegetation code	Segment azimuth (degrees)	Segment width (feet)
Main stem from RM 63.9 to RM 38.4—Continued				
79	1	4	360	60
80	1	3	295	60
81	2	3	310	60
82	2	2	300	60
83	2	2	300	60
84	2	3	160	60
85	2	2	270	60
86	2	2	90	60
87	2	4	195	60
88	2	4	180	60
89	4	2	245	60
Scoggins Creek from boundary to confluence				
s1	0	0	350	17
s2	0	1	315	17
s3	1	1	265	20
s4	1	1	355	20
s5	1	2	280	20
s7	2	4	270	20
s7	2	4	230	20
s8	1	2	300	30
s9	2	1	265	36
s10	1	1	290	36
s11	4	4	240	40
Gales Creek from boundary to confluence				
g1	3	2	330	36
g2	2	1	240	36
g3	2	1	350	36
g4	1	4	310	38
g5	1	4	55	38
g6	2	4	345	38
g7	1	2	235	40
g8	1	1	305	40
g9	4	2	305	40
Dairy Creek from boundary to confluence				
d1	3	4	350	35
d2	3	3	340	35
d3	2	2	320	35
d4	2	2	290	35
d5	4	2	320	35

Table A2 Riparian shade parameters used for the CE-QUAL-W2 modeling simulations in the lower reach of the Tualatin River from RM 38.4 to RM 3.4

Average vegetation height (Vh): 100 feet

Average vegetation offset (Vo): 15 feet

Crown width (Vc): 50 feet

Bank height (Bh): 15 feet

Vegetation code:

0 = no vegetation

1 = single row of vegetation (50 percent crown closure)

2 = single row of vegetation (100 percent crown closure)

3 = thick double row of vegetation

4 = completely wooded areas

CEQUALW2 model segment	Left bank vegetation code	Right bank vegetation code	Segment azimuth (degrees)	Segment width (feet)
2	4	2	260	33
3	3	1	290	33
4	2	1	20	33
5	3	2	290	33
6	4	0	70	33
7	4	0	350	36
8	4	1	210	36
9	2	1	330	36
10	3	1	350	39
11	2	2	340	39
12	2	1	20	39
13	2	1	140	42
14	2	1	60	42
15	3	3	0	42
16	3	3	350	45
17	2	2	20	45
18	2	4	10	45
19	3	2	35	48
20	2	2	35	51
21	2	2	30	51
22	2	2	0	51
23	2	2	340	51
24	2	2	70	51
25	2	4	320	51
26	3	4	210	51
27	2	4	280	51
28	2	4	350	51
29	2	2	320	51
30	2	2	320	54
31	2	2	320	54
32	2	2	350	60
33	3	2	70	60
34	2	1	20	67
35	3	4	300	67
36	4	2	290	67

Table A2 Riparian shade parameters used for the CE-QUAL-W2 modeling simulations in the lower reach of the Tualatin River from RM 38.4 to RM 3.4—Continued

CEQUALW2 model segment	Left bank vegetation code	Right bank vegetation code	Segment azimuth (degrees)	Segment width (feet)
37	3	3	290	67
38	3	3	270	67
39	4	4	270	67
40	4	3	120	67
41	3	3	180	67
42	3	3	230	67
43	4	4	290	76
44	4	4	290	76
45	3	3	290	85
46	3	3	290	85
47	3	3	310	85
48	2	3	290	85
49	4	4	290	85
50	3	3	220	85
51	3	2	280	85
52	3	2	280	85
53	3	2	310	85
54	2	2	340	85
55	1	1	320	85
56	3	4	320	85
57	2	4	320	85
58	3	2	90	85
59	3	3	90	85
60	3	2	10	85
61	4	3	10	85
62	3	4	340	85
63	3	2	270	85
64	4	4	240	85
65	4	4	240	140
66	4	4	240	140
67	4	3	240	85
68	4	3	90	85
69	4	4	225	85
70	3	2	260	85
71	3	2	350	85
72	3	2	235	85
73	3	4	235	85
74	3	3	235	85
75	2	3	220	85
76	2	3	220	85
77	3	3	220	85
78	3	3	250	85
79	3	4	250	85
80	3	3	270	85
81	4	2	0	85
82	2	2	315	85
83	2	4	280	85

Table A2 Riparian shade parameters used for the CE-QUAL-W2 modeling simulations in the lower reach of the Tualatin River from RM 38.4 to RM 3.4—Continued

CEQUALW2 model segment	Left bank vegetation code	Right bank vegetation code	Segment azimuth (degrees)	Segment width (feet)
84	3	4	30	91
85	2	4	40	97
86	2	4	70	97
87	3	3	320	97
88	3	3	270	97
89	2	2	270	97
90	3	4	10	97
91	4	4	100	97
92	4	4	20	97
93	3	3	300	97
94	3	3	300	97
95	2	2	220	97
96	3	3	275	97
97	3	3	275	97
98	3	3	260	97
99	3	3	270	97
100	3	3	280	97
101	2	3	300	97
102	3	3	190	97
103	2	4	110	97
104	3	3	180	97
105	4	4	60	97
106	4	4	210	97
107	4	4	270	97
108	4	4	280	106
109	4	4	290	106
110	4	4	290	106
111	3	4	320	106
112	3	4	290	106
113	4	3	290	106
114	4	3	270	106
115	3	4	200	106
116	2	3	200	106
117	2	2	250	106
118	2	2	240	106
119	4	4	250	106
120	4	4	260	106
121	4	4	260	106
122	3	3	275	109
123	2	4	330	121
124	4	3	260	121
125	3	3	315	121
126	3	3	280	121
127	3	3	345	121
128	3	2	315	121
129	2	2	280	121
130	3	3	240	121

Table A2 Riparian shade parameters used for the CE-QUAL-W2 modeling simulations in the lower reach of the Tualatin River from RM 38.4 to RM 3.4—Continued

CEQUALW2 model segment	Left bank vegetation code	Right bank vegetation code	Segment azimuth (degrees)	Segment width (feet)
131	3	4	290	121
132	3	2	290	121
133	3	2	290	121
134	3	3	280	121
135	3	3	280	121
136	4	2	280	121
137	3	4	275	121
138	2	4	260	121
139	3	2	300	121
140	3	2	300	121
141	3	3	270	121
142	3	3	270	121
143	4	2	300	121
144	4	2	300	121
145	4	2	0	121
146	4	4	0	121
147	4	3	330	121
148	4	4	330	121
149	4	3	310	121
150	4	4	315	121
151	3	3	330	121
152	3	3	330	121
153	4	4	35	152
154	4	4	340	152

APPENDIX B

**MONTHLY MEAN TOTAL SHADE VALUES
COMPUTED BY SHADE MODEL PRIOR TO CALIBRATION**

Table B1. Monthly mean total shade coefficients computed by shade model

Upper reach of the Tualatin River (RM 63.9 to 38.4)

```

*****
DAFLOW/BLTM      MAY    JUNE    JULY    AUG    SEPT    OCT    NOV    DEC
*****
BRANCH 1
SEGMENT:  1  0.3100  0.3150  0.3129  0.3069  0.3099  0.3963  0.8635  1.0000
SEGMENT:  2  0.3567  0.3507  0.3540  0.3685  0.3975  0.4448  0.4924  0.5305
SEGMENT:  3  0.3028  0.3036  0.3047  0.3018  0.3009  0.3509  0.7187  1.0000
SEGMENT:  4  0.3030  0.3064  0.3053  0.3025  0.3021  0.3533  0.7076  1.0000
SEGMENT:  5  0.2977  0.2991  0.2989  0.2997  0.3129  0.3579  0.4577  0.5672
SEGMENT:  6  0.2977  0.2991  0.2989  0.2997  0.3129  0.3579  0.4577  0.5672
SEGMENT:  7  0.4851  0.4793  0.4827  0.4955  0.5195  0.5507  0.5619  0.5812
SEGMENT:  8  0.4991  0.4958  0.4978  0.5062  0.5206  0.5382  0.5316  0.5401
SEGMENT:  9  0.4991  0.4958  0.4978  0.5062  0.5206  0.5382  0.5316  0.5401
SEGMENT: 10  0.5016  0.4985  0.5004  0.5083  0.5215  0.5368  0.5276  0.5346
SEGMENT: 11  0.4864  0.4834  0.4853  0.4927  0.5039  0.5149  0.4997  0.5037
           0.7506  0.7483  0.7499  0.7560  0.7653  0.7730  0.7535  0.7556

BRANCH 2
SEGMENT:  s1  0.2007  0.1930  0.1971  0.2138  0.2410  0.2742  0.2864  0.3019
SEGMENT:  s2  0.2887  0.2765  0.2828  0.3097  0.3600  0.4386  0.5277  0.5853
SEGMENT:  s3  0.3091  0.3154  0.3126  0.3059  0.3037  0.3900  0.8901  1.0000
SEGMENT:  s4  0.3967  0.3918  0.3946  0.4060  0.4243  0.4452  0.4422  0.4513
SEGMENT:  s5  0.5251  0.5202  0.5228  0.5336  0.5507  0.6106  0.9098  1.0000
SEGMENT:  s7  0.5729  0.5812  0.5793  0.5624  0.5518  0.6053  0.9353  1.0000
SEGMENT:  s7  0.6470  0.6515  0.6497  0.6455  0.6475  0.6649  0.6922  0.7269
SEGMENT:  s8  0.4820  0.4738  0.4784  0.4968  0.5325  0.5830  0.6270  0.6672
SEGMENT:  s9  0.4933  0.4710  0.4828  0.5186  0.5459  0.5626  0.6108  0.6852
SEGMENT: s10  0.2865  0.2843  0.2861  0.2913  0.3052  0.3401  0.3992  0.4700
SEGMENT: s11  0.7630  0.7514  0.7577  0.7791  0.8087  0.8391  0.8346  0.8430
           0.5942  0.5940  0.5946  0.5973  0.6035  0.6119  0.5991  0.6063

BRANCH 3
SEGMENT: 12  0.7506  0.7483  0.7499  0.7560  0.7653  0.7730  0.7535  0.7556
SEGMENT: 13  0.3015  0.2983  0.3003  0.3084  0.3218  0.3365  0.3260  0.3325
SEGMENT: 14  0.4121  0.4079  0.4104  0.4201  0.4359  0.4534  0.4453  0.4525
SEGMENT: 15  0.6595  0.6487  0.6543  0.6768  0.7137  0.7570  0.7721  0.7889
SEGMENT: 16  0.4918  0.4867  0.4896  0.5021  0.5252  0.5558  0.5675  0.5874
SEGMENT: 17  0.7484  0.7294  0.7402  0.7701  0.8079  0.8421  0.8318  0.8395
SEGMENT: 18  0.7006  0.6983  0.6999  0.7064  0.7179  0.7309  0.7176  0.7240
SEGMENT: 19  0.5137  0.5110  0.5128  0.5197  0.5308  0.5418  0.5263  0.5303
SEGMENT: 20  0.4890  0.4780  0.4846  0.5029  0.5301  0.5632  0.5739  0.5989
SEGMENT: 21  0.5134  0.5107  0.5125  0.5194  0.5307  0.5419  0.5269  0.5311
SEGMENT: 22  0.3075  0.3074  0.3083  0.3079  0.3100  0.3285  0.3581  0.4054
SEGMENT: 23  0.4891  0.4818  0.4861  0.5013  0.5274  0.5615  0.5741  0.5956
           0.3944  0.3848  0.3898  0.4102  0.4447  0.4868  0.5056  0.5249

```

Table B1. Monthly mean total shade coefficients computed by shade model—Continued

Upper reach of the Tualatin River (RM 63.9 to 38.4)—Continued

```

*****
DAFLOW/BLTM      MAY   JUNE   JULY   AUG   SEPT   OCT   NOV   DEC
*****
BRANCH 4
SEGMENT:  g1  0.5942  0.5940  0.5946  0.5973  0.6035  0.6119  0.5991  0.6063
SEGMENT:  g2  0.4642  0.4542  0.4596  0.4813  0.5192  0.5673  0.5972  0.6271
SEGMENT:  g3  0.4255  0.4233  0.4249  0.4311  0.4412  0.4517  0.4369  0.4418
SEGMENT:  g4  0.6423  0.6234  0.6331  0.6692  0.7237  0.7859  0.8127  0.8319
SEGMENT:  g5  0.4075  0.4188  0.4137  0.3968  0.3812  0.3800  0.3889  0.4198
SEGMENT:  g6  0.6720  0.6676  0.6702  0.6806  0.6974  0.7144  0.7048  0.7114
SEGMENT:  g7  0.3367  0.3403  0.3389  0.3362  0.3395  0.3574  0.3758  0.4069
SEGMENT:  g8  0.2829  0.2807  0.2821  0.2903  0.3093  0.3436  0.3730  0.4065
SEGMENT:  g9  0.5653  0.5671  0.5666  0.5664  0.5699  0.5823  0.5844  0.6045
           0.7595  0.7575  0.7590  0.7647  0.7739  0.7822  0.7634  0.7660

BRANCH 5
SEGMENT:  24  0.3944  0.3848  0.3898  0.4102  0.4447  0.4868  0.5056  0.5249
SEGMENT:  25  0.5175  0.5104  0.5143  0.5296  0.5544  0.5838  0.5864  0.5973
SEGMENT:  26  0.5697  0.5455  0.5579  0.6029  0.6720  0.7495  0.7873  0.8089
SEGMENT:  27  0.3979  0.3844  0.3915  0.4176  0.4600  0.5110  0.5343  0.5552
SEGMENT:  28  0.3979  0.3844  0.3915  0.4176  0.4600  0.5110  0.5343  0.5552
SEGMENT:  29  0.2260  0.2064  0.2154  0.2584  0.2920  0.3090  0.3190  0.3536
SEGMENT:  30  0.2875  0.2843  0.2863  0.2942  0.3073  0.3215  0.3102  0.3162
SEGMENT:  31  0.2648  0.2497  0.2567  0.2847  0.2986  0.3114  0.3303  0.3725
SEGMENT:  32  0.5539  0.5521  0.5534  0.5589  0.5681  0.5762  0.5582  0.5614
SEGMENT:  33  0.4638  0.4559  0.4601  0.4781  0.5071  0.5438  0.5552  0.5732
SEGMENT:  34  0.6151  0.6107  0.6132  0.6234  0.6400  0.6573  0.6469  0.6528
SEGMENT:  35  0.2923  0.2844  0.2878  0.3034  0.3037  0.3115  0.3303  0.3725
SEGMENT:  36  0.6059  0.6031  0.6049  0.6120  0.6236  0.6350  0.6192  0.6220
SEGMENT:  37  0.6360  0.6235  0.6299  0.6559  0.6954  0.7423  0.7603  0.7783
SEGMENT:  38  0.3189  0.3204  0.3200  0.3205  0.3257  0.3394  0.3409  0.3596
SEGMENT:  39  0.5585  0.5565  0.5579  0.5638  0.5735  0.5824  0.5643  0.5671
           0.5756  0.5114  0.5411  0.6528  0.7276  0.7508  0.7345  0.7490

BRANCH 6
SEGMENT:  40  0.5756  0.5114  0.5411  0.6528  0.7276  0.7508  0.7345  0.7490
SEGMENT:  41  0.6422  0.6385  0.6407  0.6496  0.6643  0.6785  0.6672  0.6733
SEGMENT:  42  0.4260  0.3834  0.4023  0.4886  0.5455  0.5534  0.5547  0.5839
SEGMENT:  43  0.6337  0.6270  0.6306  0.6457  0.6691  0.6976  0.7001  0.7132
SEGMENT:  44  0.4724  0.4670  0.4700  0.4826  0.5033  0.5301  0.5345  0.5495
SEGMENT:  45  0.4867  0.4838  0.4856  0.4931  0.5053  0.5177  0.5032  0.5072
SEGMENT:  46  0.3382  0.3381  0.3386  0.3410  0.3469  0.3548  0.3406  0.3475
SEGMENT:  47  0.5472  0.5468  0.5474  0.5504  0.5571  0.5647  0.5478  0.5531
SEGMENT:  48  0.6022  0.5957  0.5992  0.6136  0.6369  0.6645  0.6648  0.6750
SEGMENT:  49  0.4945  0.4869  0.4915  0.5044  0.5243  0.5502  0.5498  0.5630
SEGMENT:  50  0.5862  0.5833  0.5851  0.5924  0.6040  0.6154  0.6006  0.6044
SEGMENT:  51  0.4514  0.4442  0.4482  0.4629  0.4887  0.5209  0.5300  0.5469
SEGMENT:  52  0.4691  0.4660  0.4679  0.4755  0.4879  0.5010  0.4886  0.4932
SEGMENT:  53  0.4689  0.4390  0.4545  0.4955  0.5263  0.5543  0.5475  0.5640
SEGMENT:  54  0.6496  0.6463  0.6483  0.6565  0.6707  0.6867  0.6753  0.6816
SEGMENT:  55  0.6176  0.5565  0.5839  0.7152  0.8205  0.8478  0.8207  0.8265
SEGMENT:  56  0.6799  0.6629  0.6715  0.7034  0.7497  0.8006  0.8124  0.8237
           0.5603  0.5497  0.5553  0.5770  0.6134  0.6563  0.6733  0.6904

```

Table B1. Monthly mean total shade coefficients computed by shade model—Continued

Upper reach of the Tualatin River (RM 63.9 to 38.4)—Continued

```

*****
DAFLOW/BLTM      MAY   JUNE   JULY   AUG   SEPT   OCT   NOV   DEC
*****
BRANCH 7
SEGMENT:  57 0.5603 0.5497 0.5553 0.5770 0.6134 0.6563 0.6733 0.6904
SEGMENT:  58 0.6261 0.6159 0.6214 0.6407 0.6714 0.7076 0.7151 0.7288
SEGMENT:  59 0.6022 0.5957 0.5992 0.6136 0.6369 0.6645 0.6648 0.6750
SEGMENT:  60 0.4284 0.3972 0.4110 0.4824 0.5368 0.5537 0.5457 0.5663
SEGMENT:  61 0.5184 0.5167 0.5179 0.5233 0.5337 0.5460 0.5339 0.5411
SEGMENT:  62 0.6943 0.6888 0.6919 0.7042 0.7252 0.7494 0.7465 0.7567
SEGMENT:  63 0.2902 0.2830 0.2861 0.3008 0.3034 0.3119 0.3176 0.3478
SEGMENT:  64 0.5890 0.5347 0.5646 0.6427 0.7365 0.8203 0.8218 0.8253
SEGMENT:  65 0.4116 0.4163 0.4145 0.4081 0.4010 0.3938 0.3670 0.3699
SEGMENT:  66 0.4635 0.4597 0.4620 0.4713 0.4873 0.5064 0.4999 0.5086
SEGMENT:  67 0.5611 0.5477 0.5548 0.5803 0.6218 0.6706 0.6908 0.7100
SEGMENT:  68 0.2175 0.1979 0.2072 0.2532 0.2952 0.3064 0.3159 0.3508
SEGMENT:  69 0.4577 0.4529 0.4556 0.4669 0.4871 0.5118 0.5136 0.5263
SEGMENT:  70 0.5642 0.5392 0.5525 0.5955 0.6553 0.7177 0.7293 0.7378
SEGMENT:  71 0.4116 0.4163 0.4145 0.4081 0.4010 0.3938 0.3670 0.3699
           0.4443 0.4173 0.4324 0.4677 0.5051 0.5447 0.5424 0.5539

BRANCH 8
SEGMENT:  d1 0.7595 0.7575 0.7590 0.7647 0.7739 0.7822 0.7634 0.7660
SEGMENT:  d2 0.7107 0.7086 0.7101 0.7161 0.7261 0.7363 0.7213 0.7262
SEGMENT:  d3 0.5273 0.5239 0.5260 0.5350 0.5524 0.5770 0.5835 0.6012
SEGMENT:  d4 0.5167 0.5104 0.5141 0.5268 0.5455 0.5745 0.6059 0.6552
SEGMENT:  d5 0.6121 0.6143 0.6137 0.6123 0.6137 0.6191 0.6080 0.6192
           0.6121 0.6143 0.6137 0.6123 0.6137 0.6191 0.6080 0.6192

BRANCH 9
SEGMENT:  72 0.4443 0.4173 0.4324 0.4677 0.5051 0.5447 0.5424 0.5539
SEGMENT:  73 0.5289 0.5255 0.5276 0.5358 0.5488 0.5603 0.5459 0.5497
SEGMENT:  74 0.4711 0.4660 0.4689 0.4812 0.5020 0.5298 0.5338 0.5482
SEGMENT:  75 0.5386 0.5223 0.5305 0.5636 0.6139 0.6735 0.6995 0.7185
SEGMENT:  76 0.5115 0.5091 0.5106 0.5170 0.5267 0.5370 0.5229 0.5271
SEGMENT:  77 0.5161 0.5025 0.5094 0.5369 0.5788 0.6311 0.6570 0.6776
SEGMENT:  78 0.4590 0.4342 0.4482 0.4795 0.5114 0.5463 0.5424 0.5539
SEGMENT:  79 0.4724 0.4691 0.4711 0.4792 0.4919 0.5035 0.4894 0.4933
SEGMENT:  80 0.4963 0.4420 0.4709 0.5495 0.6389 0.7221 0.7269 0.7323
SEGMENT:  81 0.5386 0.5223 0.5305 0.5636 0.6139 0.6735 0.6995 0.7185
SEGMENT:  82 0.4221 0.4045 0.4141 0.4436 0.4855 0.5328 0.5421 0.5541
SEGMENT:  83 0.4221 0.4045 0.4141 0.4436 0.4855 0.5328 0.5421 0.5541
SEGMENT:  84 0.5372 0.5309 0.5343 0.5481 0.5689 0.5934 0.5937 0.6035
SEGMENT:  85 0.3599 0.3263 0.3411 0.4262 0.5401 0.5508 0.5382 0.5556
SEGMENT:  86 0.3599 0.3263 0.3411 0.4262 0.5401 0.5508 0.5382 0.5556
SEGMENT:  87 0.5496 0.5477 0.5491 0.5544 0.5624 0.5697 0.5516 0.5541
SEGMENT:  88 0.5666 0.5631 0.5652 0.5736 0.5867 0.5982 0.5836 0.5873
SEGMENT:  89 0.5921 0.5350 0.5655 0.6463 0.7357 0.8181 0.8192 0.8215
           0.2007 0.1930 0.1971 0.2138 0.2410 0.2742 0.2864 0.3019

```

Table B2. Monthly mean total shade coefficients computed by shade model

Lower reach of the Tualatin River (RM 38.4 to 3.4)

```

*****
CE-QUAL-W2      MAY   JUNE   JULY   AUG   SEPT   OCT   NOV   DEC
*****

SEGMENT:  2      0.3916 0.3393 0.3621 0.4902 0.7327 0.8496 0.8569 0.8217
SEGMENT:  3      0.2122 0.2031 0.2067 0.2305 0.2633 0.3034 0.3350 0.3177
SEGMENT:  4      0.3156 0.3079 0.3115 0.3262 0.3490 0.3805 0.4158 0.4035
SEGMENT:  5      0.3191 0.2891 0.3022 0.3689 0.4554 0.5386 0.5725 0.5467

SEGMENT:  6      0.3751 0.3069 0.3378 0.4796 0.6606 0.8174 0.8575 0.8215
SEGMENT:  7      0.2861 0.2852 0.2857 0.2875 0.2906 0.2951 0.2996 0.2714
SEGMENT:  8      0.4164 0.4007 0.4082 0.4385 0.4883 0.5527 0.6240 0.6294
SEGMENT:  9      0.2616 0.2593 0.2604 0.2652 0.2745 0.2889 0.3093 0.2888
SEGMENT: 10      0.3278 0.3249 0.3262 0.3318 0.3410 0.3534 0.3664 0.3437

SEGMENT: 11      0.3497 0.3439 0.3467 0.3579 0.3769 0.4030 0.4312 0.4172
SEGMENT: 12      0.2870 0.2798 0.2832 0.2973 0.3207 0.3528 0.3874 0.3772
SEGMENT: 13      0.2243 0.2213 0.2228 0.2288 0.2407 0.2607 0.2888 0.2720
SEGMENT: 14      0.2437 0.2133 0.2281 0.2815 0.3590 0.4592 0.5520 0.5318
SEGMENT: 15      0.4584 0.4526 0.4554 0.4664 0.4841 0.5074 0.5323 0.5166

SEGMENT: 16      0.4392 0.4323 0.4356 0.4487 0.4678 0.4928 0.5204 0.5070
SEGMENT: 17      0.3215 0.3152 0.3182 0.3304 0.3496 0.3752 0.4049 0.3915
SEGMENT: 18      0.4045 0.3993 0.4018 0.4115 0.4256 0.4439 0.4641 0.4466
SEGMENT: 19      0.3603 0.3460 0.3529 0.3794 0.4228 0.4830 0.5527 0.5597
SEGMENT: 20      0.2819 0.2728 0.2771 0.2946 0.3229 0.3646 0.4140 0.4115

SEGMENT: 21      0.2879 0.2798 0.2837 0.2987 0.3232 0.3588 0.4002 0.3949
SEGMENT: 22      0.3027 0.2977 0.3001 0.3097 0.3253 0.3457 0.3654 0.3493
SEGMENT: 23      0.2963 0.2903 0.2931 0.3047 0.3242 0.3509 0.3803 0.3694
SEGMENT: 24      0.2010 0.1811 0.1898 0.2381 0.3308 0.4619 0.5576 0.5226
SEGMENT: 25      0.3701 0.3515 0.3603 0.3965 0.4554 0.5384 0.6330 0.6535

SEGMENT: 26      0.4081 0.3982 0.4029 0.4211 0.4508 0.4937 0.5432 0.5427
SEGMENT: 27      0.2602 0.2282 0.2422 0.3212 0.5128 0.7738 0.8528 0.8117
SEGMENT: 28      0.3853 0.3777 0.3814 0.3960 0.4200 0.4514 0.4831 0.4739
SEGMENT: 29      0.2750 0.2648 0.2696 0.2897 0.3229 0.3719 0.4306 0.4315
SEGMENT: 30      0.2637 0.2533 0.2584 0.2778 0.3112 0.3599 0.4188 0.4218

SEGMENT: 31      0.2637 0.2533 0.2584 0.2778 0.3112 0.3599 0.4188 0.4218
SEGMENT: 32      0.2706 0.2652 0.2678 0.2779 0.2934 0.3143 0.3378 0.3250
SEGMENT: 33      0.2200 0.1947 0.2059 0.2663 0.3853 0.5618 0.7323 0.7126
SEGMENT: 34      0.2002 0.1935 0.1967 0.2097 0.2317 0.2612 0.2949 0.2898
SEGMENT: 35      0.2723 0.2450 0.2578 0.3114 0.4031 0.5431 0.7178 0.7761

SEGMENT: 36      0.1790 0.1683 0.1727 0.2024 0.2704 0.3858 0.5218 0.5155
SEGMENT: 37      0.2150 0.1948 0.2035 0.2537 0.3582 0.5231 0.7069 0.7113
SEGMENT: 38      0.1839 0.1681 0.1744 0.2196 0.3531 0.5832 0.7425 0.7109
SEGMENT: 39      0.2082 0.1901 0.1974 0.2487 0.4002 0.6607 0.8400 0.8089
SEGMENT: 40      0.2584 0.2366 0.2467 0.2898 0.3650 0.4832 0.6353 0.6825

```

Table B2. Monthly mean total shade coefficients computed by shade model—Continued

Lower reach of the Tualatin River (RM 38.4 to 3.4)—Continued

```

*****
CE-QUAL-W2      MAY    JUNE    JULY    AUG    SEPT    OCT    NOV    DEC
*****
SEGMENT:  41      0.3429  0.3364  0.3395  0.3520  0.3720  0.3958  0.4210  0.4112
SEGMENT:  42      0.2807  0.2631  0.2715  0.3050  0.3625  0.4501  0.5606  0.5942
SEGMENT:  43      0.2163  0.1966  0.2051  0.2546  0.3604  0.5338  0.7430  0.7941
SEGMENT:  44      0.2163  0.1966  0.2051  0.2546  0.3604  0.5338  0.7430  0.7941
SEGMENT:  45      0.1721  0.1569  0.1635  0.2019  0.2860  0.4276  0.6071  0.6588

SEGMENT:  46      0.1721  0.1569  0.1635  0.2019  0.2860  0.4276  0.6071  0.6588
SEGMENT:  47      0.2274  0.2130  0.2198  0.2478  0.2976  0.3769  0.4813  0.5196
SEGMENT:  48      0.1603  0.1430  0.1506  0.1928  0.2819  0.4270  0.6071  0.6588
SEGMENT:  49      0.1948  0.1776  0.1850  0.2286  0.3240  0.4842  0.6870  0.7504
SEGMENT:  50      0.2492  0.2380  0.2433  0.2652  0.3026  0.3607  0.4349  0.4555

SEGMENT:  51      0.1207  0.1132  0.1163  0.1384  0.2072  0.3353  0.4757  0.4971
SEGMENT:  52      0.1207  0.1132  0.1163  0.1384  0.2072  0.3353  0.4757  0.4971
SEGMENT:  53      0.1878  0.1791  0.1832  0.2003  0.2320  0.2850  0.3584  0.3773
SEGMENT:  54      0.2047  0.1992  0.2018  0.2124  0.2299  0.2538  0.2826  0.2767
SEGMENT:  55      0.1019  0.0973  0.0995  0.1085  0.1243  0.1492  0.1818  0.1755

SEGMENT:  56      0.2698  0.2563  0.2627  0.2888  0.3333  0.4014  0.4874  0.5153
SEGMENT:  57      0.2454  0.2305  0.2376  0.2665  0.3154  0.3888  0.4800  0.5104
SEGMENT:  58      0.1424  0.1289  0.1344  0.1714  0.2775  0.4686  0.6591  0.6973
SEGMENT:  59      0.1468  0.1350  0.1396  0.1738  0.2777  0.4686  0.6591  0.6973
SEGMENT:  60      0.2496  0.2432  0.2462  0.2585  0.2776  0.3034  0.3327  0.3278

SEGMENT:  61      0.3042  0.2969  0.3004  0.3142  0.3355  0.3643  0.3967  0.3935
SEGMENT:  62      0.2976  0.2892  0.2932  0.3096  0.3364  0.3729  0.4164  0.4192
SEGMENT:  63      0.1424  0.1289  0.1344  0.1714  0.2775  0.4686  0.6591  0.6973
SEGMENT:  64      0.2273  0.2072  0.2165  0.2574  0.3318  0.4529  0.6165  0.6841
SEGMENT:  65      0.1428  0.1312  0.1365  0.1611  0.2089  0.2921  0.4124  0.4688

SEGMENT:  66      0.1428  0.1312  0.1365  0.1611  0.2089  0.2921  0.4124  0.4688
SEGMENT:  67      0.2193  0.1982  0.2079  0.2508  0.3278  0.4515  0.6164  0.6841
SEGMENT:  68      0.1640  0.1497  0.1554  0.1957  0.3146  0.5309  0.7461  0.7945
SEGMENT:  69      0.2704  0.2561  0.2630  0.2908  0.3395  0.4162  0.5155  0.5516
SEGMENT:  70      0.1458  0.1305  0.1372  0.1759  0.2791  0.4566  0.6462  0.6891

SEGMENT:  71      0.2449  0.2399  0.2423  0.2517  0.2663  0.2859  0.3079  0.2986
SEGMENT:  72      0.1963  0.1779  0.1867  0.2221  0.2846  0.3824  0.5094  0.5593
SEGMENT:  73      0.2235  0.2081  0.2154  0.2454  0.3000  0.3894  0.5108  0.5593
SEGMENT:  74      0.2144  0.1980  0.2058  0.2377  0.2949  0.3871  0.5103  0.5593
SEGMENT:  75      0.2081  0.2013  0.2045  0.2178  0.2413  0.2792  0.3299  0.3360

SEGMENT:  76      0.2081  0.2013  0.2045  0.2178  0.2413  0.2792  0.3299  0.3360
SEGMENT:  77      0.2492  0.2380  0.2433  0.2652  0.3026  0.3607  0.4349  0.4555
SEGMENT:  78      0.1721  0.1569  0.1635  0.2019  0.2860  0.4276  0.6071  0.6588
SEGMENT:  79      0.1780  0.1639  0.1699  0.2064  0.2881  0.4279  0.6071  0.6588
SEGMENT:  80      0.1468  0.1350  0.1396  0.1738  0.2777  0.4686  0.6591  0.6973

```

Table B2. Monthly mean total shade coefficients computed by shade model—Continued

Lower reach of the Tualatin River (RM 38.4 to 3.4)—Continued

```

*****
CE-QUAL-W2      MAY    JUNE    JULY    AUG    SEPT    OCT    NOV    DEC
*****
SEGMENT:  81    0.2684 0.2627 0.2654 0.2759 0.2928 0.3153 0.3399 0.3327
SEGMENT:  82    0.1761 0.1669 0.1713 0.1894 0.2213 0.2719 0.3379 0.3521
SEGMENT:  83    0.1622 0.1440 0.1520 0.1973 0.3157 0.5173 0.7315 0.7851
SEGMENT:  84    0.2649 0.2568 0.2607 0.2759 0.3023 0.3416 0.3898 0.3979
SEGMENT:  85    0.1966 0.1914 0.1939 0.2046 0.2246 0.2578 0.3031 0.3088

SEGMENT:  86    0.1276 0.1210 0.1237 0.1427 0.1905 0.2798 0.4031 0.4351
SEGMENT:  87    0.2219 0.2120 0.2167 0.2364 0.2714 0.3257 0.3956 0.4164
SEGMENT:  88    0.1294 0.1193 0.1233 0.1525 0.2430 0.4131 0.5944 0.6471
SEGMENT:  89    0.0952 0.0879 0.0907 0.1120 0.1782 0.3032 0.4372 0.4661
SEGMENT:  90    0.2708 0.2647 0.2676 0.2795 0.2990 0.3236 0.3502 0.3459

SEGMENT:  91    0.1532 0.1404 0.1459 0.1802 0.2786 0.4568 0.6599 0.7249
SEGMENT:  92    0.2814 0.2738 0.2774 0.2921 0.3170 0.3514 0.3903 0.3936
SEGMENT:  93    0.1767 0.1615 0.1684 0.1998 0.2584 0.3563 0.4920 0.5469
SEGMENT:  94    0.1767 0.1615 0.1684 0.1998 0.2584 0.3563 0.4920 0.5469
SEGMENT:  95    0.1635 0.1562 0.1597 0.1742 0.2001 0.2406 0.2929 0.3020

SEGMENT:  96    0.1308 0.1203 0.1246 0.1540 0.2438 0.4105 0.5917 0.6445
SEGMENT:  97    0.1308 0.1203 0.1246 0.1540 0.2438 0.4105 0.5917 0.6445
SEGMENT:  98    0.1353 0.1241 0.1289 0.1591 0.2459 0.4032 0.5829 0.6360
SEGMENT:  99    0.1294 0.1193 0.1233 0.1525 0.2430 0.4131 0.5944 0.6471
SEGMENT: 100    0.1353 0.1241 0.1289 0.1591 0.2459 0.4032 0.5829 0.6360

SEGMENT: 101    0.1622 0.1451 0.1530 0.1878 0.2512 0.3538 0.4919 0.5469
SEGMENT: 102    0.2551 0.2490 0.2519 0.2637 0.2831 0.3077 0.3344 0.3303
SEGMENT: 103    0.1559 0.1381 0.1459 0.1888 0.2797 0.4293 0.6196 0.6876
SEGMENT: 104    0.2573 0.2513 0.2541 0.2655 0.2840 0.3066 0.3307 0.3250
SEGMENT: 105    0.2000 0.1827 0.1906 0.2263 0.2926 0.4034 0.5567 0.6229

SEGMENT: 106    0.2691 0.2596 0.2641 0.2822 0.3125 0.3582 0.4130 0.4259
SEGMENT: 107    0.1465 0.1350 0.1396 0.1728 0.2754 0.4680 0.6730 0.7376
SEGMENT: 108    0.1407 0.1294 0.1342 0.1652 0.2551 0.4197 0.6123 0.6814
SEGMENT: 109    0.1579 0.1445 0.1503 0.1845 0.2618 0.3963 0.5758 0.6447
SEGMENT: 110    0.1579 0.1445 0.1503 0.1845 0.2618 0.3963 0.5758 0.6447

SEGMENT: 111    0.2217 0.2104 0.2158 0.2377 0.2771 0.3370 0.4160 0.4427
SEGMENT: 112    0.1529 0.1386 0.1448 0.1807 0.2600 0.3960 0.5758 0.6447
SEGMENT: 113    0.1444 0.1335 0.1382 0.1667 0.2328 0.3501 0.5087 0.5656
SEGMENT: 114    0.1328 0.1218 0.1262 0.1573 0.2518 0.4296 0.6248 0.6920
SEGMENT: 115    0.2442 0.2377 0.2408 0.2529 0.2731 0.3023 0.3351 0.3351

SEGMENT: 116    0.1969 0.1924 0.1946 0.2031 0.2174 0.2382 0.2616 0.2558
SEGMENT: 117    0.1026 0.0940 0.0977 0.1197 0.1696 0.2570 0.3744 0.4075
SEGMENT: 118    0.1196 0.1095 0.1141 0.1351 0.1749 0.2426 0.3374 0.3697
SEGMENT: 119    0.1579 0.1445 0.1503 0.1845 0.2618 0.3963 0.5758 0.6447
SEGMENT: 120    0.1407 0.1294 0.1342 0.1652 0.2551 0.4197 0.6123 0.6814

```

Table B2. Monthly mean total shade coefficients computed by shade model—Continued

Lower reach of the Tualatin River (RM 38.4 to 3.4)—Continued

```

*****
CE-QUAL-W2      MAY   JUNE   JULY   AUG   SEPT   OCT   NOV   DEC
*****
SEGMENT: 121    0.1407 0.1294 0.1342 0.1652 0.2551 0.4197 0.6123 0.6814
SEGMENT: 122    0.1170 0.1080 0.1117 0.1373 0.2168 0.3668 0.5360 0.5919
SEGMENT: 123    0.1892 0.1801 0.1844 0.2021 0.2329 0.2773 0.3332 0.3499
SEGMENT: 124    0.1210 0.1107 0.1151 0.1430 0.2230 0.3695 0.5456 0.6120
SEGMENT: 125    0.1734 0.1641 0.1685 0.1871 0.2206 0.2755 0.3490 0.3767

SEGMENT: 126    0.1094 0.1011 0.1046 0.1280 0.1972 0.3262 0.4818 0.5367
SEGMENT: 127    0.2092 0.2033 0.2061 0.2173 0.2351 0.2599 0.2889 0.2884
SEGMENT: 128    0.1447 0.1391 0.1417 0.1530 0.1741 0.2105 0.2612 0.2741
SEGMENT: 129    0.0805 0.0744 0.0770 0.0940 0.1447 0.2394 0.3542 0.3861
SEGMENT: 130    0.1434 0.1315 0.1370 0.1620 0.2102 0.2925 0.4102 0.4609

SEGMENT: 131    0.1348 0.1225 0.1278 0.1588 0.2285 0.3500 0.5138 0.5795
SEGMENT: 132    0.0994 0.0937 0.0960 0.1121 0.1522 0.2275 0.3338 0.3659
SEGMENT: 133    0.0994 0.0937 0.0960 0.1121 0.1522 0.2275 0.3338 0.3659
SEGMENT: 134    0.1094 0.1011 0.1046 0.1280 0.1972 0.3262 0.4818 0.5367
SEGMENT: 135    0.1094 0.1011 0.1046 0.1280 0.1972 0.3262 0.4818 0.5367

SEGMENT: 136    0.0893 0.0856 0.0870 0.1000 0.1463 0.2394 0.3542 0.3861
SEGMENT: 137    0.1176 0.1080 0.1120 0.1389 0.2210 0.3755 0.5536 0.6210
SEGMENT: 138    0.0893 0.0856 0.0870 0.1000 0.1463 0.2394 0.3542 0.3861
SEGMENT: 139    0.1177 0.1106 0.1138 0.1292 0.1606 0.2173 0.3022 0.3321
SEGMENT: 140    0.1177 0.1106 0.1138 0.1292 0.1606 0.2173 0.3022 0.3321

SEGMENT: 141    0.1048 0.0971 0.1002 0.1226 0.1945 0.3331 0.4911 0.5476
SEGMENT: 142    0.1048 0.0971 0.1002 0.1226 0.1945 0.3331 0.4911 0.5476
SEGMENT: 143    0.1238 0.1174 0.1203 0.1343 0.1636 0.2184 0.3023 0.3321
SEGMENT: 144    0.1238 0.1174 0.1203 0.1343 0.1636 0.2184 0.3023 0.3321
SEGMENT: 145    0.1997 0.1949 0.1972 0.2064 0.2214 0.2416 0.2639 0.2593

SEGMENT: 146    0.2419 0.2361 0.2388 0.2499 0.2679 0.2920 0.3186 0.3164
SEGMENT: 147    0.2063 0.1997 0.2028 0.2158 0.2387 0.2724 0.3159 0.3250
SEGMENT: 148    0.2213 0.2135 0.2172 0.2327 0.2599 0.2996 0.3505 0.3643
SEGMENT: 149    0.1720 0.1623 0.1669 0.1861 0.2221 0.2831 0.3676 0.4022
SEGMENT: 150    0.1963 0.1858 0.1907 0.2118 0.2497 0.3118 0.3947 0.4290

SEGMENT: 151    0.1956 0.1886 0.1919 0.2056 0.2297 0.2650 0.3101 0.3202
SEGMENT: 152    0.1956 0.1886 0.1919 0.2056 0.2297 0.2650 0.3101 0.3202
SEGMENT: 153    0.1754 0.1680 0.1715 0.1860 0.2112 0.2511 0.3032 0.3200
SEGMENT: 154    0.1913 0.1854 0.1882 0.1996 0.2189 0.2465 0.2783 0.2829

```

APPENDIX C

**WATER-TEMPERATURE SUBROUTINE CODE
OF THE UPPER STREAM SECTION HEAT TRANSPORT MODEL**

Appendix C. Water-temperature subroutine code of the upper stream section heat transport model

```

C*****
C***** U.S. GEOLOGICAL SURVEY PRELIMINARY COMPUTER PROGRAM *****
C*****
C*
C*   Program Contact/Site
C*   -----
C*   John Risley                               Phone: (503) 251-3279
C*   U. S. Geological Survey - WRD             FAX: (503) 251-3470
C*   10615 SE. Cherry Blossom Drive
C*   Portland, Oregon 97216 USA                 E-mail: jrisley@usgs.gov
C*
C*:::::::::::::::::::::::::::::::::::::::::::::::::::::::::::::::::::::
C*
C* Disclaimer:
C*   Although this program has been used by the U.S. Geological Survey,
C*   no warranty, expressed or implied, is made by the USGS as to the
C*   accuracy and functioning of the program and related program
C*   material nor shall the fact of distribution constitute any such
C*   warranty, and no responsibility is assumed by the USGS in
C*   connection therewith.
C*
C*:::::::::::::::::::::::::::::::::::::::::::::::::::::::::::::::::::::
C*
C* Purpose: Enables the user to compute heat flux using the equilibrium method
C*   with solar radiation as data input. Algorithms were developed by
C*   Harvey Jobson, U.S. Geological Survey, Reston, Virginia for the
C*   Tualatin River Temperature Study.
C*
C*:::::::::::::::::::::::::::::::::::::::::::::::::::::::::::::::::::::
C
      SUBROUTINE FINK (
I          K,MX,J,NEQ,PV,PT,
I          Q,A,W,XK,S,CR,IRC,NNN,LUOUT,
E          )
C
C   DEFINE VARIABLES:
C
C   NAME                                PURPOSE
C   -----
C   A      Average area of subreach A
C   CR(M,L) Equilibrium concentration in equation M for constituent L
C   IENG    Input units: 0=metric, 1=English
C   IRC     Code to set read for new data each time step
C   J       Time step
C   K       Parcel number
C   MX      Grid just upstream of parcel's upstream boundary
C   NEQ     Number of equations (constituents)
C   NBRCH   Number of branches N
C   NXSEC(N) Number of subreaches in branch N
C   NNN     Branch number
C   PT(L,K) Concentration of constituent L in parcel K
C   S(L)    Source flux of constituent L (units/hour)
C   ET      Equilibrium temperate (Celsius)

```

Appendix C. Water-temperature subroutine code of the upper stream section heat transport model—Continued

```

C*****
C***** U.S. GEOLOGICAL SURVEY PRELIMINARY COMPUTER PROGRAM—Continued *****
C*****
C*
C   CSHE      Heat exchange coefficient
C   W         Average top width of the subreach
C   XK(L,LL) Exchange coefficient for constituent L due to the
C             concentration of constituent LL
C   SROSH     Shading coefficients at branch, grid, month
C   sro       Shortwave solar-radiation data (ly/day)
C   tairc     Air temperature data (C)
C   tairf     Air temperature data (F)
C   tdewc     Dewpoint temperature data (C)
C   tdewf     Dewpoint temperature data (F)
C   te        Equilibrium temperature (C)
C   wind      Wind speed
C   Z         Month index for shade coefficients
C
C*** BEGIN DIMENSIONING DEFINITION
C
C   NOBR      Maximum number of branches allowed in model
C   NOSC      Maximum number of cross sections (grids) allowed in branch
C   NOPR      Maximum number of parcels allowed in branch
C             (NOPR should be at least 20 + 2 times NOSC)
C   NOCO      Maximum number of constituents allowed
C
C   INTEGER NOBR,NOSC,NOPR,NOCO,NBRCH,IENG
C   PARAMETER (NOBR=10, NOSC=20, NOPR=150, NOCO=10)
C   REAL PV,Q,W,A
C
C   + + + LOCAL VARIABLES + + +
C
C   INTEGER IRC,J,JJ,K,LUOUT,LUQ2,MX,NEQ,NNN,NXSEC(NOBR)
C   INTEGER LUSH,ii,z,kk,i,luet,lmx
C   REAL AL,A1,B1,CPR,CR(NOCO,NOCO),DAL,DB1,DFT,
C   # PT(NOCO,NOPR),PSI,
C   # S(NOCO),SIG,TE,TEB,TITLE(20),V,XK(NOCO,NOCO),XKX,
C   # srosh(nobr,nosc,8),sro,tairf,tdewf,wind,fw,ha,et,
C   # cshe,tstar,beta,etp,tairc,tdewc,hin,ea,eo,hb,ht,
C   # el,cl,slope,ten,aa
C
C   COMMON NXSEC,NBRCH,IENG
C   SAVE sro,tairf,tdewf,tairc,tdewc,wind,srosh,te
C
C   IF(IRC.NE.1)GO TO 5
C   IF(J.NE.1)GO TO 4
C
C       nxsec(1)=12
C       nxsec(2)=12
C       nxsec(3)=13
C       nxsec(4)=10
C       nxsec(5)=17
C       nxsec(6)=18

```

jcr:10/23

Appendix C. Water-temperature subroutine code of the upper stream section heat transport model—Continued

```

C*****
C***** U.S. GEOLOGICAL SURVEY PRELIMINARY COMPUTER PROGRAM—Continued *****
C*****
C*
      nxsec(7)=16
      nxsec(8)=6
      nxsec(9)=19
C
      LUQ2=20
      LUSH=14
      LUET=21
      OPEN(LUQ2,FILE='met.in')
      OPEN(LUSH,FILE='shade.in')
C      OPEN(LUET,FILE='et.out')
      READ(LUQ2,1000)
      READ(LUSH,1000)
      do 33 kk=1,9
        do 22 ii=1,nxsec(kk)
          READ(LUSH,1045)(SROSH(kk,ii,z),z=1,7)
22          continue
33          continue
          CLOSE(LUSH)
4          CONTINUE
          IF(IRC.NE.1)GO TO 5
          READ(LUQ2,1001)sro,tairc,tdewc,wind
C          WRITE(LUET,1050)j-1,te
1000  FORMAT (20A4)
1001  FORMAT(10x,4F10.4)
1045  FORMAT (13X,7F7.0)
1050  FORMAT (5X,I8,F10.4)
C
C      IF (J.EQ.10272)THEN
C          CLOSE(LUET)
C      ELSE
C          ENDIF
C
      z=1
      if(j.gt.1488) z=2
      if(j.gt.2928) z=3
      if(j.gt.4416) z=4
      if(j.gt.5904) z=5
      if(j.gt.7344) z=6
      if(j.gt.8832) z=7
C
C      Convert solar radiation data from langleys/day to Btu/(sq.ft.day)
C
      sro=sro*3.686559
C
C      Ensure that air temp. is never less than dewpoint temp.
C
      if(tairc.lt.tdewc) tairc=tdewc
C
C      Convert temperatures from degree C to degree F

```

Appendix C. Water-temperature subroutine code of the upper stream section heat transport model—Continued

```

C*****
C***** U.S. GEOLOGICAL SURVEY PRELIMINARY COMPUTER PROGRAM—Continued *****
C*****
C*
C
      tairf=(tairc+17.78)*1.8                                jcr:9/28
      tdewf=(tdewc+17.78)*1.8                                jcr:9/28
C
C      Convert wind speed from meters/sec. to mph            jcr:9/28
C
      wind=wind*2.23714                                      jcr:9/28
C
      5 CONTINUE
C
***** The units for the wind function FW are Btu/(sq.ft. day mm.Hg) jcr:9/28
***** The units on the coefficient 0.7 are                      jcr:9/28
***** (Btu sq.hr)/(sq.ft. day mm.Hg sq.mile)                  jcr:9/28
      FW = 70.0+(0.7*WIND*WIND)                               jcr:9/28

***** HA is an empirical representation of the long-wave thermal jcr:9/28
***** radiation from the Earth's atmosphere, using an emittance of jcr:9/28
***** about 0.775. The constant 3.1872E-08 is equal to the emittance jcr:9/28
***** times the Stefan-Boltzmann constant, which is equal to    jcr:9/28
***** 4.1122E-08 Btu/(sq.ft. day (deg.R to the 4th)). HA has units jcr:9/28
***** of Btu/(sq.ft. day).                                       jcr:9/28

      HA = 3.1872E-08*(TAIRF+460.)*(TAIRF+460.)*(TAIRF+460.) jcr:9/28
      .      *(TAIRF+460.)                                         jcr:9/28
C      HA = 2.0E-08*(TAIRF+460.)*(TAIRF+460.)*(TAIRF+460.) jcr:9/28
C      .      *(TAIRF+460.)                                         jcr:9/28

C      Compute incoming in cal/(cm2 day)
      SIG=1.171E-7
      HIN=(SRO*(1.0-SROSH(nnn,mx,z))+HA)/3.686559
C      WRITE(LUOUT,*)'Total incoming, cal/(cm2 day) ',HIN
C      Compute coefficient on evap and cond in cal/(cm2 day kpa)
      XKK=FW/(3.686559*0.1333)
C      XKK=(3.01+1.13*WIND/2.23714)/10.0
      TE=TAIRC
      EA=exp(52.418-(6788.6/(TDEWC+273.16))-5.0016*LOG(TDEWC+273.16))
C      WRITE(LUOUT,*)'Vapor pres of air, KPA =',EA
      DO 10 I = 1,50
C          WRITE(LUOUT,*)'Beginning TE = ',TE
          EO=exp(52.418-(6788.6/(TE+273.16))-5.0016*LOG(TE+273.16))
C          WRITE(LUOUT,*)'Sat vapor pres, KPA =',EO
          HB=0.97*1.171E-7*(TE+273.16)**4.0
C          WRITE(LUOUT,*)'Back radiation, cal/cm2 day = ',HB
          HT=HIN-HB
C          WRITE(LUOUT,*)'Incoming less back, cal/cm2 day = ',HT
          EL=XKK*(EO-EA)
C          AA=EO-EA
C          IF(AA.LT.0.0)EL=0.0
C          WRITE(LUOUT,*)'Evaproative loss EL, cal/cm2 day =',EL

```

Appendix C. Water-temperature subroutine code of the upper stream section heat transport model—Continued

```

C*****
C***** U.S. GEOLOGICAL SURVEY PRELIMINARY COMPUTER PROGRAM—Continued *****
C*****
C*
      CL=XKX*0.062*(TE-TAIRC)
C      WRITE(LUOUT,*)'Conductive heat loss CL, cal/cm2 day = ',CL
      HT=HT-EL-CL
C      WRITE(LUOUT,*)'Net heat exchange, cal/cm2 day = ',HT
      SLOPE=4.0*0.97*1.171E-7*(TE+273.16)**3.0
C      WRITE(LUOUT,*)'SLOPE = ',SLOPE
      DFT=1.1532E11*EXP(-4271.1/(TE+242.63))/((TE+242.63)**2.)
C      WRITE(LUOUT,*)'Slope of sat vap curve, KPA = ',DFT
      SLOPE=-(SLOPE+XKX*(DFT+0.062))
      TEN=TE-HT/SLOPE
      AA=ABS(TEN-TE)
      TE=TEN
C      WRITE(LUOUT,*)'Ending Te = ',TE
      IF(AA.LT.0.001)GO TO 20
10 CONTINUE
C      WRITE(*,*)'Did not converge'
20 CONTINUE
C      WRITE(LUOUT,*)'Sat vapor pres, KPA =',EO
C      WRITE(LUOUT,*)'Back radiation, cal/cm2 day = ',HB
C      WRITE(LUOUT,*)'Evaproative loss EL, cal/cm2 day = ',EL
C      WRITE(LUOUT,*)'Conductive heat loss CL, cal/cm2 day = ',CL
C
C      WRITE(LUOUT,6030)HOUR,HA,HIN,HB,EL,CL,ET,TE,TAIRC
6030 FORMAT(6F9.1,3F7.2)
      CPR=1.0
      CR(1,1)=TE
C      The variable PT must be brought into the subroutine, I will assume
C      PT = TE to check out the program,
C      K=1
C      PT(1,K)=TE
      DFT=1.1532E11*EXP(-4271.1/(PT(1,K)+242.63))
#      /((PT(1,K)+242.63)**2)
C      write(luout,*)'DFT = = ',DFT
      XKX=4.0*0.97*SIG*((PT(1,K)+273.16)**3)+XKX*(DFT+0.062)
C      write(luout,*)'XKX = ', XKX
C      XKX has units of cal/(sq cm day Kpa C)
C      CPR = specific heat times density has units of cal/cu cm
C      30.48 converts cm/day C to ft/day C
      XK(1,1)=-XKX*W/(A*CPR*30.48*24.0)
C      XK has units of per (hour C)
C      WRITE(LUOUT,*)'Heat exchange coef, per hr = ',XK(1,1)
C      GO TO 40
C 50 CONTINUE
C      CLOSE(LUOUT)
C      CLOSE(LUSH)
C      CLOSE(LUQ2)
      IRC=0
      RETURN
      END

```

APPENDIX D

**CODE MODIFICATIONS TO THE LOWER
STREAM SECTION HEAT TRANSPORT MODEL**

Appendix D. Code Modifications to the Lower Stream Section Heat Transport Model

This study used a version of CE-QUAL-W2 that was very similar to the version used in an earlier USGS water-quality modeling study of the Tualatin River (Cole and Buchak, 1995; S.A. Rounds and others, USGS unpub. data, 1995). Some minor coding modifications of the model were made for this study.

In the earlier USGS study, individual riparian vegetation shade coefficients were assigned for each cross-section segment. The magnitude of each coefficient was based on the stream width of the segment. In this study, riparian vegetation shade coefficients were computed for each segment by the IWTM model. Because the shade coefficients seasonally vary, the shade coefficients were computed for each month and the CE-QUAL-W2 code was modified so a table of monthly coefficients could be read as an input file.

As mentioned previously, the term-by-term direct energy equation was used in this study instead of the equilibrium temperature equation used by (S.A. Rounds and others, USGS unpub. data, 1995). The original code for the term-by-term direct energy equation is detailed by Cole and Buchak (1995). Some modifications to that code were made for this study. In the Cole and Buchak (1995) version, measured cloud-cover data were used as input to the model, and incoming shortwave solar radiation was estimated from those cloud cover data. In this study, incoming shortwave solar radiation data were collected directly and used as input to the model. However, cloud-cover data, which were not collected during this study, were needed to compute net long-wave solar radiation. Cloud cover data were therefore computed in a preprocessing program using the following equation:

$$C = \sqrt{\frac{\left(1 - \frac{S}{S_p}\right)}{0.65}},$$

where

S is measured incoming shortwave solar radiation, and

S_p is computed potential shortwave solar radiation

(based on the algorithm contained in the heat subroutine by Cole and Buchak [1995]).

Half-hourly cloud cover values were computed from the available half-hourly daylight values of actual short-wave solar radiation. An average cloud cover value was computed from these values for each day. (The sum of daylight values was divided by the number of daylight values). Because a cloud cover value was also required in the simulation during the night, this value was designated as cloud cover for the full 24-hour period.

APPENDIX E

FLOW.IN PARAMETER FILE FOR DAFLOW

Appendix E. Tualatin River network (RM 63.9 to 38.4)

No. of Branches 9 *
 Internal Junctions 5 *
 Time Steps Modeled 10272 *
 Model Starts 0 time steps after midnight.
 Output Given Every 01 Time Steps in FLOW.OUT.
 0=Metric,1=English 1 *
 Time Step Size 0.500 Hours.
 Peak Discharge 1000. *

Branch 1 has 12 xsects & routes 1.00 of flow at JNCT 6 To JNCT 1

Grd R Mile	IOUT	Disch	A1	A2	AO	DF	W1	W2
1 0.0000E+00	0	69.88	3.00	0.660	100.	0.109E+04	10.0	0.260
2 0.1500	0	69.88	3.00	0.660	100.	0.109E+04	10.0	0.260
3 0.4000	0	69.88	3.00	0.660	100.	0.109E+04	10.0	0.260
4 0.9000	0	69.88	3.00	0.660	100.	0.109E+04	10.0	0.260
5 1.400	0	69.33	3.00	0.660	100.	0.109E+04	10.0	0.260
6 1.650	0	69.33	3.00	0.660	100.	0.109E+04	10.0	0.260
7 1.900	0	69.33	3.00	0.660	100.	0.109E+04	10.0	0.260
8 2.000	0	69.33	3.00	0.660	100.	0.109E+04	10.0	0.260
9 2.400	0	69.00	3.00	0.660	100.	0.109E+04	10.0	0.260
10 2.900	0	69.00	3.00	0.660	100.	0.109E+04	10.0	0.260
11 3.400	0	83.00	3.00	0.660	100.	0.109E+04	10.0	0.260
12 3.900	0							

Branch 2 has 12 xsects & routes 1.00 of flow at JNCT 7 To JNCT 1

Grd R Mile	IOUT	Disch	A1	A2	AO	DF	W1	W2
1 0.0000E+00	0	21.00	3.00	0.660	100.	0.109E+04	10.0	0.260
2 0.3000	0	21.00	3.00	0.660	100.	0.109E+04	10.0	0.260
3 0.9000	0	21.00	3.00	0.660	100.	0.109E+04	10.0	0.260
4 1.500	0	21.00	3.00	0.660	100.	0.109E+04	10.0	0.260
5 1.800	0	21.00	3.00	0.660	100.	0.109E+04	10.0	0.260
6 2.300	0	21.00	3.00	0.660	100.	0.109E+04	10.0	0.260
7 2.800	0	21.00	3.00	0.660	100.	0.109E+04	10.0	0.260
8 3.100	0	21.00	3.00	0.660	100.	0.109E+04	10.0	0.260
9 3.400	0	21.00	3.00	0.660	100.	0.109E+04	10.0	0.260
10 4.000	0	21.00	3.00	0.660	100.	0.109E+04	10.0	0.260
11 4.300	0	21.00	3.00	0.660	100.	0.109E+04	10.0	0.260
12 4.800	0							

Branch 3 has 13 xsects & routes 1.00 of flow at JNCT 1 To JNCT 2

Grd R Mile	IOUT	Disch	A1	A2	AO	DF	W1	W2
1 3.900	0	104.0	3.00	0.660	100.	0.109E+04	10.0	0.260
2 4.300	0	104.0	3.00	0.660	100.	0.109E+04	10.0	0.260
3 4.550	0	103.5	3.00	0.660	100.	0.109E+04	10.0	0.260
4 4.800	0	103.5	3.00	0.660	100.	0.109E+04	10.0	0.260
5 5.000	1	103.5	3.00	0.660	100.	0.109E+04	10.0	0.260
6 5.400	0	103.5	3.00	0.660	100.	0.109E+04	10.0	0.260
7 5.600	0	103.5	3.00	0.660	100.	0.109E+04	10.0	0.260
8 5.900	0	103.5	3.00	0.660	100.	0.109E+04	10.0	0.260
9 6.200	0	103.5	3.00	0.660	100.	0.109E+04	10.0	0.260
10 6.400	0	102.9	3.00	0.660	100.	0.109E+04	10.0	0.260
11 6.650	0	102.9	3.00	0.660	100.	0.109E+04	10.0	0.260
12 6.900	0	102.9	3.00	0.660	100.	0.109E+04	10.0	0.260
13 7.200	0							

Appendix E. Tualatin River network (RM 63.9 to 38.4)—Continued

Branch 4 has 10 xsects & routes 1.00 of flow at JNCT 8 To JNCT 2

Grd	R Mile	IOUT	Disch	A1	A2	AO	DF	W1	W2
1	0.0000E+00	0	95.00	3.00	0.660	100.	0.109E+04	10.0	0.260
2	0.2000	0	95.00	3.00	0.660	100.	0.109E+04	10.0	0.260
3	0.4000	0	95.00	3.00	0.660	100.	0.109E+04	10.0	0.260
4	0.7000	0	95.00	3.00	0.660	100.	0.109E+04	10.0	0.260
5	1.100	0	95.00	3.00	0.660	100.	0.109E+04	10.0	0.260
6	1.200	0	95.00	3.00	0.660	100.	0.109E+04	10.0	0.260
7	1.500	0	95.00	3.00	0.660	100.	0.109E+04	10.0	0.260
8	1.650	0	95.00	3.00	0.660	100.	0.109E+04	10.0	0.260
9	2.200	0	95.00	3.00	0.660	100.	0.109E+04	10.0	0.260
10	2.400	0							

Branch 5 has 17 xsects & routes 1.00 of flow at JNCT 2 To JNCT 3

Grd	R Mile	IOUT	Disch	A1	A2	AO	DF	W1	W2
1	7.200	0	197.0	3.20	0.660	100.	0.202E+04	13.0	0.260
2	7.350	0	197.0	3.20	0.660	100.	0.202E+04	13.0	0.260
3	7.450	0	197.0	3.20	0.660	100.	0.202E+04	13.0	0.260
4	7.600	0	197.0	3.20	0.660	100.	0.202E+04	13.0	0.260
5	7.900	0	197.0	3.20	0.660	100.	0.202E+04	13.0	0.260
6	8.100	0	166.0	3.20	0.660	100.	0.202E+04	13.0	0.260
7	8.300	0	166.0	3.20	0.660	100.	0.202E+04	13.0	0.260
8	8.700	0	166.0	3.40	0.660	120.	0.290E+04	13.0	0.260
9	8.900	0	166.0	3.40	0.660	120.	0.290E+04	13.0	0.260
10	9.000	0	166.0	3.40	0.660	120.	0.290E+04	13.0	0.260
11	9.200	0	166.0	3.40	0.660	120.	0.290E+04	13.0	0.260
12	9.400	0	166.0	3.40	0.660	120.	0.290E+04	13.0	0.260
13	9.800	0	166.0	3.40	0.660	120.	0.290E+04	13.0	0.260
14	9.900	0	166.0	3.40	0.660	120.	0.290E+04	13.0	0.260
15	10.10	0	166.0	3.40	0.660	120.	0.290E+04	13.0	0.260
16	10.30	0	166.0	3.40	0.660	120.	0.290E+04	13.0	0.260
17	10.50	0							

Branch 6 has 18 xsects & routes 1.00 of flow at JNCT 3 To JNCT 4

Grd	R Mile	IOUT	Disch	A1	A2	AO	DF	W1	W2
1	10.50	0	166.0	3.40	0.660	120.	0.290E+04	13.0	0.260
2	10.85	0	166.0	3.40	0.660	120.	0.290E+04	13.0	0.260
3	11.00	0	164.0	3.40	0.660	120.	0.290E+04	13.0	0.260
4	11.60	0	164.0	3.40	0.660	120.	0.290E+04	13.0	0.260
5	11.75	0	164.0	3.40	0.660	120.	0.290E+04	13.0	0.260
6	11.90	0	164.0	3.40	0.660	120.	0.290E+04	13.0	0.260
7	12.20	0	164.0	3.40	0.660	120.	0.290E+04	13.0	0.260
8	12.50	1	164.0	3.40	0.660	150.	0.251E+04	14.0	0.260
9	12.85	0	164.0	3.40	0.660	150.	0.251E+04	14.0	0.260
10	13.05	0	164.0	3.40	0.660	150.	0.251E+04	14.0	0.260
11	13.25	0	164.0	3.40	0.660	150.	0.251E+04	14.0	0.260
12	13.40	0	164.0	3.40	0.660	150.	0.251E+04	14.0	0.260
13	13.60	0	164.0	3.40	0.660	150.	0.251E+04	14.0	0.260
14	13.70	0	164.0	3.40	0.660	150.	0.251E+04	14.0	0.260
15	13.80	0	164.0	3.40	0.660	150.	0.251E+04	14.0	0.260
16	14.10	0	164.0	3.40	0.660	150.	0.251E+04	14.0	0.260
17	14.30	0	164.0	3.40	0.660	150.	0.251E+04	14.0	0.260
18	14.50	0							

Appendix E. Tualatin River network (RM 63.9 to 38.4)—Continued

Branch 7 has 16 xsects & routes 1.00 of flow at JNCT 4 To JNCT 5

Grd	R Mile	IOUT	Disch	A1	A2	AO	DF	W1	W2
1	14.50	0	164.0	3.40	0.660	150.	0.251E+04	14.0	0.260
2	14.75	0	164.0	3.40	0.660	150.	0.251E+04	14.0	0.260
3	14.85	0	164.0	3.40	0.660	150.	0.251E+04	14.0	0.260
4	15.40	0	164.0	3.40	0.660	150.	0.251E+04	14.0	0.260
5	15.55	0	164.0	3.40	0.660	150.	0.251E+04	14.0	0.260
6	15.90	0	164.0	3.40	0.660	150.	0.251E+04	14.0	0.260
7	16.20	0	163.0	3.40	0.660	150.	0.251E+04	14.0	0.260
8	16.90	0	163.0	3.60	0.660	200.	0.288E+04	15.0	0.260
9	17.05	0	163.0	3.60	0.660	200.	0.288E+04	15.0	0.260
10	17.35	0	163.0	3.60	0.660	200.	0.288E+04	15.0	0.260
11	17.50	0	163.0	3.60	0.660	200.	0.288E+04	15.0	0.260
12	17.90	0	163.0	3.60	0.660	200.	0.288E+04	15.0	0.260
13	18.40	0	163.0	3.60	0.660	200.	0.288E+04	15.0	0.260
14	18.55	0	163.0	3.60	0.660	200.	0.288E+04	15.0	0.260
15	18.70	0	163.0	3.60	0.660	200.	0.288E+04	15.0	0.260
16	19.10	0							

Branch 8 has 6 xsects & routes 1.00 of flow at JNCT 9 To JNCT 5

Grd	R Mile	IOUT	Disch	A1	A2	AO	DF	W1	W2
1	0.0000E+00	0	73.00	3.00	0.660	120.	0.109E+04	10.0	0.260
2	0.4000	0	73.00	3.00	0.660	120.	0.109E+04	10.0	0.260
3	0.7000	0	73.00	3.00	0.660	120.	0.109E+04	10.0	0.260
4	1.100	0	73.00	3.00	0.660	120.	0.109E+04	10.0	0.260
5	1.700	0	72.00	3.00	0.660	120.	0.109E+04	10.0	0.260
6	2.100	0							

Branch 9 has 19 xsects & routes 1.00 of flow at JNCT 5 To JNCT 10

Grd	R Mile	IOUT	Disch	A1	A2	AO	DF	W1	W2
1	19.10	0	236.0	3.80	0.660	210.	0.529E+04	17.0	0.260
2	19.80	0	236.0	3.80	0.660	210.	0.529E+04	17.0	0.260
3	20.00	0	236.0	3.80	0.660	210.	0.529E+04	17.0	0.260
4	20.20	0	236.0	3.80	0.660	210.	0.529E+04	17.0	0.260
5	20.40	0	236.0	3.80	0.660	210.	0.529E+04	17.0	0.260
6	20.85	0	236.0	3.80	0.660	210.	0.529E+04	17.0	0.260
7	21.20	0	236.0	3.80	0.660	210.	0.858E+04	17.0	0.260
8	21.40	0	236.0	3.80	0.660	210.	0.858E+04	17.0	0.260
9	22.00	0	236.0	3.80	0.660	210.	0.858E+04	17.0	0.260
10	22.40	0	234.0	3.80	0.660	210.	0.858E+04	17.0	0.260
11	22.90	0	234.0	3.80	0.660	210.	0.858E+04	17.0	0.260
12	23.30	0	234.0	3.80	0.660	210.	0.858E+04	17.0	0.260
13	23.50	0	234.0	3.80	0.660	210.	0.858E+04	17.0	0.260
14	23.90	0	234.0	3.80	0.660	210.	0.858E+04	17.0	0.260
15	24.15	0	234.0	3.80	0.660	210.	0.858E+04	17.0	0.260
16	24.40	0	234.0	3.80	0.660	210.	0.858E+04	17.0	0.260
17	24.90	0	234.0	3.80	0.660	210.	0.858E+04	17.0	0.260
18	25.10	1	234.0	3.80	0.660	210.	0.858E+04	17.0	0.260
19	25.50	0							

APPENDIX F

BLTM.IN PARAMETER FILE FOR BLTM

Appendix F. Tualatin River network (RM 63.9 to 38.4)

HEADER 1	9	5	10272	1	0	02	48	0	1
HEADER 2	0.50	0.10							
LABEL	1	TEMP	1						

BRANCH 1	12	0.10	6	1	10
-----------------	-----------	-------------	----------	----------	-----------

GRID	1	0.000	0	10.15
GRID	2	0.150	0	10.15
GRID	3	0.400	0	10.15
GRID	4	0.900	0	10.15
GRID	5	1.400	0	10.15
GRID	6	1.650	0	10.15
GRID	7	1.900	0	10.15
GRID	8	2.000	0	10.15
GRID	9	2.400	0	10.25
GRID	10	2.900	0	10.50
GRID	11	3.400	0	10.75
GRID	12	3.900	0	

BRANCH 2	12	0.10	7	1	10
-----------------	-----------	-------------	----------	----------	-----------

GRID	1	0.000	0	6.78
GRID	2	0.300	0	7.00
GRID	3	0.900	0	7.10
GRID	4	1.500	0	7.20
GRID	5	1.800	0	7.30
GRID	6	2.300	0	7.40
GRID	7	2.800	0	7.50
GRID	8	3.100	0	7.60
GRID	9	3.400	0	7.70
GRID	10	4.000	0	7.80
GRID	11	4.300	0	7.90
GRID	12	4.800	0	

BRANCH 3	13	0.10	1	2	10
-----------------	-----------	-------------	----------	----------	-----------

GRID	1	3.900	0	11.00
GRID	2	4.300	0	11.25
GRID	3	4.550	0	11.50
GRID	4	4.800	0	11.75
GRID	5	5.000	1	12.42
GRID	6	5.400	0	12.42
GRID	7	5.600	0	12.42
GRID	8	5.900	0	12.42
GRID	9	6.200	0	12.42
GRID	10	6.400	0	12.42
GRID	11	6.650	0	12.42
GRID	12	6.900	0	12.42
GRID	13	7.200	0	

Appendix F. Tualatin River network (RM 63.9 to 38.4)—Continued

BRANCH	4	10	0.10	8	2	10
GRID	1	0.000	0	11.04		
GRID	2	0.200	0	11.00		
GRID	3	0.400	0	11.00		
GRID	4	0.700	0	11.00		
GRID	5	1.100	0	11.00		
GRID	6	1.200	0	11.00		
GRID	7	1.500	0	11.00		
GRID	8	1.650	0	11.00		
GRID	9	2.200	0	11.00		
GRID	10	2.400	0			

BRANCH	5	17	0.10	2	3	15
GRID	1	7.200	0	12.42		
GRID	2	7.350	0	12.42		
GRID	3	7.450	0	12.42		
GRID	4	7.600	0	12.42		
GRID	5	7.900	0	12.42		
GRID	6	8.100	0	12.42		
GRID	7	8.300	0	12.42		
GRID	8	8.700	0	12.42		
GRID	9	8.900	0	12.42		
GRID	10	9.000	0	12.42		
GRID	11	9.200	0	12.42		
GRID	12	9.400	0	12.42		
GRID	13	9.800	0	12.42		
GRID	14	9.900	0	12.42		
GRID	15	10.100	0	12.42		
GRID	16	10.300	0	12.42		
GRID	17	10.500	0			

BRANCH	6	18	0.10	3	4	15
GRID	1	10.500	0	12.42		
GRID	2	10.850	0	12.25		
GRID	3	11.000	0	12.00		
GRID	4	11.600	0	11.75		
GRID	5	11.750	0	11.50		
GRID	6	11.900	0	11.25		
GRID	7	12.200	0	11.00		
GRID	8	12.500	1	10.96		
GRID	9	12.850	0	11.00		
GRID	10	13.050	0	11.00		
GRID	11	13.250	0	11.00		
GRID	12	13.400	0	11.00		
GRID	13	13.600	0	11.00		
GRID	14	13.700	0	11.00		
GRID	15	13.800	0	11.00		
GRID	16	14.100	0	11.00		
GRID	17	14.300	0	11.00		
GRID	18	14.500	0			

Appendix F. Tualatin River network (RM 63.9 to 38.4)—Continued

BRANCH	7	16	0.10	4	5	15
GRID	1	14.500	0	11.00		
GRID	2	14.750	0	11.25		
GRID	3	14.850	0	11.50		
GRID	4	15.400	0	11.50		
GRID	5	15.550	0	11.50		
GRID	6	15.900	0	11.50		
GRID	7	16.200	0	11.50		
GRID	8	16.900	0	11.50		
GRID	9	17.050	0	11.50		
GRID	10	17.350	0	11.50		
GRID	11	17.500	0	11.50		
GRID	12	17.900	0	11.50		
GRID	13	18.400	0	11.50		
GRID	14	18.550	0	11.50		
GRID	15	18.700	0	11.50		
GRID	16	19.100	0			

BRANCH	8	6	0.10	9	5	5
GRID	1	0.000	0	11.99		
GRID	2	0.400	0	11.80		
GRID	3	0.700	0	11.70		
GRID	4	1.100	0	11.60		
GRID	5	1.700	0	11.50		
GRID	6	2.100	0			

BRANCH	9	19	0.10	5	10	15
GRID	1	19.100	0	11.50		
GRID	2	19.800	0	11.50		
GRID	3	20.000	0	11.50		
GRID	4	20.200	0	11.50		
GRID	5	20.400	0	11.50		
GRID	6	20.850	0	11.50		
GRID	7	21.200	0	11.50		
GRID	8	21.400	0	11.50		
GRID	9	22.000	0	11.50		
GRID	10	22.400	0	11.50		
GRID	11	22.900	0	11.50		
GRID	12	23.300	0	11.50		
GRID	13	23.500	0	11.50		
GRID	14	23.900	0	11.50		
GRID	15	24.150	0	11.50		
GRID	16	24.400	0	11.50		
GRID	17	24.900	0	11.75		
GRID	18	25.100	1	11.75		
GRID	19	25.500	0			

APPENDIX G

CE-QUAL-W2 MODEL GRID DIMENSIONS

REFERENCE: S.A. Rounds and others, U.S. Geological Survey, unpub. data, 1995

Table G1. Lengths, widths, and depths of the cells in the model grid. Segments 1 and 155 are boundary segments. Layers 1 and 16 are boundary layers. Cells in boundary segments or layers have zero widths. The river bottom is marked by cells with zero widths. To illustrate the change in elevation of the river bottom with river mile, cells with widths of zero are shaded. Elevations of each layer, noted in the header, are relative to the National Geodetic Vertical Datum (NGVD) of 1929

Segment Number	Upstream River Mile	Down-stream River Mile	Length (feet)	Width of Cell (feet)														
				Layer 2	Layer 3	Layer 4	Layer 5	Layer 6	Layer 7	Layer 8	Layer 9	Layer 10	Layer 11	Layer 12	Layer 13	Layer 14	Layer 15	
				120–110 feet	110–105 feet	105–102 feet	102–100 feet	100–98 feet	98–96 feet	96–94 feet	94–92 feet	92–90 feet	90–88 feet	88–86 feet	86–84 feet	84–82 feet	82–80 feet	
2	38.40	38.12	1,478	110	75	60	20	0	0	0	0	0	0	0	0	0	0	0
3	38.12	37.84	1,478	110	75	60	20	0	0	0	0	0	0	0	0	0	0	0
4	37.84	37.56	1,478	110	75	60	20	0	0	0	0	0	0	0	0	0	0	0
5	37.56	37.28	1,478	110	75	60	20	0	0	0	0	0	0	0	0	0	0	0
6	37.28	37.00	1,478	110	75	60	20	0	0	0	0	0	0	0	0	0	0	0
7	37.00	36.72	1,478	120	75	60	30	0	0	0	0	0	0	0	0	0	0	0
8	36.72	36.44	1,478	120	85	70	40	10	0	0	0	0	0	0	0	0	0	0
9	36.44	36.16	1,478	120	85	70	40	10	0	0	0	0	0	0	0	0	0	0
10	36.16	35.88	1,478	130	85	70	50	35	0	0	0	0	0	0	0	0	0	0
11	35.88	35.60	1,478	130	85	70	50	30	0	0	0	0	0	0	0	0	0	0
12	35.60	35.32	1,478	130	85	70	40	15	0	0	0	0	0	0	0	0	0	0
13	35.32	35.04	1,478	140	90	70	20	0	0	0	0	0	0	0	0	0	0	0
14	35.04	34.76	1,478	140	100	70	20	0	0	0	0	0	0	0	0	0	0	0
15	34.76	34.48	1,478	140	100	80	55	30	10	0	0	0	0	0	0	0	0	0
16	34.48	34.20	1,478	150	110	80	60	40	25	0	0	0	0	0	0	0	0	0
17	34.20	33.92	1,478	150	110	80	60	35	20	0	0	0	0	0	0	0	0	0
18	33.92	33.64	1,478	150	110	90	60	45	20	0	0	0	0	0	0	0	0	0
19	33.64	33.36	1,478	160	110	90	50	15	0	0	0	0	0	0	0	0	0	0
20	33.36	33.08	1,478	170	120	90	45	20	0	0	0	0	0	0	0	0	0	0
21	33.08	32.80	1,478	170	120	90	40	20	0	0	0	0	0	0	0	0	0	0
22	32.80	32.52	1,478	170	120	90	60	30	10	0	0	0	0	0	0	0	0	0
23	32.52	32.24	1,478	170	130	90	67	45	20	0	0	0	0	0	0	0	0	0
24	32.24	31.96	1,478	170	130	100	75	50	30	0	0	0	0	0	0	0	0	0
25	31.96	31.68	1,478	170	130	100	83	50	30	0	0	0	0	0	0	0	0	0
26	31.68	31.40	1,478	170	130	100	83	50	30	0	0	0	0	0	0	0	0	0
27	31.40	31.12	1,478	170	130	100	83	50	30	0	0	0	0	0	0	0	0	0
28	31.12	30.84	1,478	170	130	100	86	64	30	0	0	0	0	0	0	0	0	0
29	30.84	30.56	1,478	170	130	100	86	64	20	0	0	0	0	0	0	0	0	0
30	30.56	30.28	1,478	180	140	100	75	49	20	0	0	0	0	0	0	0	0	0
31	30.28	30.00	1,478	180	140	100	75	49	20	0	0	0	0	0	0	0	0	0
32	30.00	29.72	1,478	200	140	100	74	49	20	0	0	0	0	0	0	0	0	0

Table G1. Lengths, widths, and depths of the cells in the model grid. Segments 1 and 155 are boundary segments. Layers 1 and 16 are boundary layers. Cells in boundary segments or layers have zero widths. The river bottom is marked by cells with zero widths. To illustrate the change in elevation of the river bottom with river mile, cells with widths of zero are shaded. Elevations of each layer, noted in the header, are relative to the National Geodetic Vertical Datum (NGVD) of 1929—Continued

Segment Number	Upstream River Mile	Down-stream River Mile	Length (feet)	Width of Cell (feet)														
				Layer 2	Layer 3	Layer 4	Layer 5	Layer 6	Layer 7	Layer 8	Layer 9	Layer 10	Layer 11	Layer 12	Layer 13	Layer 14	Layer 15	
				120–110 feet	110–105 feet	105–102 feet	102–100 feet	100–98 feet	98–96 feet	96–94 feet	94–92 feet	92–90 feet	90–88 feet	88–86 feet	86–84 feet	84–82 feet	82–80 feet	
33	29.72	29.44	1,478	200	140	110	93	75	57	20	10	0	0	0	0	0	0	
34	29.44	29.16	1,478	220	140	110	97	85	71	58	46	20	0	0	0	0	0	
35	29.16	28.88	1,478	220	140	110	96	81	68	54	20	10	0	0	0	0	0	
36	28.88	28.60	1,478	220	140	110	97	85	72	58	47	20	0	0	0	0	0	
37	28.60	28.32	1,478	220	140	110	97	85	72	58	47	20	0	0	0	0	0	
38	28.32	28.16	820	220	140	110	98	89	75	62	52	30	0	0	0	0	0	
39	28.16	28.04	658	220	140	110	92	75	59	0	0	0	0	0	0	0	0	
40	28.04	27.76	1,478	220	140	110	98	87	75	63	52	30	0	0	0	0	0	
41	27.76	27.48	1,478	220	140	110	96	81	68	54	20	10	0	0	0	0	0	
42	27.48	27.20	1,478	220	140	110	97	85	72	58	47	20	0	0	0	0	0	
43	27.20	26.97	1,216	250	150	110	99	88	78	67	56	45	0	0	0	0	0	
44	26.97	26.92	262	250	150	110	92	79	62	26	0	0	0	0	0	0	0	
45	26.92	26.78	739	280	160	120	105	89	79	66	56	46	0	0	0	0	0	
46	26.78	26.64	739	280	160	120	105	89	79	66	56	46	0	0	0	0	0	
47	26.64	26.36	1,478	280	160	120	105	89	74	59	46	0	0	0	0	0	0	
48	26.36	26.22	739	280	160	120	108	96	85	73	61	49	20	0	0	0	0	
49	26.22	26.08	739	280	160	120	108	96	85	73	61	49	20	0	0	0	0	
50	26.08	25.80	1,478	280	160	120	107	94	82	0	0	0	0	0	0	0	0	
51	25.80	25.66	739	280	160	120	108	96	85	73	61	49	20	0	0	0	0	
52	25.66	25.52	739	280	160	120	108	96	85	73	61	49	20	0	0	0	0	
53	25.52	25.24	1,478	280	160	120	105	89	74	59	46	0	0	0	0	0	0	
54	25.24	24.96	1,478	280	160	120	106	92	78	64	50	0	0	0	0	0	0	
55	24.96	24.85	559	280	160	120	106	92	78	64	50	39	0	0	0	0	0	
56	24.85	24.75	559	280	160	120	106	92	78	64	50	39	0	0	0	0	0	
57	24.75	24.68	361	280	160	120	105	82	59	0	0	0	0	0	0	0	0	
58	24.68	24.40	1,478	280	160	120	106	92	78	64	50	0	0	0	0	0	0	
59	24.40	24.12	1,478	280	160	120	107	94	82	69	56	22	0	0	0	0	0	
60	24.12	23.98	739	280	160	120	109	98	87	76	65	54	22	0	0	0	0	
61	23.98	23.84	739	280	160	120	109	98	87	76	65	54	22	0	0	0	0	
62	23.84	23.56	1,478	280	160	120	107	94	82	69	56	22	0	0	0	0	0	
63	23.56	23.28	1,478	280	160	120	106	92	78	64	50	0	0	0	0	0	0	

Table G1. Lengths, widths, and depths of the cells in the model grid. Segments 1 and 155 are boundary segments. Layers 1 and 16 are boundary layers. Cells in boundary segments or layers have zero widths. The river bottom is marked by cells with zero widths. To illustrate the change in elevation of the river bottom with river mile, cells with widths of zero are shaded. Elevations of each layer, noted in the header, are relative to the National Geodetic Vertical Datum (NGVD) of 1929—Continued

Segment Number	Upstream River Mile	Down-stream River Mile	Length (feet)	Width of Cell (feet)														
				Layer 2	Layer 3	Layer 4	Layer 5	Layer 6	Layer 7	Layer 8	Layer 9	Layer 10	Layer 11	Layer 12	Layer 13	Layer 14	Layer 15	
				120–110 feet	110–105 feet	105–102 feet	102–100 feet	100–98 feet	98–96 feet	96–94 feet	94–92 feet	92–90 feet	90–88 feet	88–86 feet	86–84 feet	84–82 feet	82–80 feet	
64	23.28	23.18	525	279	161	121	82	0	0	0	0	0	0	0	0	0	0	0
65	23.18	23.12	312	459	328	230	213	197	180	164	148	131	115	98	82	0	0	0
66	23.12	23.06	312	459	328	230	213	197	180	164	148	131	115	98	82	0	0	0
67	23.06	23.00	330	279	161	121	98	66	0	0	0	0	0	0	0	0	0	0
68	23.00	22.72	1,478	280	160	120	106	92	78	64	50	0	0	0	0	0	0	0
69	22.72	22.44	1,478	280	160	120	107	94	82	69	56	22	0	0	0	0	0	0
70	22.44	22.16	1,478	280	160	120	107	94	82	69	56	22	0	0	0	0	0	0
71	22.16	21.88	1,478	280	160	120	106	92	78	64	50	0	0	0	0	0	0	0
72	21.88	21.76	625	280	160	120	105	92	79	66	49	0	0	0	0	0	0	0
73	21.76	21.60	853	280	160	120	98	66	0	0	0	0	0	0	0	0	0	0
74	21.60	21.32	1,478	280	160	120	105	89	74	59	22	0	0	0	0	0	0	0
75	21.32	21.18	739	280	160	120	109	98	87	76	65	54	22	0	0	0	0	0
76	21.18	21.04	739	280	160	120	109	98	87	76	65	54	22	0	0	0	0	0
77	21.04	20.76	1,478	280	160	120	108	96	85	73	61	49	0	0	0	0	0	0
78	20.76	20.62	739	280	160	120	109	98	87	76	65	54	22	0	0	0	0	0
79	20.62	20.48	739	280	160	120	109	98	87	76	65	54	22	0	0	0	0	0
80	20.48	20.20	1,478	280	160	120	108	96	85	73	61	49	0	0	0	0	0	0
81	20.20	19.92	1,478	280	160	120	106	92	78	64	50	0	0	0	0	0	0	0
82	19.92	19.64	1,478	280	160	120	107	94	82	69	56	22	0	0	0	0	0	0
83	19.64	19.36	1,478	280	160	120	107	94	82	69	56	22	0	0	0	0	0	0
84	19.36	19.08	1,478	300	170	130	116	102	88	75	61	23	0	0	0	0	0	0
85	19.08	18.80	1,478	320	180	140	127	114	102	89	76	63	25	0	0	0	0	0
86	18.80	18.52	1,478	320	180	140	127	114	102	89	76	63	25	0	0	0	0	0
87	18.52	18.24	1,478	320	180	140	127	114	102	89	76	63	25	0	0	0	0	0
88	18.24	18.10	739	320	180	140	129	118	106	95	84	73	62	25	0	0	0	0
89	18.10	17.96	739	320	180	140	129	118	106	95	84	73	62	25	0	0	0	0
90	17.96	17.68	1,478	320	180	140	127	114	102	89	76	63	25	0	0	0	0	0
91	17.68	17.40	1,478	320	180	140	126	112	99	85	71	57	0	0	0	0	0	0
92	17.40	17.12	1,478	320	180	140	128	116	104	92	80	68	56	0	0	0	0	0
93	17.12	16.88	1,282	320	180	140	128	115	102	89	75	62	26	0	0	0	0	0
94	16.88	16.84	197	320	180	140	115	98	0	0	0	0	0	0	0	0	0	0

Table G1. Lengths, widths, and depths of the cells in the model grid. Segments 1 and 155 are boundary segments. Layers 1 and 16 are boundary layers. Cells in boundary segments or layers have zero widths. The river bottom is marked by cells with zero widths. To illustrate the change in elevation of the river bottom with river mile, cells with widths of zero are shaded. Elevations of each layer, noted in the header, are relative to the National Geodetic Vertical Datum (NGVD) of 1929—Continued

Segment Number	Upstream River Mile	Down-stream River Mile	Length (feet)	Width of Cell (feet)														
				Layer 2	Layer 3	Layer 4	Layer 5	Layer 6	Layer 7	Layer 8	Layer 9	Layer 10	Layer 11	Layer 12	Layer 13	Layer 14	Layer 15	
				120–110 feet	110–105 feet	105–102 feet	102–100 feet	100–98 feet	98–96 feet	96–94 feet	94–92 feet	92–90 feet	90–88 feet	88–86 feet	86–84 feet	84–82 feet	82–80 feet	
95	16.84	16.56	1,478	320	180	140	127	114	102	89	76	63	25	0	0	0	0	
96	16.56	16.32	1,282	320	180	140	127	114	102	89	76	63	56	0	0	0	0	
97	16.32	16.28	197	320	180	140	118	105	82	33	0	0	0	0	0	0	0	
98	16.28	16.00	1,478	320	180	140	127	114	102	89	76	63	25	0	0	0	0	
99	16.00	15.72	1,478	320	180	140	129	118	106	95	84	73	62	25	0	0	0	
100	15.72	15.44	1,478	320	180	140	129	118	106	95	84	73	62	25	0	0	0	
101	15.44	15.16	1,478	320	180	140	126	112	99	85	71	57	0	0	0	0	0	
102	15.16	14.88	1,478	320	180	140	125	110	95	80	65	25	0	0	0	0	0	
103	14.88	14.60	1,478	320	180	140	126	112	99	85	71	57	0	0	0	0	0	
104	14.60	14.32	1,478	320	180	140	129	118	106	95	84	73	62	25	0	0	0	
105	14.32	14.04	1,478	320	180	140	129	118	106	95	84	73	62	25	0	0	0	
106	14.04	13.76	1,478	320	180	140	128	116	104	92	80	68	56	0	0	0	0	
107	13.76	13.48	1,478	320	180	140	127	114	102	89	76	63	25	0	0	0	0	
108	13.48	13.20	1,478	350	190	150	137	124	112	99	86	73	60	0	0	0	0	
109	13.20	13.16	197	350	190	150	125	98	75	0	0	0	0	0	0	0	0	
110	13.16	12.92	1,282	350	190	150	132	115	98	80	63	52	0	0	0	0	0	
111	12.92	12.64	1,478	350	190	150	135	120	106	91	76	61	0	0	0	0	0	
112	12.64	12.50	739	350	190	150	138	126	114	102	90	78	66	27	0	0	0	
113	12.50	12.36	739	350	190	150	138	126	114	102	90	78	66	27	0	0	0	
114	12.36	12.08	1,478	350	190	150	136	123	109	95	81	68	27	0	0	0	0	
115	12.08	11.99	459	350	190	150	131	112	85	52	0	0	0	0	0	0	0	
116	11.99	11.80	1,019	350	190	150	141	128	118	105	92	79	66	52	0	0	0	
117	11.80	11.52	1,478	350	190	150	139	127	116	105	94	82	71	60	0	0	0	
118	11.52	11.24	1,478	350	190	150	138	126	114	102	90	78	66	27	0	0	0	
119	11.24	10.96	1,478	350	190	150	138	126	114	102	90	78	66	27	0	0	0	
120	10.96	10.82	739	350	190	150	139	129	118	107	97	86	75	65	27	0	0	
121	10.82	10.68	739	350	190	150	139	129	118	107	97	86	75	65	27	0	0	
122	10.68	10.40	1,478	360	200	160	147	134	122	109	96	83	70	29	0	0	0	
123	10.40	10.12	1,478	400	220	170	150	130	111	91	71	0	0	0	0	0	0	
124	10.12	9.84	1,478	400	220	170	160	20	0	0	0	0	0	0	0	0	0	
125	9.84	9.56	1,478	400	220	170	146	122	97	73	0	0	0	0	0	0	0	

Table G1. Lengths, widths, and depths of the cells in the model grid. Segments 1 and 155 are boundary segments. Layers 1 and 16 are boundary layers. Cells in boundary segments or layers have zero widths. The river bottom is marked by cells with zero widths. To illustrate the change in elevation of the river bottom with river mile, cells with widths of zero are shaded. Elevations of each layer, noted in the header, are relative to the National Geodetic Vertical Datum (NGVD) of 1929—Continued

Segment Number	Upstream River Mile	Down-stream River Mile	Length (feet)	Width of Cell (feet)													
				Layer 2	Layer 3	Layer 4	Layer 5	Layer 6	Layer 7	Layer 8	Layer 9	Layer 10	Layer 11	Layer 12	Layer 13	Layer 14	Layer 15
				120–110 feet	110–105 feet	105–102 feet	102–100 feet	100–98 feet	98–96 feet	96–94 feet	94–92 feet	92–90 feet	90–88 feet	88–86 feet	86–84 feet	84–82 feet	82–80 feet
126	9.56	9.28	1,478	400	220	170	146	122	97	73	0	0	0	0	0	0	0
127	9.28	9.00	1,478	400	220	170	150	130	111	91	71	0	0	0	0	0	0
128	9.00	8.72	1,478	400	220	170	150	130	111	91	71	0	0	0	0	0	0
129	8.72	8.44	1,478	400	220	170	148	126	105	83	31	0	0	0	0	0	0
130	8.44	8.16	1,478	400	220	170	150	130	111	91	71	0	0	0	0	0	0
131	8.16	7.88	1,478	400	220	170	148	126	105	83	31	0	0	0	0	0	0
132	7.88	7.60	1,478	400	220	170	143	116	88	31	0	0	0	0	0	0	0
133	7.60	7.32	1,478	400	220	170	143	116	89	31	0	0	0	0	0	0	0
134	7.32	7.18	739	400	220	170	152	134	116	98	79	30	0	0	0	0	0
135	7.18	7.04	739	400	220	170	152	134	116	98	79	30	0	0	0	0	0
136	7.04	6.76	1,478	400	220	170	150	130	111	91	71	0	0	0	0	0	0
137	6.76	6.48	1,478	400	230	180	159	138	117	96	75	0	0	0	0	0	0
138	6.48	6.20	1,478	400	240	190	175	160	144	129	114	99	84	34	0	0	0
139	6.20	6.06	739	400	240	190	178	166	154	142	130	118	106	94	82	35	0
140	6.06	5.92	739	400	240	190	178	166	154	142	130	118	106	94	82	35	0
141	5.92	5.69	1,216	400	240	190	173	155	138	120	103	86	72	0	0	0	0
142	5.69	5.64	262	400	240	190	171	144	112	69	0	0	0	0	0	0	0
143	5.64	5.50	739	400	240	190	177	164	151	138	125	112	99	86	73	0	0
144	5.50	5.36	739	400	240	190	177	164	151	138	125	112	99	86	73	0	0
145	5.36	5.31	262	400	240	190	167	131	115	98	72	0	0	0	0	0	0
146	5.31	5.08	1,216	400	240	190	174	158	142	126	110	94	78	33	0	0	0
147	5.08	4.94	739	400	240	190	178	166	154	142	130	118	106	94	82	35	0
148	4.94	4.80	739	400	240	190	178	166	154	142	130	118	106	94	82	35	0
149	4.80	4.52	1,478	400	240	190	177	164	151	138	125	112	99	86	73	0	0
150	4.52	4.24	1,478	400	240	190	177	164	151	138	125	112	99	86	73	0	0
151	4.24	4.10	739	400	240	190	179	169	158	148	137	127	116	105	95	84	74
152	4.10	3.96	739	400	240	190	179	169	158	148	137	127	116	105	95	84	74
153	3.96	3.68	1,478	500	240	190	176	161	147	133	119	104	90	76	0	0	0
154	3.68	3.40	1,478	500	240	190	163	136	109	82	0	0	0	0	0	0	0

APPENDIX H

**TABLES OF THE PERCENTAGE OF TIME THE 7-DAY MOVING AVERAGE
OF DAILY MAXIMUM SIMULATED MAY THROUGH OCTOBER 1994
WATER TEMPERATURES EXCEEDS 17.8 DEGREES CELSIUS ALONG
THE MAIN STEM OF THE TUALATIN RIVER FOR EACH SCENARIO**

Table H1. Percentage of time the 7-day moving average of daily maximum simulated May 1994 water temperatures exceeds 17.8 degrees Celsius along the main stem of the Tualatin River for each scenario

River mile	Scenario:										
	1	2	3	4a	4b	5	6	7	8	9	10
63.90	0.0	0.0	0.0	0.0	0.0	0.0	0.0	0.0	0.0	0.0	0.0
63.75	0.0	0.0	0.0	0.0	0.0	0.0	0.0	0.0	0.0	0.0	0.0
63.50	0.0	0.0	0.0	0.0	0.0	0.0	0.0	0.0	0.0	0.0	0.0
63.00	0.0	0.0	0.0	0.0	0.0	0.0	0.0	0.0	0.0	0.0	0.0
62.50	0.0	0.0	0.0	0.0	0.0	0.0	0.0	0.0	0.0	0.0	0.0
62.25	0.0	0.0	0.0	0.0	0.0	0.0	0.0	0.0	0.0	0.0	0.0
62.00	0.0	0.0	0.0	0.0	0.0	0.0	0.0	0.0	0.0	0.0	0.0
61.90	0.0	0.0	0.0	0.0	0.0	0.0	0.0	0.0	0.0	0.0	0.0
61.50	0.0	0.0	0.0	0.0	0.0	0.0	0.0	0.0	0.0	0.0	0.0
61.00	0.0	0.0	0.0	0.0	0.0	0.0	0.0	0.0	0.0	0.0	0.0
60.50	0.0	0.0	0.0	0.0	0.0	0.0	0.0	0.0	0.0	0.0	0.0
60.00	0.0	0.0	0.0	0.0	0.0	0.0	0.0	0.0	0.0	0.0	0.0
59.60	0.0	0.0	0.0	0.0	0.0	0.0	0.0	0.0	0.0	0.0	0.0
59.35	0.0	0.0	0.0	0.0	0.0	0.0	0.0	0.0	0.0	0.0	0.0
59.10	0.0	0.0	0.0	0.0	0.0	0.0	0.0	0.0	0.0	0.0	0.0
58.90	0.0	0.0	0.0	0.0	0.0	0.0	0.0	0.0	0.0	0.0	0.0
58.50	0.0	0.0	0.0	0.0	0.0	0.0	0.0	0.0	0.0	0.0	0.0
58.30	0.0	0.0	0.0	0.0	0.0	0.0	0.0	0.0	0.0	0.0	0.0
58.00	0.0	0.0	0.0	0.0	0.0	0.0	0.0	0.0	0.0	0.0	0.0
57.70	0.0	0.0	0.0	0.0	0.0	0.0	0.0	0.0	0.0	0.0	0.0
57.50	0.0	0.0	0.0	0.0	0.0	0.0	0.0	0.0	0.0	0.0	0.0
57.25	0.0	0.0	0.0	0.0	0.0	0.0	0.0	0.0	0.0	0.0	0.0
57.00	0.0	0.0	0.0	0.0	0.0	0.0	0.0	0.0	0.0	0.0	0.0
56.70	0.0	0.0	0.0	0.0	0.0	0.0	0.0	0.0	0.0	0.0	0.0
56.55	0.0	0.0	0.0	0.0	0.0	0.0	0.0	0.0	0.0	0.0	0.0
56.45	0.0	0.0	0.0	0.0	0.0	0.0	0.0	0.0	0.0	0.0	0.0
56.30	0.0	0.0	0.0	0.0	0.0	0.0	0.0	0.0	0.0	0.0	0.0
56.00	0.0	0.0	0.0	0.0	0.0	0.0	0.0	0.0	0.0	0.0	0.0
55.80	0.0	0.0	0.0	0.0	0.0	0.0	0.0	0.0	0.0	0.0	0.0
55.60	0.0	0.0	0.0	0.0	0.0	0.0	0.0	0.0	0.0	0.0	0.0
55.20	0.0	0.0	0.0	0.0	0.0	0.0	0.0	0.0	0.0	0.0	0.0
55.00	0.0	0.0	0.0	0.0	0.0	0.0	0.0	0.0	0.0	0.0	0.0
54.90	0.0	0.0	0.0	0.0	0.0	0.0	0.0	0.0	0.0	0.0	0.0
54.70	0.0	0.0	0.0	0.0	0.0	0.0	0.0	0.0	0.0	0.0	0.0
54.50	0.0	0.0	0.0	0.0	0.0	0.0	0.0	0.0	0.0	0.0	0.0
54.10	0.0	0.0	0.0	0.0	0.0	0.0	0.0	0.0	0.0	0.0	0.0
54.00	0.0	0.0	0.0	0.0	0.0	0.0	0.0	0.0	0.0	0.0	0.0
53.80	0.0	0.0	0.0	0.0	0.0	0.0	0.0	0.0	0.0	0.0	0.0
53.60	0.0	0.0	0.0	0.0	0.0	0.0	0.0	0.0	0.0	0.0	0.0
53.40	0.0	0.0	0.0	0.0	0.0	0.0	0.0	0.0	0.0	0.0	0.0
53.05	0.0	0.0	0.0	0.0	0.0	0.0	0.0	0.0	0.0	0.0	0.0
52.90	0.0	0.0	0.0	0.0	0.0	0.0	0.0	0.0	0.0	0.0	0.0
52.30	0.0	0.0	0.0	0.0	0.0	0.0	0.0	0.0	0.0	0.0	0.0
52.15	0.0	0.0	0.0	0.0	0.0	0.0	0.0	0.0	0.0	0.0	0.0
52.00	0.0	0.0	0.0	0.0	0.0	0.0	0.0	0.0	0.0	0.0	0.0
51.70	0.0	0.0	0.0	0.0	0.0	0.0	0.0	0.0	0.0	0.0	0.0
51.40	0.0	0.0	0.0	0.0	0.0	0.0	0.0	0.0	0.0	0.0	0.0
51.05	0.0	0.0	0.0	0.0	0.0	0.0	0.0	0.0	0.0	0.0	0.0
50.85	0.0	0.0	0.0	0.0	0.0	0.0	0.0	0.0	0.0	0.0	0.0
50.65	0.0	0.0	0.0	0.0	0.0	0.0	0.0	0.0	0.0	0.0	0.0

Table H1. Percentage of time the 7-day moving average of daily maximum simulated May 1994 water temperatures exceeds 17.8 degrees Celsius along the main stem of the Tualatin River for each scenario—Continued

River mile	Scenario:										
	1	2	3	4a	4b	5	6	7	8	9	10
50.50	0.0	0.0	0.0	0.0	0.0	0.0	0.0	0.0	0.0	0.0	0.0
50.30	0.0	0.0	0.0	0.0	0.0	0.0	0.0	0.0	0.0	0.0	0.0
50.20	0.0	0.0	0.0	0.0	0.0	0.0	0.0	0.0	0.0	0.0	0.0
50.10	0.0	0.0	0.0	0.0	0.0	0.0	0.0	0.0	0.0	0.0	0.0
49.80	0.0	0.0	0.0	0.0	0.0	0.0	0.0	0.0	0.0	0.0	0.0
49.60	0.0	0.0	0.0	0.0	0.0	0.0	0.0	0.0	0.0	0.0	0.0
49.40	0.0	0.0	0.0	0.0	0.0	0.0	0.0	0.0	0.0	0.0	0.0
49.15	0.0	0.0	0.0	0.0	0.0	0.0	0.0	0.0	0.0	0.0	0.0
49.05	0.0	0.0	0.0	0.0	0.0	0.0	0.0	0.0	0.0	0.0	0.0
48.50	0.0	0.0	0.0	0.0	0.0	0.0	0.0	0.0	0.0	0.0	0.0
48.35	0.0	0.0	0.0	0.0	0.0	0.0	0.0	0.0	0.0	0.0	0.0
48.00	0.0	0.0	0.0	0.0	0.0	0.0	0.0	0.0	0.0	0.0	0.0
47.70	0.0	0.0	0.0	0.0	0.0	0.0	0.0	0.0	0.0	0.0	0.0
47.00	0.0	0.0	0.0	0.0	0.0	0.0	0.0	0.0	0.0	0.0	0.0
46.85	0.0	0.0	0.0	0.0	0.0	0.0	0.0	0.0	0.0	0.0	0.0
46.55	0.0	0.0	0.0	0.0	0.0	0.0	0.0	0.0	0.0	0.0	0.0
46.40	0.0	0.0	0.0	0.0	0.0	0.0	0.0	0.0	0.0	0.0	0.0
46.00	0.0	0.0	0.0	0.0	0.0	0.0	0.0	0.0	0.0	0.0	0.0
45.50	0.0	0.0	0.0	0.0	0.0	0.0	0.0	0.0	0.0	0.0	0.0
45.35	0.0	0.0	0.0	0.0	0.0	0.0	0.0	0.0	0.0	0.0	0.0
45.20	0.0	0.0	0.0	0.0	0.0	0.0	0.0	0.0	0.0	0.0	0.0
44.80	0.0	0.0	0.0	0.0	0.0	0.0	0.0	0.0	0.0	0.0	0.0
44.10	0.0	0.0	0.0	0.0	0.0	0.0	0.0	0.0	0.0	0.0	0.0
43.90	0.0	0.0	0.0	0.0	0.0	0.0	0.0	0.0	0.0	0.0	0.0
43.70	0.0	0.0	0.0	0.0	0.0	0.0	0.0	0.0	0.0	0.0	0.0
43.50	0.0	0.0	0.0	0.0	0.0	0.0	0.0	0.0	0.0	0.0	0.0
43.05	0.0	0.0	0.0	0.0	0.0	0.0	0.0	0.0	0.0	0.0	0.0
42.70	0.0	0.0	0.0	0.0	0.0	0.0	0.0	0.0	0.0	0.0	0.0
42.50	0.0	0.0	0.0	0.0	0.0	0.0	0.0	0.0	0.0	0.0	0.0
41.90	0.0	0.0	0.0	0.0	0.0	0.0	0.0	0.0	0.0	0.0	0.0
41.50	0.0	0.0	0.0	0.0	0.0	0.0	0.0	0.0	0.0	0.0	0.0
41.00	0.0	0.0	0.0	0.0	0.0	0.0	0.0	0.0	0.0	0.0	0.0
40.60	0.0	0.0	0.0	0.0	0.0	0.0	0.0	0.0	0.0	0.0	0.0
40.40	0.0	0.0	0.0	0.0	0.0	0.0	0.0	0.0	0.0	0.0	0.0
40.00	0.0	0.0	0.0	0.0	0.0	0.0	0.0	0.0	0.0	0.0	0.0
39.75	0.0	0.0	0.0	0.0	0.0	0.0	0.0	0.0	0.0	0.0	0.0
39.50	0.0	0.0	0.0	0.0	0.0	0.0	0.0	0.0	0.0	0.0	0.0
39.00	0.0	0.0	0.0	0.0	0.0	0.0	0.0	0.0	0.0	0.0	0.0
38.80	0.0	0.0	0.0	0.0	0.0	0.0	0.0	0.0	0.0	0.0	0.0
38.40	0.0	0.0	0.0	0.0	0.0	0.0	0.0	0.0	0.0	0.0	0.0
37.98	0.0	0.0	0.0	0.0	0.0	0.0	0.0	0.0	0.0	0.0	0.0
37.70	0.0	0.0	0.0	3.2	0.0	0.0	0.0	0.0	0.0	0.0	0.0
37.42	0.0	0.0	0.0	3.2	0.0	0.0	0.0	0.0	0.0	0.0	0.0
37.14	0.0	0.0	0.0	3.2	0.0	0.0	0.0	0.0	0.0	0.0	0.0
36.86	0.0	0.0	0.0	12.9	0.0	0.0	0.0	0.0	0.0	0.0	0.0
36.58	0.0	0.0	0.0	16.1	0.0	0.0	0.0	0.0	0.0	0.0	0.0
36.30	0.0	0.0	0.0	19.4	0.0	0.0	0.0	0.0	0.0	0.0	0.0
36.02	0.0	0.0	0.0	25.8	0.0	0.0	0.0	0.0	0.0	0.0	0.0
35.74	0.0	0.0	0.0	25.8	0.0	0.0	0.0	0.0	0.0	0.0	0.0
35.46	0.0	0.0	0.0	25.8	0.0	0.0	0.0	0.0	0.0	0.0	0.0

Table H1. Percentage of time the 7-day moving average of daily maximum simulated May 1994 water temperatures exceeds 17.8 degrees Celsius along the main stem of the Tualatin River for each scenario—Continued

River mile	Scenario:										
	1	2	3	4a	4b	5	6	7	8	9	10
35.18	0.0	0.0	0.0	25.8	0.0	0.0	0.0	0.0	0.0	0.0	0.0
34.90	0.0	0.0	0.0	32.3	0.0	0.0	0.0	0.0	0.0	0.0	0.0
34.62	0.0	0.0	0.0	32.3	0.0	0.0	0.0	0.0	0.0	0.0	0.0
34.34	0.0	0.0	0.0	35.5	0.0	0.0	0.0	0.0	0.0	0.0	0.0
34.06	0.0	0.0	0.0	38.7	0.0	0.0	0.0	0.0	0.0	0.0	0.0
33.78	0.0	0.0	0.0	38.7	0.0	0.0	0.0	0.0	0.0	0.0	0.0
33.50	0.0	0.0	0.0	41.9	0.0	0.0	0.0	0.0	0.0	0.0	0.0
33.22	0.0	0.0	0.0	45.2	0.0	0.0	0.0	0.0	0.0	0.0	0.0
32.94	0.0	0.0	0.0	45.2	0.0	0.0	0.0	0.0	0.0	0.0	0.0
32.66	0.0	0.0	0.0	45.2	0.0	0.0	0.0	0.0	0.0	0.0	0.0
32.38	0.0	0.0	0.0	45.2	0.0	0.0	0.0	0.0	0.0	0.0	0.0
32.10	0.0	0.0	0.0	45.2	0.0	0.0	0.0	0.0	0.0	0.0	0.0
31.82	0.0	0.0	0.0	48.4	0.0	0.0	0.0	0.0	0.0	0.0	0.0
31.54	0.0	0.0	0.0	48.4	0.0	0.0	0.0	0.0	0.0	0.0	0.0
31.26	0.0	0.0	0.0	48.4	0.0	0.0	0.0	0.0	0.0	0.0	0.0
30.98	0.0	0.0	0.0	48.4	0.0	0.0	0.0	0.0	0.0	0.0	0.0
30.70	0.0	0.0	0.0	48.4	0.0	0.0	0.0	0.0	0.0	0.0	0.0
30.42	0.0	0.0	0.0	48.4	0.0	0.0	0.0	0.0	0.0	0.0	0.0
30.14	0.0	0.0	0.0	48.4	0.0	0.0	0.0	0.0	0.0	0.0	0.0
29.86	0.0	0.0	0.0	41.9	0.0	0.0	0.0	0.0	0.0	0.0	0.0
29.58	0.0	0.0	0.0	41.9	0.0	0.0	0.0	0.0	0.0	0.0	0.0
29.30	0.0	0.0	0.0	41.9	0.0	0.0	0.0	0.0	0.0	0.0	0.0
29.02	0.0	0.0	0.0	41.9	0.0	0.0	0.0	0.0	0.0	0.0	0.0
28.74	0.0	0.0	0.0	41.9	0.0	0.0	0.0	0.0	0.0	0.0	0.0
28.46	0.0	0.0	0.0	45.2	0.0	0.0	0.0	0.0	0.0	0.0	0.0
28.24	0.0	0.0	0.0	29.0	0.0	0.0	0.0	0.0	0.0	0.0	0.0
28.10	0.0	0.0	0.0	35.5	0.0	0.0	0.0	0.0	0.0	0.0	0.0
27.90	0.0	0.0	0.0	35.5	0.0	0.0	0.0	0.0	0.0	0.0	0.0
27.62	0.0	0.0	0.0	35.5	0.0	0.0	0.0	0.0	0.0	0.0	0.0
27.34	0.0	0.0	0.0	41.9	0.0	0.0	0.0	0.0	0.0	0.0	0.0
27.09	0.0	0.0	0.0	38.7	0.0	0.0	0.0	0.0	0.0	0.0	0.0
26.95	0.0	0.0	0.0	38.7	0.0	0.0	0.0	0.0	0.0	0.0	0.0
26.85	0.0	0.0	0.0	41.9	0.0	0.0	0.0	0.0	0.0	0.0	0.0
26.71	0.0	0.0	0.0	41.9	0.0	0.0	0.0	0.0	0.0	0.0	0.0
26.50	0.0	0.0	0.0	41.9	0.0	0.0	0.0	0.0	0.0	0.0	0.0
26.29	0.0	0.0	0.0	54.8	0.0	0.0	0.0	0.0	0.0	0.0	0.0
26.15	0.0	0.0	0.0	45.2	0.0	0.0	0.0	0.0	0.0	0.0	0.0
25.94	0.0	0.0	0.0	54.8	0.0	0.0	0.0	0.0	0.0	0.0	0.0
25.73	0.0	0.0	0.0	54.8	0.0	0.0	0.0	0.0	0.0	0.0	0.0
25.59	0.0	0.0	0.0	54.8	0.0	0.0	0.0	0.0	0.0	0.0	0.0
25.38	0.0	0.0	0.0	54.8	0.0	0.0	0.0	0.0	0.0	0.0	0.0
25.10	0.0	0.0	0.0	54.8	0.0	0.0	0.0	0.0	0.0	0.0	0.0
24.91	0.0	0.0	0.0	54.8	0.0	0.0	0.0	0.0	0.0	0.0	0.0
24.80	0.0	0.0	0.0	48.4	0.0	0.0	0.0	0.0	0.0	0.0	0.0
24.72	0.0	0.0	0.0	54.8	0.0	0.0	0.0	0.0	0.0	0.0	0.0
24.54	0.0	0.0	0.0	54.8	0.0	0.0	0.0	0.0	0.0	0.0	0.0
24.26	0.0	0.0	0.0	54.8	0.0	0.0	0.0	0.0	0.0	0.0	0.0
24.05	3.2	3.2	0.0	54.8	0.0	3.2	0.0	0.0	0.0	0.0	0.0
23.91	0.0	0.0	0.0	54.8	0.0	0.0	0.0	0.0	0.0	0.0	0.0
23.70	6.5	6.5	0.0	54.8	0.0	6.5	0.0	6.5	0.0	0.0	0.0

Table H1. Percentage of time the 7-day moving average of daily maximum simulated May 1994 water temperatures exceeds 17.8 degrees Celsius along the main stem of the Tualatin River for each scenario—Continued

River mile	Scenario:										
	1	2	3	4a	4b	5	6	7	8	9	10
23.42	0.0	0.0	0.0	45.2	0.0	0.0	0.0	0.0	0.0	0.0	0.0
23.23	0.0	0.0	0.0	54.8	0.0	0.0	0.0	0.0	0.0	0.0	0.0
23.15	0.0	0.0	0.0	48.4	0.0	0.0	0.0	0.0	0.0	0.0	0.0
23.09	0.0	0.0	0.0	48.4	0.0	0.0	0.0	0.0	0.0	0.0	0.0
23.03	0.0	0.0	0.0	54.8	0.0	0.0	0.0	0.0	0.0	0.0	0.0
22.86	0.0	0.0	0.0	54.8	0.0	0.0	0.0	0.0	0.0	0.0	0.0
22.58	0.0	0.0	0.0	54.8	0.0	0.0	0.0	0.0	0.0	0.0	0.0
22.30	0.0	0.0	0.0	54.8	0.0	0.0	0.0	0.0	0.0	0.0	0.0
22.02	3.2	3.2	0.0	58.1	0.0	3.2	0.0	0.0	0.0	0.0	0.0
21.82	0.0	0.0	0.0	51.6	0.0	0.0	0.0	0.0	0.0	0.0	0.0
21.68	0.0	0.0	0.0	58.1	0.0	0.0	0.0	0.0	0.0	0.0	0.0
21.46	0.0	0.0	0.0	58.1	0.0	0.0	0.0	0.0	0.0	0.0	0.0
21.25	0.0	0.0	0.0	58.1	0.0	0.0	0.0	0.0	0.0	0.0	0.0
21.11	0.0	0.0	0.0	58.1	0.0	0.0	0.0	0.0	0.0	0.0	0.0
20.90	0.0	0.0	0.0	58.1	0.0	0.0	0.0	0.0	0.0	0.0	0.0
20.69	0.0	0.0	0.0	58.1	0.0	0.0	0.0	0.0	0.0	0.0	0.0
20.55	0.0	0.0	0.0	58.1	0.0	0.0	0.0	0.0	0.0	0.0	0.0
20.34	0.0	0.0	0.0	58.1	0.0	0.0	0.0	0.0	0.0	0.0	0.0
20.06	0.0	0.0	0.0	58.1	0.0	0.0	0.0	0.0	0.0	0.0	0.0
19.78	0.0	0.0	0.0	58.1	0.0	0.0	0.0	0.0	0.0	0.0	0.0
19.50	0.0	0.0	0.0	58.1	0.0	0.0	0.0	0.0	0.0	0.0	0.0
19.22	0.0	0.0	0.0	58.1	0.0	0.0	0.0	0.0	0.0	0.0	0.0
18.94	0.0	0.0	0.0	61.3	0.0	0.0	0.0	0.0	0.0	0.0	0.0
18.66	0.0	0.0	0.0	61.3	0.0	0.0	0.0	0.0	0.0	0.0	0.0
18.38	0.0	0.0	0.0	61.3	0.0	0.0	0.0	0.0	0.0	0.0	0.0
18.17	0.0	3.2	0.0	64.5	0.0	3.2	0.0	0.0	0.0	0.0	0.0
18.03	0.0	0.0	0.0	61.3	0.0	0.0	0.0	0.0	0.0	0.0	0.0
17.82	0.0	0.0	0.0	61.3	0.0	0.0	0.0	0.0	0.0	0.0	0.0
17.54	0.0	0.0	0.0	61.3	0.0	0.0	0.0	0.0	0.0	0.0	0.0
17.26	3.2	3.2	0.0	64.5	0.0	6.5	0.0	0.0	0.0	0.0	0.0
17.00	0.0	0.0	0.0	54.8	0.0	0.0	0.0	0.0	0.0	0.0	0.0
16.86	0.0	0.0	0.0	61.3	0.0	0.0	0.0	0.0	0.0	0.0	0.0
16.70	0.0	0.0	0.0	61.3	0.0	0.0	0.0	0.0	0.0	0.0	0.0
16.44	0.0	0.0	0.0	61.3	0.0	0.0	0.0	0.0	0.0	0.0	0.0
16.30	0.0	0.0	0.0	61.3	0.0	0.0	0.0	0.0	0.0	0.0	0.0
16.14	0.0	0.0	0.0	61.3	0.0	0.0	0.0	0.0	0.0	0.0	0.0
15.86	0.0	0.0	0.0	64.5	0.0	0.0	0.0	0.0	0.0	0.0	0.0
15.58	0.0	0.0	0.0	67.7	0.0	0.0	0.0	0.0	0.0	0.0	0.0
15.30	0.0	0.0	0.0	61.3	0.0	0.0	0.0	0.0	0.0	0.0	0.0
15.02	0.0	0.0	0.0	61.3	0.0	0.0	0.0	0.0	0.0	0.0	0.0
14.74	0.0	0.0	0.0	67.7	0.0	0.0	0.0	0.0	0.0	0.0	0.0
14.46	0.0	0.0	0.0	67.7	0.0	0.0	0.0	0.0	0.0	0.0	0.0
14.18	0.0	0.0	0.0	67.7	0.0	0.0	0.0	0.0	0.0	0.0	0.0
13.90	0.0	0.0	0.0	67.7	0.0	0.0	0.0	0.0	0.0	0.0	0.0
13.62	0.0	0.0	0.0	67.7	0.0	0.0	0.0	0.0	0.0	0.0	0.0
13.34	0.0	0.0	0.0	61.3	0.0	0.0	0.0	0.0	0.0	0.0	0.0
13.18	0.0	0.0	0.0	64.5	0.0	0.0	0.0	0.0	0.0	0.0	0.0
13.04	0.0	0.0	0.0	64.5	0.0	0.0	0.0	0.0	0.0	0.0	0.0
12.78	0.0	0.0	0.0	67.7	0.0	0.0	0.0	0.0	0.0	0.0	0.0
12.57	0.0	0.0	0.0	67.7	0.0	0.0	0.0	0.0	0.0	0.0	0.0

Table H1. Percentage of time the 7-day moving average of daily maximum simulated May 1994 water temperatures exceeds 17.8 degrees Celsius along the main stem of the Tualatin River for each scenario—Continued

River mile	Scenario:										
	1	2	3	4a	4b	5	6	7	8	9	10
12.43	0.0	0.0	0.0	71.0	0.0	0.0	0.0	0.0	0.0	0.0	0.0
12.22	0.0	0.0	0.0	67.7	0.0	0.0	0.0	0.0	0.0	0.0	0.0
12.04	0.0	0.0	0.0	67.7	0.0	0.0	0.0	0.0	0.0	0.0	0.0
11.90	0.0	0.0	0.0	71.0	0.0	0.0	0.0	0.0	0.0	0.0	0.0
11.66	0.0	0.0	0.0	74.2	0.0	0.0	0.0	0.0	0.0	0.0	0.0
11.38	0.0	0.0	0.0	77.4	0.0	0.0	0.0	0.0	0.0	0.0	0.0
11.10	0.0	0.0	0.0	77.4	0.0	0.0	0.0	0.0	0.0	0.0	0.0
10.89	0.0	0.0	0.0	77.4	0.0	0.0	0.0	0.0	0.0	0.0	0.0
10.75	0.0	0.0	0.0	77.4	0.0	0.0	0.0	0.0	0.0	0.0	0.0
10.54	0.0	0.0	0.0	77.4	0.0	0.0	0.0	0.0	0.0	0.0	0.0
10.26	0.0	0.0	0.0	64.5	0.0	0.0	0.0	0.0	0.0	0.0	0.0
9.98	0.0	0.0	0.0	77.4	0.0	0.0	0.0	0.0	0.0	0.0	0.0
9.70	0.0	0.0	0.0	77.4	0.0	0.0	0.0	0.0	0.0	0.0	0.0
9.42	0.0	0.0	0.0	77.4	0.0	0.0	0.0	0.0	0.0	0.0	0.0
9.14	0.0	0.0	0.0	77.4	0.0	0.0	0.0	0.0	0.0	0.0	0.0
8.86	0.0	0.0	0.0	77.4	0.0	3.2	0.0	0.0	0.0	0.0	0.0
8.58	3.2	3.2	0.0	77.4	0.0	9.7	0.0	0.0	0.0	0.0	0.0
8.30	6.5	6.5	0.0	77.4	0.0	16.1	0.0	0.0	0.0	3.2	0.0
8.02	0.0	0.0	0.0	77.4	0.0	19.4	0.0	0.0	0.0	6.5	0.0
7.74	16.1	16.1	0.0	80.6	0.0	19.4	0.0	0.0	0.0	6.5	0.0
7.46	16.1	16.1	0.0	80.6	0.0	29.0	0.0	0.0	0.0	19.4	0.0
7.25	6.5	6.5	0.0	80.6	0.0	29.0	0.0	0.0	0.0	22.6	0.0
7.11	6.5	6.5	0.0	80.6	0.0	32.3	0.0	0.0	0.0	29.0	0.0
6.90	6.5	6.5	0.0	80.6	0.0	35.5	0.0	0.0	0.0	29.0	0.0
6.62	6.5	6.5	0.0	80.6	0.0	41.9	0.0	0.0	0.0	29.0	0.0
6.34	6.5	6.5	0.0	80.6	0.0	41.9	0.0	0.0	0.0	29.0	0.0
6.13	6.5	3.2	0.0	80.6	0.0	41.9	0.0	0.0	0.0	22.6	0.0
5.99	3.2	3.2	0.0	80.6	0.0	16.1	0.0	0.0	0.0	0.0	0.0
5.81	0.0	0.0	0.0	77.4	0.0	32.3	0.0	0.0	0.0	12.9	0.0
5.67	0.0	0.0	0.0	77.4	0.0	25.8	0.0	0.0	0.0	3.2	0.0
5.57	0.0	0.0	0.0	77.4	0.0	9.7	0.0	0.0	0.0	0.0	0.0
5.43	0.0	0.0	0.0	77.4	0.0	22.6	0.0	0.0	0.0	0.0	0.0
5.34	0.0	0.0	0.0	77.4	0.0	6.5	0.0	0.0	0.0	0.0	0.0
5.20	0.0	0.0	0.0	77.4	0.0	6.5	0.0	0.0	0.0	0.0	0.0
5.01	0.0	0.0	0.0	77.4	0.0	6.5	0.0	0.0	0.0	0.0	0.0
4.87	0.0	0.0	0.0	77.4	0.0	0.0	0.0	0.0	0.0	0.0	0.0
4.66	0.0	0.0	0.0	77.4	0.0	0.0	0.0	0.0	0.0	0.0	0.0
4.38	0.0	0.0	0.0	80.6	0.0	0.0	0.0	0.0	0.0	0.0	0.0
4.17	0.0	0.0	0.0	80.6	0.0	0.0	0.0	0.0	0.0	0.0	0.0
4.03	0.0	0.0	0.0	80.6	0.0	0.0	0.0	0.0	0.0	0.0	0.0
3.82	0.0	0.0	0.0	77.4	0.0	0.0	0.0	0.0	0.0	0.0	0.0

Table H2. Percentage of time the 7-day moving average of daily maximum simulated June 1994 water temperatures exceeds 17.8 degrees Celsius along the main stem of the Tualatin River for each scenario

River mile	Scenario:										
	1	2	3	4a	4b	5	6	7	8	9	10
63.90	0.0	0.0	0.0	0.0	0.0	0.0	0.0	0.0	0.0	0.0	0.0
63.75	0.0	0.0	0.0	0.0	0.0	0.0	0.0	0.0	0.0	0.0	0.0
63.50	0.0	0.0	0.0	0.0	0.0	0.0	0.0	0.0	0.0	0.0	0.0
63.00	0.0	0.0	0.0	0.0	0.0	0.0	0.0	0.0	0.0	0.0	0.0
62.50	0.0	0.0	0.0	0.0	0.0	0.0	0.0	0.0	0.0	0.0	0.0
62.25	0.0	0.0	0.0	0.0	0.0	0.0	0.0	0.0	0.0	0.0	0.0
62.00	0.0	0.0	0.0	0.0	0.0	0.0	0.0	0.0	0.0	0.0	0.0
61.90	0.0	0.0	0.0	0.0	0.0	0.0	0.0	0.0	0.0	0.0	0.0
61.50	0.0	0.0	0.0	0.0	0.0	0.0	0.0	0.0	0.0	0.0	0.0
61.00	0.0	0.0	0.0	0.0	0.0	0.0	0.0	0.0	0.0	0.0	0.0
60.50	0.0	0.0	0.0	0.0	0.0	0.0	0.0	0.0	0.0	0.0	0.0
60.00	0.0	0.0	0.0	0.0	0.0	0.0	0.0	0.0	0.0	0.0	0.0
59.60	0.0	0.0	0.0	0.0	0.0	0.0	0.0	0.0	0.0	0.0	0.0
59.35	0.0	0.0	0.0	0.0	0.0	0.0	0.0	0.0	0.0	0.0	0.0
59.10	0.0	0.0	0.0	0.0	0.0	0.0	0.0	0.0	0.0	0.0	0.0
58.90	0.0	0.0	0.0	0.0	0.0	0.0	0.0	0.0	0.0	0.0	0.0
58.50	0.0	0.0	0.0	0.0	0.0	0.0	0.0	0.0	0.0	0.0	0.0
58.30	0.0	0.0	0.0	0.0	0.0	0.0	0.0	0.0	0.0	0.0	0.0
58.00	0.0	0.0	0.0	0.0	0.0	0.0	0.0	0.0	0.0	0.0	0.0
57.70	0.0	0.0	0.0	0.0	0.0	0.0	0.0	0.0	0.0	0.0	0.0
57.50	0.0	0.0	0.0	0.0	0.0	0.0	0.0	0.0	0.0	0.0	0.0
57.25	0.0	0.0	0.0	0.0	0.0	0.0	0.0	0.0	0.0	0.0	0.0
57.00	0.0	0.0	0.0	0.0	0.0	0.0	0.0	0.0	0.0	0.0	0.0
56.70	0.0	0.0	0.0	0.0	0.0	0.0	0.0	0.0	0.0	0.0	0.0
56.55	0.0	0.0	0.0	0.0	0.0	0.0	0.0	0.0	0.0	0.0	0.0
56.45	0.0	0.0	0.0	0.0	0.0	0.0	0.0	0.0	0.0	0.0	0.0
56.30	0.0	0.0	0.0	0.0	0.0	0.0	0.0	0.0	0.0	0.0	0.0
56.00	0.0	0.0	0.0	0.0	0.0	0.0	0.0	0.0	0.0	0.0	0.0
55.80	0.0	0.0	0.0	0.0	0.0	0.0	0.0	0.0	0.0	0.0	0.0
55.60	0.0	0.0	0.0	0.0	0.0	0.0	0.0	0.0	0.0	0.0	0.0
55.20	0.0	0.0	0.0	0.0	0.0	0.0	0.0	0.0	0.0	0.0	0.0
55.00	0.0	0.0	0.0	0.0	0.0	0.0	0.0	0.0	0.0	0.0	0.0
54.90	0.0	0.0	0.0	0.0	0.0	0.0	0.0	0.0	0.0	0.0	0.0
54.70	0.0	0.0	0.0	0.0	0.0	0.0	0.0	0.0	0.0	0.0	0.0
54.50	0.0	0.0	0.0	0.0	0.0	0.0	0.0	0.0	0.0	0.0	0.0
54.10	0.0	0.0	0.0	0.0	0.0	0.0	0.0	0.0	0.0	0.0	0.0
54.00	0.0	0.0	0.0	0.0	0.0	0.0	0.0	0.0	0.0	0.0	0.0
53.80	0.0	0.0	0.0	0.0	0.0	0.0	0.0	0.0	0.0	0.0	0.0
53.60	0.0	0.0	0.0	0.0	0.0	0.0	0.0	0.0	0.0	0.0	0.0
53.40	0.0	0.0	0.0	0.0	0.0	0.0	0.0	0.0	0.0	0.0	0.0
53.05	0.0	0.0	0.0	0.0	0.0	0.0	0.0	0.0	0.0	0.0	0.0
52.90	0.0	0.0	0.0	0.0	0.0	0.0	0.0	0.0	0.0	0.0	0.0
52.30	0.0	0.0	0.0	0.0	0.0	0.0	0.0	0.0	0.0	0.0	0.0
52.15	0.0	0.0	0.0	0.0	0.0	0.0	0.0	0.0	0.0	0.0	0.0
52.00	0.0	0.0	0.0	0.0	0.0	0.0	0.0	0.0	0.0	0.0	0.0
51.70	0.0	0.0	0.0	0.0	0.0	0.0	0.0	0.0	0.0	0.0	0.0
51.40	0.0	0.0	0.0	0.0	0.0	0.0	0.0	0.0	0.0	0.0	0.0
51.05	0.0	0.0	0.0	0.0	0.0	0.0	0.0	0.0	0.0	0.0	0.0
50.85	0.0	0.0	0.0	0.0	0.0	0.0	0.0	0.0	0.0	0.0	0.0
50.65	0.0	0.0	0.0	0.0	0.0	0.0	0.0	0.0	0.0	0.0	0.0

Table H2. Percentage of time the 7-day moving average of daily maximum simulated June 1994 water temperatures exceeds 17.8 degrees Celsius along the main stem of the Tualatin River for each scenario—Continued

River mile	Scenario:										
	1	2	3	4a	4b	5	6	7	8	9	10
50.50	0.0	0.0	0.0	0.0	0.0	0.0	0.0	0.0	0.0	0.0	0.0
50.30	0.0	0.0	0.0	0.0	0.0	0.0	0.0	0.0	0.0	0.0	0.0
50.20	0.0	0.0	0.0	0.0	0.0	0.0	0.0	0.0	0.0	0.0	0.0
50.10	0.0	0.0	0.0	0.0	0.0	0.0	0.0	0.0	0.0	0.0	0.0
49.80	0.0	0.0	0.0	0.0	0.0	0.0	0.0	0.0	0.0	0.0	0.0
49.60	0.0	0.0	0.0	0.0	0.0	0.0	0.0	0.0	0.0	0.0	0.0
49.40	0.0	0.0	0.0	0.0	0.0	0.0	0.0	0.0	0.0	0.0	0.0
49.15	0.0	0.0	0.0	0.0	0.0	0.0	0.0	0.0	0.0	0.0	0.0
49.05	0.0	0.0	0.0	0.0	0.0	0.0	0.0	0.0	0.0	0.0	0.0
48.50	0.0	0.0	0.0	0.0	0.0	0.0	0.0	0.0	0.0	0.0	0.0
48.35	0.0	0.0	0.0	0.0	0.0	0.0	0.0	0.0	0.0	0.0	0.0
48.00	0.0	0.0	0.0	0.0	0.0	0.0	0.0	0.0	0.0	0.0	0.0
47.70	0.0	0.0	0.0	0.0	0.0	0.0	0.0	0.0	0.0	0.0	0.0
47.00	0.0	0.0	0.0	0.0	0.0	0.0	0.0	0.0	0.0	0.0	0.0
46.85	0.0	0.0	0.0	0.0	0.0	0.0	0.0	0.0	0.0	0.0	0.0
46.55	0.0	0.0	0.0	0.0	0.0	0.0	0.0	0.0	0.0	0.0	0.0
46.40	0.0	0.0	0.0	0.0	0.0	0.0	0.0	0.0	0.0	0.0	0.0
46.00	0.0	0.0	0.0	0.0	0.0	0.0	0.0	0.0	0.0	0.0	0.0
45.50	0.0	0.0	0.0	0.0	0.0	0.0	0.0	0.0	0.0	0.0	0.0
45.35	0.0	0.0	0.0	0.0	0.0	0.0	0.0	0.0	0.0	0.0	0.0
45.20	0.0	0.0	0.0	0.0	0.0	0.0	0.0	0.0	0.0	0.0	0.0
44.80	0.0	0.0	0.0	0.0	0.0	0.0	0.0	0.0	0.0	0.0	0.0
44.10	0.0	0.0	0.0	0.0	0.0	0.0	0.0	0.0	0.0	0.0	0.0
43.90	0.0	0.0	0.0	0.0	0.0	0.0	0.0	0.0	0.0	0.0	0.0
43.70	0.0	0.0	0.0	0.0	0.0	0.0	0.0	0.0	0.0	0.0	0.0
43.50	0.0	0.0	0.0	0.0	0.0	0.0	0.0	0.0	0.0	0.0	0.0
43.05	0.0	0.0	0.0	6.7	0.0	0.0	0.0	0.0	0.0	0.0	0.0
42.70	0.0	0.0	0.0	13.3	0.0	0.0	0.0	0.0	0.0	0.0	0.0
42.50	0.0	0.0	0.0	13.3	0.0	0.0	0.0	0.0	0.0	0.0	0.0
41.90	0.0	0.0	0.0	23.3	0.0	0.0	0.0	0.0	0.0	0.0	0.0
41.50	0.0	0.0	0.0	23.3	0.0	0.0	0.0	0.0	0.0	0.0	0.0
41.00	0.0	0.0	0.0	30.0	0.0	0.0	0.0	0.0	0.0	0.0	0.0
40.60	0.0	0.0	0.0	30.0	0.0	0.0	0.0	0.0	0.0	0.0	0.0
40.40	0.0	0.0	0.0	33.3	0.0	0.0	0.0	0.0	0.0	0.0	0.0
40.00	0.0	0.0	0.0	33.3	0.0	0.0	0.0	0.0	0.0	0.0	0.0
39.75	0.0	0.0	0.0	33.3	0.0	0.0	0.0	0.0	0.0	0.0	0.0
39.50	0.0	0.0	0.0	33.3	0.0	0.0	0.0	0.0	0.0	0.0	0.0
39.00	0.0	13.3	0.0	33.3	0.0	0.0	0.0	0.0	13.3	0.0	0.0
38.80	0.0	16.7	0.0	33.3	0.0	0.0	0.0	0.0	16.7	0.0	0.0
38.40	0.0	0.0	0.0	33.3	0.0	0.0	0.0	0.0	13.3	0.0	0.0
37.98	30.0	33.3	0.0	36.7	0.0	30.0	0.0	0.0	23.3	0.0	0.0
37.70	33.3	33.3	0.0	40.0	0.0	33.3	0.0	0.0	26.7	0.0	0.0
37.42	33.3	33.3	0.0	43.3	0.0	33.3	0.0	0.0	26.7	0.0	0.0
37.14	33.3	33.3	0.0	46.7	0.0	33.3	0.0	0.0	30.0	0.0	0.0
36.86	36.7	36.7	0.0	56.7	0.0	36.7	0.0	13.3	30.0	13.3	0.0
36.58	36.7	36.7	0.0	60.0	0.0	36.7	0.0	23.3	30.0	23.3	0.0
36.30	36.7	36.7	0.0	60.0	0.0	36.7	0.0	26.7	30.0	26.7	0.0
36.02	36.7	36.7	0.0	63.3	0.0	36.7	0.0	30.0	30.0	30.0	0.0
35.74	36.7	36.7	0.0	66.7	0.0	36.7	0.0	30.0	30.0	30.0	0.0
35.46	36.7	36.7	0.0	70.0	0.0	36.7	0.0	30.0	33.3	30.0	0.0

Table H2. Percentage of time the 7-day moving average of daily maximum simulated June 1994 water temperatures exceeds 17.8 degrees Celsius along the main stem of the Tualatin River for each scenario—Continued

River mile	Scenario:										
	1	2	3	4a	4b	5	6	7	8	9	10
35.18	36.7	36.7	0.0	73.3	0.0	36.7	0.0	30.0	33.3	30.0	0.0
34.90	36.7	36.7	0.0	73.3	0.0	36.7	0.0	33.3	33.3	33.3	0.0
34.62	36.7	36.7	0.0	76.7	0.0	36.7	0.0	33.3	33.3	33.3	0.0
34.34	36.7	36.7	0.0	76.7	0.0	36.7	0.0	33.3	33.3	33.3	0.0
34.06	36.7	36.7	0.0	80.0	0.0	36.7	0.0	33.3	33.3	33.3	0.0
33.78	36.7	36.7	0.0	80.0	0.0	36.7	0.0	33.3	33.3	33.3	0.0
33.50	36.7	36.7	0.0	80.0	0.0	36.7	0.0	33.3	33.3	33.3	0.0
33.22	36.7	36.7	0.0	80.0	0.0	36.7	0.0	33.3	33.3	33.3	0.0
32.94	36.7	36.7	0.0	80.0	0.0	36.7	0.0	33.3	33.3	33.3	0.0
32.66	36.7	36.7	0.0	80.0	0.0	36.7	0.0	33.3	33.3	33.3	0.0
32.38	36.7	36.7	0.0	80.0	0.0	36.7	0.0	33.3	33.3	33.3	0.0
32.10	36.7	36.7	0.0	83.3	0.0	36.7	0.0	33.3	33.3	33.3	0.0
31.82	36.7	36.7	0.0	83.3	0.0	36.7	0.0	36.7	33.3	36.7	0.0
31.54	36.7	36.7	0.0	83.3	0.0	36.7	0.0	36.7	33.3	36.7	0.0
31.26	36.7	36.7	0.0	83.3	0.0	40.0	0.0	36.7	36.7	36.7	0.0
30.98	36.7	36.7	0.0	83.3	0.0	36.7	0.0	36.7	33.3	36.7	0.0
30.70	36.7	36.7	0.0	80.0	0.0	40.0	0.0	36.7	36.7	36.7	0.0
30.42	36.7	40.0	0.0	80.0	0.0	40.0	0.0	36.7	36.7	36.7	0.0
30.14	40.0	40.0	0.0	80.0	0.0	40.0	0.0	36.7	36.7	36.7	0.0
29.86	40.0	40.0	0.0	76.7	0.0	40.0	0.0	36.7	36.7	36.7	0.0
29.58	40.0	40.0	0.0	76.7	0.0	40.0	0.0	36.7	36.7	36.7	0.0
29.30	40.0	40.0	0.0	76.7	6.7	40.0	0.0	36.7	36.7	36.7	0.0
29.02	40.0	40.0	3.3	83.3	26.7	40.0	13.3	36.7	36.7	36.7	0.0
28.74	40.0	40.0	3.3	76.7	30.0	40.0	10.0	36.7	36.7	36.7	0.0
28.46	46.7	46.7	13.3	86.7	30.0	50.0	10.0	36.7	36.7	36.7	0.0
28.24	36.7	36.7	0.0	70.0	0.0	36.7	0.0	33.3	33.3	33.3	0.0
28.10	36.7	36.7	0.0	76.7	10.0	36.7	0.0	33.3	33.3	33.3	0.0
27.90	36.7	36.7	0.0	76.7	0.0	36.7	0.0	33.3	33.3	33.3	0.0
27.62	36.7	36.7	20.0	76.7	26.7	36.7	0.0	36.7	36.7	33.3	0.0
27.34	36.7	36.7	23.3	76.7	30.0	36.7	20.0	36.7	36.7	36.7	0.0
27.09	36.7	36.7	13.3	76.7	26.7	36.7	0.0	33.3	33.3	33.3	0.0
26.95	36.7	36.7	13.3	76.7	26.7	36.7	0.0	33.3	33.3	33.3	0.0
26.85	36.7	36.7	20.0	76.7	30.0	36.7	10.0	36.7	36.7	36.7	0.0
26.71	36.7	36.7	23.3	76.7	30.0	36.7	20.0	36.7	36.7	36.7	0.0
26.50	36.7	36.7	23.3	80.0	30.0	36.7	23.3	36.7	36.7	36.7	10.0
26.29	40.0	40.0	26.7	93.3	33.3	40.0	30.0	36.7	36.7	36.7	23.3
26.15	36.7	36.7	20.0	76.7	30.0	36.7	20.0	33.3	33.3	33.3	0.0
25.94	40.0	40.0	23.3	90.0	30.0	40.0	26.7	36.7	36.7	36.7	20.0
25.73	40.0	40.0	26.7	93.3	33.3	40.0	30.0	36.7	36.7	36.7	26.7
25.59	40.0	40.0	26.7	93.3	33.3	40.0	30.0	36.7	36.7	36.7	26.7
25.38	46.7	46.7	26.7	96.7	33.3	46.7	30.0	36.7	36.7	40.0	26.7
25.10	46.7	46.7	26.7	93.3	33.3	46.7	30.0	36.7	36.7	36.7	26.7
24.91	50.0	50.0	30.0	100.0	33.3	53.3	33.3	40.0	40.0	46.7	30.0
24.80	40.0	36.7	26.7	86.7	30.0	46.7	30.0	36.7	36.7	36.7	23.3
24.72	46.7	46.7	26.7	96.7	33.3	46.7	30.0	36.7	36.7	36.7	26.7
24.54	46.7	46.7	26.7	96.7	33.3	46.7	30.0	36.7	36.7	36.7	26.7
24.26	50.0	50.0	30.0	100.0	33.3	50.0	30.0	36.7	36.7	36.7	30.0
24.05	53.3	53.3	30.0	100.0	33.3	53.3	33.3	46.7	40.0	46.7	30.0
23.91	46.7	50.0	26.7	96.7	33.3	50.0	30.0	36.7	36.7	36.7	26.7
23.70	50.0	53.3	30.0	100.0	33.3	53.3	33.3	46.7	40.0	46.7	30.0

Table H2. Percentage of time the 7-day moving average of daily maximum simulated June 1994 water temperatures exceeds 17.8 degrees Celsius along the main stem of the Tualatin River for each scenario—Continued

River mile	Scenario:										
	1	2	3	4a	4b	5	6	7	8	9	10
23.42	36.7	36.7	23.3	76.7	26.7	36.7	23.3	33.3	33.3	33.3	20.0
23.23	46.7	46.7	30.0	100.0	33.3	50.0	30.0	40.0	40.0	36.7	30.0
23.15	36.7	36.7	26.7	83.3	30.0	36.7	26.7	36.7	36.7	36.7	23.3
23.09	36.7	36.7	26.7	86.7	30.0	36.7	26.7	36.7	36.7	36.7	26.7
23.03	46.7	46.7	30.0	100.0	33.3	50.0	33.3	40.0	40.0	40.0	30.0
22.86	46.7	46.7	30.0	100.0	33.3	50.0	33.3	43.3	40.0	40.0	30.0
22.58	53.3	50.0	30.0	100.0	36.7	50.0	33.3	46.7	40.0	46.7	30.0
22.30	46.7	46.7	30.0	100.0	33.3	50.0	33.3	43.3	40.0	46.7	30.0
22.02	53.3	53.3	30.0	100.0	36.7	53.3	33.3	46.7	46.7	46.7	30.0
21.82	40.0	40.0	26.7	100.0	30.0	43.3	30.0	33.3	33.3	33.3	26.7
21.68	50.0	50.0	30.0	100.0	33.3	53.3	30.0	36.7	36.7	43.3	30.0
21.46	46.7	50.0	30.0	100.0	33.3	46.7	30.0	36.7	36.7	36.7	30.0
21.25	50.0	50.0	30.0	100.0	33.3	53.3	33.3	40.0	36.7	43.3	30.0
21.11	50.0	50.0	30.0	100.0	33.3	53.3	33.3	40.0	40.0	43.3	30.0
20.90	46.7	46.7	30.0	100.0	33.3	50.0	33.3	40.0	36.7	40.0	30.0
20.69	46.7	46.7	30.0	100.0	33.3	50.0	33.3	36.7	36.7	36.7	30.0
20.55	46.7	46.7	30.0	100.0	33.3	50.0	30.0	36.7	36.7	36.7	30.0
20.34	46.7	46.7	30.0	100.0	33.3	46.7	30.0	36.7	36.7	36.7	30.0
20.06	40.0	40.0	30.0	100.0	33.3	43.3	30.0	36.7	36.7	36.7	30.0
19.78	40.0	40.0	30.0	100.0	33.3	43.3	30.0	36.7	36.7	36.7	30.0
19.50	46.7	46.7	30.0	100.0	33.3	46.7	33.3	40.0	40.0	36.7	30.0
19.22	46.7	46.7	30.0	100.0	33.3	46.7	33.3	36.7	36.7	36.7	30.0
18.94	46.7	46.7	30.0	100.0	33.3	46.7	33.3	36.7	36.7	36.7	30.0
18.66	50.0	50.0	30.0	100.0	33.3	53.3	33.3	43.3	43.3	40.0	30.0
18.38	50.0	50.0	30.0	100.0	33.3	50.0	33.3	40.0	40.0	36.7	30.0
18.17	50.0	50.0	30.0	100.0	33.3	50.0	33.3	43.3	40.0	40.0	30.0
18.03	46.7	46.7	30.0	100.0	33.3	46.7	33.3	40.0	40.0	36.7	30.0
17.82	43.3	43.3	30.0	100.0	33.3	43.3	30.0	36.7	36.7	36.7	30.0
17.54	43.3	43.3	30.0	100.0	33.3	43.3	30.0	36.7	36.7	36.7	30.0
17.26	50.0	50.0	30.0	100.0	33.3	50.0	33.3	36.7	36.7	36.7	30.0
17.00	33.3	33.3	26.7	100.0	30.0	33.3	26.7	33.3	33.3	33.3	26.7
16.86	36.7	36.7	26.7	100.0	30.0	36.7	30.0	36.7	36.7	33.3	26.7
16.70	36.7	36.7	30.0	100.0	33.3	36.7	30.0	36.7	36.7	36.7	30.0
16.44	36.7	36.7	26.7	100.0	33.3	36.7	30.0	36.7	36.7	36.7	30.0
16.30	40.0	40.0	30.0	100.0	33.3	36.7	30.0	36.7	36.7	36.7	30.0
16.14	43.3	43.3	30.0	100.0	33.3	43.3	33.3	40.0	40.0	36.7	30.0
15.86	53.3	53.3	33.3	100.0	36.7	50.0	33.3	46.7	46.7	43.3	33.3
15.58	53.3	53.3	33.3	100.0	36.7	53.3	33.3	43.3	43.3	43.3	33.3
15.30	43.3	43.3	30.0	100.0	33.3	46.7	33.3	40.0	40.0	36.7	30.0
15.02	43.3	43.3	30.0	100.0	33.3	46.7	33.3	40.0	40.0	40.0	30.0
14.74	46.7	43.3	30.0	100.0	33.3	46.7	33.3	40.0	40.0	36.7	30.0
14.46	50.0	50.0	33.3	100.0	36.7	46.7	33.3	40.0	40.0	40.0	33.3
14.18	46.7	46.7	30.0	100.0	33.3	43.3	30.0	36.7	36.7	36.7	30.0
13.90	40.0	40.0	30.0	100.0	33.3	36.7	30.0	36.7	36.7	36.7	30.0
13.62	40.0	40.0	30.0	100.0	33.3	36.7	30.0	40.0	40.0	36.7	30.0
13.34	36.7	36.7	26.7	100.0	30.0	33.3	26.7	36.7	36.7	33.3	26.7
13.18	36.7	36.7	26.7	100.0	33.3	36.7	30.0	36.7	36.7	36.7	30.0
13.04	40.0	40.0	30.0	100.0	33.3	36.7	30.0	40.0	36.7	36.7	30.0
12.78	40.0	40.0	30.0	100.0	36.7	40.0	33.3	40.0	40.0	40.0	33.3
12.57	46.7	46.7	33.3	100.0	36.7	43.3	33.3	43.3	43.3	40.0	36.7

Table H2. Percentage of time the 7-day moving average of daily maximum simulated June 1994 water temperatures exceeds 17.8 degrees Celsius along the main stem of the Tualatin River for each scenario—Continued

River mile	Scenario:										
	1	2	3	4a	4b	5	6	7	8	9	10
12.43	53.3	53.3	33.3	100.0	40.0	53.3	36.7	46.7	46.7	43.3	33.3
12.22	40.0	40.0	30.0	100.0	36.7	40.0	33.3	40.0	40.0	40.0	30.0
12.04	43.3	43.3	30.0	100.0	36.7	40.0	33.3	40.0	40.0	40.0	33.3
11.90	53.3	53.3	33.3	100.0	36.7	50.0	36.7	46.7	43.3	43.3	33.3
11.66	53.3	53.3	33.3	100.0	40.0	53.3	36.7	46.7	46.7	46.7	36.7
11.38	53.3	53.3	33.3	100.0	40.0	53.3	36.7	46.7	46.7	46.7	36.7
11.10	53.3	53.3	33.3	100.0	40.0	53.3	36.7	46.7	43.3	40.0	36.7
10.89	53.3	56.7	33.3	100.0	40.0	53.3	36.7	50.0	50.0	43.3	33.3
10.75	50.0	53.3	33.3	100.0	36.7	50.0	33.3	43.3	43.3	40.0	33.3
10.54	50.0	46.7	30.0	100.0	36.7	43.3	33.3	40.0	40.0	40.0	33.3
10.26	33.3	33.3	23.3	100.0	30.0	33.3	26.7	33.3	33.3	33.3	26.7
9.98	53.3	53.3	33.3	100.0	40.0	53.3	36.7	46.7	46.7	53.3	36.7
9.70	53.3	53.3	36.7	100.0	40.0	66.7	36.7	53.3	53.3	53.3	40.0
9.42	66.7	66.7	36.7	100.0	50.0	70.0	40.0	60.0	56.7	60.0	40.0
9.14	70.0	70.0	40.0	100.0	60.0	70.0	43.3	60.0	60.0	66.7	40.0
8.86	70.0	70.0	40.0	100.0	60.0	70.0	40.0	60.0	60.0	70.0	40.0
8.58	70.0	70.0	40.0	100.0	60.0	73.3	43.3	66.7	60.0	70.0	40.0
8.30	70.0	70.0	43.3	100.0	60.0	73.3	43.3	63.3	60.0	70.0	40.0
8.02	70.0	70.0	43.3	100.0	56.7	73.3	40.0	56.7	56.7	73.3	36.7
7.74	73.3	70.0	43.3	100.0	60.0	73.3	46.7	56.7	56.7	73.3	40.0
7.46	70.0	70.0	46.7	100.0	56.7	76.7	40.0	56.7	56.7	73.3	40.0
7.25	70.0	70.0	46.7	100.0	56.7	80.0	40.0	56.7	56.7	73.3	40.0
7.11	70.0	70.0	56.7	100.0	56.7	83.3	43.3	60.0	60.0	80.0	40.0
6.90	73.3	73.3	56.7	100.0	60.0	83.3	43.3	63.3	63.3	83.3	40.0
6.62	66.7	66.7	53.3	100.0	50.0	83.3	40.0	56.7	63.3	73.3	40.0
6.34	70.0	70.0	60.0	100.0	60.0	83.3	43.3	66.7	70.0	73.3	40.0
6.13	73.3	73.3	60.0	100.0	63.3	80.0	53.3	66.7	70.0	73.3	40.0
5.99	73.3	73.3	40.0	100.0	63.3	73.3	53.3	66.7	70.0	56.7	40.0
5.81	70.0	70.0	50.0	100.0	56.7	73.3	40.0	56.7	56.7	66.7	40.0
5.67	70.0	70.0	40.0	100.0	56.7	73.3	40.0	63.3	56.7	60.0	40.0
5.57	70.0	70.0	40.0	100.0	56.7	70.0	40.0	56.7	56.7	56.7	40.0
5.43	70.0	70.0	40.0	100.0	56.7	73.3	40.0	56.7	56.7	60.0	40.0
5.34	70.0	70.0	40.0	100.0	60.0	70.0	50.0	66.7	66.7	56.7	43.3
5.20	70.0	70.0	40.0	100.0	66.7	66.7	50.0	66.7	66.7	56.7	46.7
5.01	73.3	73.3	40.0	100.0	66.7	66.7	56.7	66.7	66.7	56.7	46.7
4.87	73.3	70.0	40.0	100.0	63.3	66.7	53.3	63.3	66.7	60.0	40.0
4.66	70.0	70.0	40.0	100.0	56.7	66.7	46.7	63.3	66.7	66.7	40.0
4.38	70.0	70.0	40.0	100.0	56.7	70.0	46.7	56.7	66.7	66.7	40.0
4.17	70.0	70.0	40.0	100.0	56.7	70.0	46.7	56.7	63.3	66.7	36.7
4.03	70.0	70.0	36.7	100.0	56.7	60.0	46.7	56.7	63.3	53.3	36.7
3.82	60.0	63.3	36.7	100.0	43.3	66.7	40.0	50.0	53.3	56.7	36.7

Table H3. Percentage of time the 7-day moving average of daily maximum simulated July 1994 water temperatures exceeds 17.8 degrees Celsius along the main stem of the Tualatin River for each scenario

River mile	Scenario:										
	1	2	3	4a	4b	5	6	7	8	9	10
63.90	87.1	87.1	87.1	87.1	87.1	87.1	61.3	87.1	87.1	87.1	61.3
63.75	87.1	87.1	87.1	87.1	87.1	87.1	58.1	87.1	87.1	87.1	58.1
63.50	87.1	87.1	83.9	87.1	83.9	87.1	54.8	87.1	87.1	87.1	54.8
63.00	80.6	80.6	77.4	83.9	80.6	80.6	48.4	80.6	80.6	80.6	48.4
62.50	74.2	74.2	67.7	80.6	74.2	74.2	45.2	74.2	74.2	74.2	45.2
62.25	71.0	71.0	67.7	77.4	71.0	71.0	45.2	71.0	71.0	71.0	45.2
62.00	71.0	71.0	67.7	77.4	67.7	71.0	45.2	71.0	71.0	71.0	45.2
61.90	71.0	71.0	67.7	77.4	67.7	71.0	45.2	71.0	71.0	71.0	45.2
61.50	71.0	71.0	71.0	80.6	67.7	71.0	48.4	71.0	71.0	71.0	48.4
61.00	71.0	71.0	71.0	87.1	71.0	71.0	45.2	71.0	71.0	71.0	45.2
60.50	74.2	74.2	61.3	87.1	74.2	74.2	45.2	74.2	74.2	74.2	45.2
60.00	0.0	0.0	48.4	0.0	0.0	0.0	0.0	0.0	0.0	0.0	0.0
59.60	0.0	0.0	48.4	0.0	0.0	0.0	0.0	0.0	0.0	0.0	0.0
59.35	0.0	0.0	48.4	0.0	0.0	0.0	0.0	0.0	0.0	0.0	0.0
59.10	0.0	0.0	48.4	0.0	0.0	0.0	0.0	0.0	0.0	0.0	0.0
58.90	0.0	0.0	48.4	0.0	0.0	0.0	0.0	0.0	0.0	0.0	0.0
58.50	0.0	0.0	48.4	0.0	0.0	0.0	0.0	0.0	0.0	0.0	0.0
58.30	0.0	0.0	48.4	0.0	0.0	0.0	0.0	0.0	0.0	0.0	0.0
58.00	0.0	0.0	48.4	0.0	0.0	0.0	0.0	0.0	0.0	0.0	0.0
57.70	0.0	0.0	45.2	0.0	0.0	0.0	0.0	0.0	0.0	0.0	0.0
57.50	0.0	0.0	41.9	0.0	0.0	0.0	0.0	0.0	0.0	0.0	0.0
57.25	0.0	0.0	38.7	0.0	0.0	0.0	0.0	0.0	0.0	0.0	0.0
57.00	0.0	0.0	38.7	0.0	0.0	0.0	0.0	0.0	0.0	0.0	0.0
56.70	0.0	0.0	48.4	0.0	0.0	0.0	0.0	0.0	0.0	0.0	0.0
56.55	0.0	0.0	48.4	0.0	0.0	0.0	0.0	0.0	0.0	0.0	0.0
56.45	0.0	0.0	48.4	0.0	0.0	0.0	0.0	0.0	0.0	0.0	0.0
56.30	0.0	0.0	48.4	0.0	0.0	0.0	0.0	0.0	0.0	0.0	0.0
56.00	0.0	0.0	48.4	0.0	0.0	0.0	0.0	0.0	0.0	0.0	0.0
55.80	0.0	0.0	48.4	0.0	0.0	0.0	0.0	0.0	0.0	0.0	0.0
55.60	0.0	0.0	51.6	0.0	0.0	0.0	0.0	0.0	0.0	0.0	0.0
55.20	0.0	0.0	51.6	0.0	0.0	0.0	0.0	0.0	0.0	0.0	0.0
55.00	0.0	0.0	51.6	0.0	0.0	0.0	0.0	0.0	0.0	0.0	0.0
54.90	0.0	0.0	51.6	0.0	0.0	0.0	0.0	0.0	0.0	0.0	0.0
54.70	0.0	0.0	51.6	0.0	0.0	0.0	0.0	0.0	0.0	0.0	0.0
54.50	0.0	0.0	51.6	0.0	0.0	0.0	0.0	0.0	0.0	0.0	0.0
54.10	0.0	0.0	51.6	0.0	0.0	0.0	0.0	0.0	0.0	0.0	0.0
54.00	0.0	0.0	48.4	0.0	0.0	0.0	0.0	0.0	0.0	0.0	0.0
53.80	0.0	0.0	45.2	0.0	0.0	0.0	0.0	0.0	0.0	0.0	0.0
53.60	0.0	0.0	45.2	0.0	0.0	0.0	0.0	0.0	0.0	0.0	0.0
53.40	0.0	0.0	45.2	0.0	0.0	0.0	0.0	0.0	0.0	0.0	0.0
53.05	0.0	0.0	45.2	0.0	0.0	0.0	0.0	0.0	0.0	0.0	0.0
52.90	0.0	0.0	45.2	0.0	0.0	0.0	0.0	0.0	0.0	0.0	0.0
52.30	0.0	0.0	48.4	0.0	0.0	0.0	0.0	0.0	0.0	0.0	0.0
52.15	0.0	0.0	48.4	0.0	0.0	0.0	0.0	0.0	0.0	0.0	0.0
52.00	0.0	0.0	48.4	0.0	0.0	0.0	0.0	0.0	0.0	0.0	0.0
51.70	0.0	0.0	48.4	0.0	0.0	0.0	0.0	0.0	0.0	0.0	0.0
51.40	0.0	0.0	48.4	0.0	0.0	0.0	0.0	0.0	0.0	0.0	0.0
51.05	0.0	0.0	45.2	0.0	0.0	0.0	0.0	0.0	0.0	0.0	0.0
50.85	0.0	0.0	45.2	0.0	0.0	0.0	0.0	0.0	0.0	0.0	0.0
50.65	0.0	0.0	41.9	0.0	0.0	0.0	0.0	0.0	0.0	0.0	0.0

Table H3. Percentage of time the 7-day moving average of daily maximum simulated July 1994 water temperatures exceeds 17.8 degrees Celsius along the main stem of the Tualatin River for each scenario—Continued

River mile	Scenario:										
	1	2	3	4a	4b	5	6	7	8	9	10
50.50	0.0	0.0	41.9	0.0	0.0	0.0	0.0	0.0	0.0	0.0	0.0
50.30	0.0	0.0	41.9	0.0	0.0	0.0	0.0	0.0	0.0	0.0	0.0
50.20	0.0	0.0	41.9	0.0	0.0	0.0	0.0	0.0	0.0	0.0	0.0
50.10	0.0	0.0	41.9	0.0	0.0	0.0	0.0	0.0	0.0	0.0	0.0
49.80	0.0	0.0	41.9	0.0	0.0	0.0	0.0	0.0	0.0	0.0	0.0
49.60	0.0	0.0	45.2	0.0	0.0	0.0	0.0	0.0	0.0	0.0	0.0
49.40	0.0	0.0	45.2	0.0	0.0	0.0	0.0	0.0	0.0	0.0	0.0
49.15	0.0	0.0	45.2	0.0	0.0	0.0	0.0	0.0	0.0	0.0	0.0
49.05	0.0	0.0	45.2	0.0	0.0	0.0	0.0	0.0	0.0	0.0	0.0
48.50	0.0	0.0	41.9	0.0	0.0	0.0	0.0	0.0	0.0	0.0	0.0
48.35	0.0	0.0	41.9	0.0	0.0	0.0	0.0	0.0	0.0	0.0	0.0
48.00	0.0	0.0	41.9	0.0	0.0	0.0	0.0	0.0	0.0	0.0	0.0
47.70	0.0	0.0	41.9	0.0	0.0	0.0	0.0	0.0	0.0	0.0	0.0
47.00	0.0	0.0	45.2	0.0	0.0	0.0	0.0	0.0	0.0	0.0	0.0
46.85	0.0	0.0	45.2	0.0	0.0	0.0	0.0	0.0	0.0	0.0	0.0
46.55	0.0	0.0	45.2	0.0	0.0	0.0	0.0	0.0	0.0	0.0	0.0
46.40	0.0	0.0	45.2	0.0	0.0	0.0	0.0	0.0	0.0	0.0	0.0
46.00	0.0	0.0	38.7	0.0	0.0	0.0	0.0	0.0	0.0	0.0	0.0
45.50	0.0	0.0	38.7	0.0	0.0	0.0	0.0	0.0	0.0	0.0	0.0
45.35	0.0	0.0	41.9	0.0	0.0	0.0	0.0	0.0	0.0	0.0	0.0
45.20	0.0	0.0	45.2	0.0	0.0	0.0	0.0	0.0	0.0	0.0	0.0
44.80	0.0	38.7	48.4	0.0	0.0	0.0	0.0	0.0	38.7	0.0	0.0
44.10	0.0	48.4	45.2	0.0	0.0	0.0	0.0	0.0	48.4	0.0	0.0
43.90	0.0	48.4	45.2	0.0	0.0	0.0	0.0	0.0	48.4	0.0	0.0
43.70	0.0	51.6	45.2	0.0	0.0	0.0	0.0	0.0	51.6	0.0	0.0
43.50	0.0	51.6	45.2	0.0	0.0	0.0	0.0	0.0	51.6	0.0	0.0
43.05	0.0	54.8	45.2	3.2	0.0	0.0	0.0	0.0	54.8	0.0	0.0
42.70	0.0	58.1	45.2	12.9	0.0	0.0	0.0	0.0	58.1	0.0	0.0
42.50	0.0	61.3	45.2	12.9	0.0	0.0	0.0	0.0	61.3	0.0	0.0
41.90	0.0	67.7	45.2	32.3	0.0	0.0	0.0	0.0	67.7	0.0	0.0
41.50	0.0	74.2	45.2	35.5	0.0	0.0	0.0	0.0	74.2	0.0	0.0
41.00	0.0	74.2	45.2	48.4	0.0	0.0	0.0	0.0	74.2	0.0	0.0
40.60	0.0	74.2	45.2	61.3	0.0	0.0	0.0	0.0	74.2	0.0	0.0
40.40	0.0	74.2	45.2	64.5	0.0	0.0	0.0	0.0	74.2	0.0	0.0
40.00	0.0	74.2	45.2	67.7	0.0	0.0	0.0	0.0	74.2	0.0	0.0
39.75	3.2	74.2	45.2	71.0	0.0	3.2	0.0	3.2	74.2	3.2	0.0
39.50	3.2	74.2	45.2	74.2	0.0	3.2	0.0	3.2	74.2	3.2	0.0
39.00	9.7	74.2	45.2	74.2	0.0	9.7	0.0	9.7	74.2	9.7	0.0
38.80	9.7	74.2	45.2	74.2	0.0	9.7	0.0	9.7	74.2	9.7	0.0
38.40	6.5	74.2	45.2	74.2	0.0	6.5	0.0	9.7	74.2	9.7	0.0
37.98	67.7	83.9	51.6	83.9	0.0	61.3	0.0	25.8	77.4	25.8	0.0
37.70	74.2	83.9	54.8	90.3	3.2	74.2	0.0	32.3	77.4	32.3	0.0
37.42	74.2	90.3	58.1	90.3	9.7	74.2	0.0	35.5	77.4	35.5	0.0
37.14	77.4	90.3	64.5	93.5	16.1	77.4	3.2	38.7	77.4	38.7	0.0
36.86	80.6	93.5	67.7	100.0	22.6	80.6	12.9	48.4	83.9	48.4	0.0
36.58	80.6	93.5	71.0	100.0	22.6	80.6	16.1	48.4	83.9	48.4	0.0
36.30	80.6	93.5	74.2	100.0	22.6	80.6	22.6	58.1	83.9	58.1	0.0
36.02	83.9	100.0	74.2	100.0	29.0	83.9	22.6	74.2	83.9	74.2	0.0
35.74	83.9	100.0	74.2	100.0	29.0	83.9	22.6	74.2	83.9	74.2	6.5
35.46	83.9	100.0	74.2	100.0	38.7	83.9	29.0	74.2	80.6	74.2	6.5

Table H3. Percentage of time the 7-day moving average of daily maximum simulated July 1994 water temperatures exceeds 17.8 degrees Celsius along the main stem of the Tualatin River for each scenario—Continued

River mile	Scenario:										
	1	2	3	4a	4b	5	6	7	8	9	10
35.18	83.9	100.0	74.2	100.0	41.9	83.9	29.0	74.2	83.9	74.2	16.1
34.90	83.9	100.0	77.4	100.0	61.3	83.9	32.3	77.4	83.9	77.4	16.1
34.62	83.9	100.0	77.4	100.0	61.3	83.9	35.5	77.4	83.9	77.4	22.6
34.34	83.9	100.0	77.4	100.0	58.1	83.9	35.5	77.4	83.9	77.4	22.6
34.06	83.9	100.0	77.4	100.0	58.1	83.9	35.5	77.4	83.9	77.4	22.6
33.78	80.6	96.8	74.2	100.0	45.2	80.6	32.3	74.2	80.6	74.2	22.6
33.50	80.6	100.0	74.2	100.0	48.4	83.9	32.3	74.2	80.6	74.2	22.6
33.22	80.6	93.5	74.2	100.0	48.4	83.9	32.3	74.2	83.9	77.4	25.8
32.94	80.6	93.5	74.2	100.0	48.4	83.9	32.3	74.2	83.9	77.4	25.8
32.66	80.6	93.5	74.2	100.0	51.6	83.9	32.3	77.4	87.1	77.4	25.8
32.38	83.9	93.5	74.2	100.0	54.8	83.9	35.5	77.4	87.1	80.6	29.0
32.10	83.9	96.8	77.4	100.0	58.1	83.9	54.8	80.6	90.3	80.6	32.3
31.82	83.9	100.0	77.4	100.0	67.7	87.1	58.1	83.9	93.5	83.9	35.5
31.54	90.3	100.0	77.4	100.0	74.2	90.3	74.2	83.9	93.5	83.9	41.9
31.26	90.3	100.0	80.6	100.0	74.2	93.5	74.2	87.1	93.5	87.1	74.2
30.98	90.3	100.0	77.4	100.0	74.2	90.3	74.2	83.9	90.3	83.9	45.2
30.70	90.3	100.0	77.4	100.0	74.2	93.5	74.2	87.1	90.3	87.1	61.3
30.42	93.5	100.0	80.6	100.0	74.2	96.8	74.2	87.1	96.8	87.1	74.2
30.14	93.5	100.0	80.6	100.0	77.4	100.0	77.4	90.3	100.0	90.3	74.2
29.86	93.5	100.0	80.6	100.0	77.4	100.0	77.4	90.3	100.0	90.3	74.2
29.58	96.8	100.0	80.6	100.0	77.4	100.0	77.4	90.3	100.0	90.3	74.2
29.30	96.8	100.0	77.4	100.0	77.4	100.0	77.4	87.1	100.0	87.1	71.0
29.02	100.0	100.0	80.6	100.0	77.4	100.0	77.4	90.3	100.0	90.3	74.2
28.74	100.0	100.0	80.6	100.0	77.4	100.0	77.4	90.3	100.0	90.3	74.2
28.46	100.0	100.0	83.9	100.0	80.6	100.0	77.4	87.1	100.0	87.1	74.2
28.24	87.1	100.0	77.4	100.0	74.2	87.1	71.0	83.9	93.5	83.9	58.1
28.10	93.5	100.0	80.6	100.0	74.2	96.8	74.2	87.1	100.0	87.1	74.2
27.90	93.5	100.0	80.6	100.0	74.2	93.5	74.2	87.1	100.0	87.1	74.2
27.62	100.0	100.0	83.9	100.0	77.4	96.8	77.4	93.5	100.0	87.1	74.2
27.34	100.0	100.0	87.1	100.0	80.6	100.0	77.4	93.5	100.0	93.5	74.2
27.09	93.5	100.0	83.9	100.0	80.6	93.5	74.2	90.3	100.0	83.9	74.2
26.95	96.8	100.0	83.9	100.0	80.6	93.5	74.2	90.3	100.0	90.3	74.2
26.85	100.0	100.0	83.9	100.0	80.6	100.0	77.4	90.3	100.0	90.3	74.2
26.71	100.0	100.0	83.9	100.0	80.6	100.0	80.6	93.5	100.0	90.3	74.2
26.50	100.0	100.0	90.3	100.0	80.6	100.0	80.6	100.0	100.0	93.5	74.2
26.29	100.0	100.0	93.5	100.0	87.1	100.0	83.9	100.0	100.0	100.0	80.6
26.15	100.0	100.0	87.1	100.0	80.6	100.0	80.6	96.8	100.0	90.3	74.2
25.94	100.0	100.0	93.5	100.0	87.1	100.0	83.9	100.0	100.0	100.0	80.6
25.73	100.0	100.0	96.8	100.0	87.1	100.0	87.1	100.0	100.0	100.0	80.6
25.59	100.0	100.0	96.8	100.0	87.1	100.0	87.1	100.0	100.0	100.0	80.6
25.38	100.0	100.0	100.0	100.0	87.1	100.0	87.1	100.0	100.0	100.0	83.9
25.10	100.0	100.0	96.8	100.0	87.1	100.0	87.1	100.0	100.0	100.0	83.9
24.91	100.0	100.0	100.0	100.0	90.3	100.0	87.1	100.0	100.0	100.0	83.9
24.80	100.0	100.0	93.5	100.0	83.9	100.0	83.9	100.0	100.0	100.0	77.4
24.72	100.0	100.0	100.0	100.0	87.1	100.0	87.1	100.0	100.0	100.0	83.9
24.54	100.0	100.0	100.0	100.0	90.3	100.0	87.1	100.0	100.0	100.0	83.9
24.26	100.0	100.0	100.0	100.0	93.5	100.0	93.5	100.0	100.0	100.0	87.1
24.05	100.0	100.0	100.0	100.0	90.3	100.0	90.3	100.0	100.0	100.0	87.1
23.91	100.0	100.0	100.0	100.0	90.3	100.0	90.3	100.0	100.0	100.0	87.1
23.70	100.0	100.0	100.0	100.0	96.8	100.0	96.8	100.0	100.0	100.0	90.3

Table H3. Percentage of time the 7-day moving average of daily maximum simulated July 1994 water temperatures exceeds 17.8 degrees Celsius along the main stem of the Tualatin River for each scenario—Continued

River mile	Scenario:										
	1	2	3	4a	4b	5	6	7	8	9	10
23.42	100.0	100.0	93.5	100.0	87.1	100.0	83.9	100.0	100.0	100.0	80.6
23.23	100.0	100.0	100.0	100.0	100.0	100.0	100.0	100.0	100.0	100.0	96.8
23.15	100.0	100.0	100.0	100.0	90.3	100.0	90.3	100.0	100.0	100.0	83.9
23.09	100.0	100.0	100.0	100.0	90.3	100.0	90.3	100.0	100.0	100.0	87.1
23.03	100.0	100.0	100.0	100.0	100.0	100.0	100.0	100.0	100.0	100.0	100.0
22.86	100.0	100.0	100.0	100.0	100.0	100.0	100.0	100.0	100.0	100.0	100.0
22.58	100.0	100.0	100.0	100.0	100.0	100.0	100.0	100.0	100.0	100.0	100.0
22.30	100.0	100.0	100.0	100.0	100.0	100.0	100.0	100.0	100.0	100.0	100.0
22.02	100.0	100.0	100.0	100.0	100.0	100.0	100.0	100.0	100.0	100.0	100.0
21.82	100.0	100.0	100.0	100.0	93.5	100.0	93.5	100.0	100.0	100.0	83.9
21.68	100.0	100.0	100.0	100.0	100.0	100.0	100.0	100.0	100.0	100.0	96.8
21.46	100.0	100.0	100.0	100.0	100.0	100.0	100.0	100.0	100.0	100.0	100.0
21.25	100.0	100.0	100.0	100.0	100.0	100.0	100.0	100.0	100.0	100.0	100.0
21.11	100.0	100.0	100.0	100.0	100.0	100.0	100.0	100.0	100.0	100.0	100.0
20.90	100.0	100.0	100.0	100.0	100.0	100.0	100.0	100.0	100.0	100.0	100.0
20.69	100.0	100.0	100.0	100.0	100.0	100.0	100.0	100.0	100.0	100.0	100.0
20.55	100.0	100.0	100.0	100.0	100.0	100.0	100.0	100.0	100.0	100.0	100.0
20.34	100.0	100.0	100.0	100.0	100.0	100.0	100.0	100.0	100.0	100.0	100.0
20.06	100.0	100.0	100.0	100.0	100.0	100.0	100.0	100.0	100.0	100.0	100.0
19.78	100.0	100.0	100.0	100.0	100.0	100.0	100.0	100.0	100.0	100.0	100.0
19.50	100.0	100.0	100.0	100.0	100.0	100.0	100.0	100.0	100.0	100.0	100.0
19.22	100.0	100.0	100.0	100.0	100.0	100.0	100.0	100.0	100.0	100.0	100.0
18.94	100.0	100.0	100.0	100.0	100.0	100.0	100.0	100.0	100.0	100.0	100.0
18.66	100.0	100.0	100.0	100.0	100.0	100.0	100.0	100.0	100.0	100.0	100.0
18.38	100.0	100.0	100.0	100.0	100.0	100.0	100.0	100.0	100.0	100.0	100.0
18.17	100.0	100.0	100.0	100.0	100.0	100.0	100.0	100.0	100.0	100.0	100.0
18.03	100.0	100.0	100.0	100.0	100.0	100.0	100.0	100.0	100.0	100.0	100.0
17.82	100.0	100.0	100.0	100.0	100.0	100.0	100.0	100.0	100.0	100.0	100.0
17.54	100.0	100.0	100.0	100.0	100.0	100.0	100.0	100.0	100.0	100.0	100.0
17.26	100.0	100.0	100.0	100.0	100.0	100.0	100.0	100.0	100.0	100.0	100.0
17.00	100.0	100.0	100.0	100.0	100.0	100.0	100.0	100.0	100.0	100.0	100.0
16.86	100.0	100.0	100.0	100.0	100.0	100.0	100.0	100.0	100.0	100.0	100.0
16.70	100.0	100.0	100.0	100.0	100.0	100.0	100.0	100.0	100.0	100.0	100.0
16.44	100.0	100.0	100.0	100.0	100.0	100.0	100.0	100.0	100.0	100.0	100.0
16.30	100.0	100.0	100.0	100.0	100.0	100.0	100.0	100.0	100.0	100.0	100.0
16.14	100.0	100.0	100.0	100.0	100.0	100.0	100.0	100.0	100.0	100.0	100.0
15.86	100.0	100.0	100.0	100.0	100.0	100.0	100.0	100.0	100.0	100.0	100.0
15.58	100.0	100.0	100.0	100.0	100.0	100.0	100.0	100.0	100.0	100.0	100.0
15.30	100.0	100.0	100.0	100.0	100.0	100.0	100.0	100.0	100.0	100.0	100.0
15.02	100.0	100.0	100.0	100.0	100.0	100.0	100.0	100.0	100.0	100.0	100.0
14.74	100.0	100.0	100.0	100.0	100.0	100.0	100.0	100.0	100.0	100.0	100.0
14.46	100.0	100.0	100.0	100.0	100.0	100.0	100.0	100.0	100.0	100.0	100.0
14.18	100.0	100.0	100.0	100.0	100.0	100.0	100.0	100.0	100.0	100.0	100.0
13.90	100.0	100.0	100.0	100.0	100.0	100.0	100.0	100.0	100.0	100.0	100.0
13.62	100.0	100.0	100.0	100.0	100.0	100.0	100.0	100.0	100.0	100.0	100.0
13.34	100.0	100.0	100.0	100.0	100.0	100.0	100.0	100.0	100.0	100.0	100.0
13.18	100.0	100.0	100.0	100.0	100.0	100.0	100.0	100.0	100.0	100.0	100.0
13.04	100.0	100.0	100.0	100.0	100.0	100.0	100.0	100.0	100.0	100.0	100.0
12.78	100.0	100.0	100.0	100.0	100.0	100.0	100.0	100.0	100.0	100.0	100.0
12.57	100.0	100.0	100.0	100.0	100.0	100.0	100.0	100.0	100.0	100.0	100.0

Table H3. Percentage of time the 7-day moving average of daily maximum simulated July 1994 water temperatures exceeds 17.8 degrees Celsius along the main stem of the Tualatin River for each scenario—Continued

River mile	Scenario:										
	1	2	3	4a	4b	5	6	7	8	9	10
12.43	100.0	100.0	100.0	100.0	100.0	100.0	100.0	100.0	100.0	100.0	100.0
12.22	100.0	100.0	100.0	100.0	100.0	100.0	100.0	100.0	100.0	100.0	100.0
12.04	100.0	100.0	100.0	100.0	100.0	100.0	100.0	100.0	100.0	100.0	100.0
11.90	100.0	100.0	100.0	100.0	100.0	100.0	100.0	100.0	100.0	100.0	100.0
11.66	100.0	100.0	100.0	100.0	100.0	100.0	100.0	100.0	100.0	100.0	100.0
11.38	100.0	100.0	100.0	100.0	100.0	100.0	100.0	100.0	100.0	100.0	100.0
11.10	100.0	100.0	100.0	100.0	100.0	100.0	100.0	100.0	100.0	100.0	100.0
10.89	100.0	100.0	100.0	100.0	100.0	100.0	100.0	100.0	100.0	100.0	100.0
10.75	100.0	100.0	100.0	100.0	100.0	100.0	100.0	100.0	100.0	100.0	100.0
10.54	100.0	100.0	100.0	100.0	100.0	100.0	100.0	100.0	100.0	100.0	100.0
10.26	100.0	100.0	100.0	100.0	100.0	100.0	100.0	100.0	100.0	100.0	100.0
9.98	100.0	100.0	100.0	100.0	100.0	100.0	100.0	100.0	100.0	100.0	100.0
9.70	100.0	100.0	100.0	100.0	100.0	100.0	100.0	100.0	100.0	100.0	100.0
9.42	100.0	100.0	100.0	100.0	100.0	100.0	100.0	100.0	100.0	100.0	100.0
9.14	100.0	100.0	100.0	100.0	100.0	100.0	100.0	100.0	100.0	100.0	100.0
8.86	100.0	100.0	100.0	100.0	100.0	100.0	100.0	100.0	100.0	100.0	100.0
8.58	100.0	100.0	100.0	100.0	100.0	100.0	100.0	100.0	100.0	100.0	100.0
8.30	100.0	100.0	100.0	100.0	100.0	100.0	100.0	100.0	100.0	100.0	100.0
8.02	100.0	100.0	100.0	100.0	100.0	100.0	100.0	100.0	100.0	100.0	100.0
7.74	100.0	100.0	100.0	100.0	100.0	100.0	100.0	100.0	100.0	100.0	100.0
7.46	100.0	100.0	100.0	100.0	100.0	100.0	100.0	100.0	100.0	100.0	100.0
7.25	100.0	100.0	100.0	100.0	100.0	100.0	100.0	100.0	100.0	100.0	100.0
7.11	100.0	100.0	100.0	100.0	100.0	100.0	100.0	100.0	100.0	100.0	100.0
6.90	100.0	100.0	100.0	100.0	100.0	100.0	100.0	100.0	100.0	100.0	100.0
6.62	100.0	100.0	100.0	100.0	100.0	100.0	100.0	100.0	100.0	100.0	100.0
6.34	100.0	100.0	100.0	100.0	100.0	100.0	100.0	100.0	100.0	100.0	100.0
6.13	100.0	100.0	100.0	100.0	100.0	100.0	100.0	100.0	100.0	100.0	100.0
5.99	100.0	100.0	100.0	100.0	100.0	100.0	100.0	100.0	100.0	100.0	100.0
5.81	100.0	100.0	100.0	100.0	100.0	100.0	100.0	100.0	100.0	100.0	100.0
5.67	100.0	100.0	100.0	100.0	100.0	100.0	100.0	100.0	100.0	100.0	100.0
5.57	100.0	100.0	100.0	100.0	100.0	100.0	100.0	100.0	100.0	100.0	100.0
5.43	100.0	100.0	100.0	100.0	100.0	100.0	100.0	100.0	100.0	100.0	100.0
5.34	100.0	100.0	100.0	100.0	100.0	100.0	100.0	100.0	100.0	100.0	100.0
5.20	100.0	100.0	100.0	100.0	100.0	100.0	100.0	100.0	100.0	100.0	100.0
5.01	100.0	100.0	100.0	100.0	100.0	100.0	100.0	100.0	100.0	100.0	100.0
4.87	100.0	100.0	100.0	100.0	100.0	100.0	100.0	100.0	100.0	100.0	100.0
4.66	100.0	100.0	100.0	100.0	100.0	100.0	100.0	100.0	100.0	100.0	100.0
4.38	100.0	100.0	100.0	100.0	100.0	100.0	100.0	100.0	100.0	100.0	100.0
4.17	100.0	100.0	100.0	100.0	100.0	100.0	100.0	100.0	100.0	100.0	100.0
4.03	100.0	100.0	100.0	100.0	100.0	100.0	100.0	100.0	100.0	100.0	100.0
3.82	100.0	100.0	100.0	100.0	100.0	100.0	100.0	100.0	100.0	100.0	100.0

Table H4. Percentage of time the 7-day moving average of daily maximum simulated August 1994 water temperatures exceeds 17.8 degrees Celsius along the main stem of the Tualatin River for each scenario

River mile	Scenario:										
	1	2	3	4a	4b	5	6	7	8	9	10
63.90	100.0	100.0	100.0	100.0	100.0	100.0	45.2	100.0	100.0	100.0	45.2
63.75	100.0	100.0	100.0	100.0	100.0	100.0	38.7	100.0	100.0	100.0	38.7
63.50	100.0	100.0	83.9	100.0	100.0	100.0	35.5	100.0	100.0	100.0	35.5
63.00	90.3	90.3	67.7	93.5	90.3	90.3	16.1	90.3	90.3	90.3	16.1
62.50	83.9	83.9	61.3	100.0	67.7	83.9	0.0	83.9	83.9	83.9	0.0
62.25	93.5	93.5	58.1	100.0	67.7	93.5	0.0	93.5	93.5	93.5	0.0
62.00	100.0	100.0	41.9	100.0	67.7	100.0	0.0	100.0	100.0	100.0	0.0
61.90	96.8	96.8	38.7	100.0	71.0	96.8	0.0	96.8	96.8	96.8	0.0
61.50	93.5	93.5	32.3	100.0	71.0	93.5	6.5	93.5	93.5	93.5	6.5
61.00	87.1	87.1	32.3	100.0	64.5	87.1	9.7	87.1	87.1	87.1	9.7
60.50	67.7	67.7	38.7	100.0	58.1	67.7	0.0	67.7	67.7	67.7	0.0
60.00	0.0	0.0	3.2	0.0	0.0	0.0	0.0	0.0	0.0	0.0	0.0
59.60	0.0	0.0	0.0	0.0	0.0	0.0	0.0	0.0	0.0	0.0	0.0
59.35	0.0	0.0	0.0	0.0	0.0	0.0	0.0	0.0	0.0	0.0	0.0
59.10	0.0	0.0	3.2	0.0	0.0	0.0	0.0	0.0	0.0	0.0	0.0
58.90	0.0	0.0	3.2	0.0	0.0	0.0	0.0	0.0	0.0	0.0	0.0
58.50	0.0	0.0	3.2	0.0	0.0	0.0	0.0	0.0	0.0	0.0	0.0
58.30	0.0	0.0	3.2	0.0	0.0	0.0	0.0	0.0	0.0	0.0	0.0
58.00	0.0	0.0	3.2	0.0	0.0	0.0	0.0	0.0	0.0	0.0	0.0
57.70	0.0	0.0	0.0	0.0	0.0	0.0	0.0	0.0	0.0	0.0	0.0
57.50	0.0	0.0	0.0	0.0	0.0	0.0	0.0	0.0	0.0	0.0	0.0
57.25	0.0	0.0	0.0	0.0	0.0	0.0	0.0	0.0	0.0	0.0	0.0
57.00	0.0	0.0	0.0	0.0	0.0	0.0	0.0	0.0	0.0	0.0	0.0
56.70	0.0	0.0	0.0	0.0	0.0	0.0	0.0	0.0	0.0	0.0	0.0
56.55	0.0	0.0	0.0	0.0	0.0	0.0	0.0	0.0	0.0	0.0	0.0
56.45	0.0	0.0	3.2	0.0	0.0	0.0	0.0	0.0	0.0	0.0	0.0
56.30	0.0	0.0	3.2	0.0	0.0	0.0	0.0	0.0	0.0	0.0	0.0
56.00	0.0	0.0	3.2	0.0	0.0	0.0	0.0	0.0	0.0	0.0	0.0
55.80	0.0	0.0	6.5	0.0	0.0	0.0	0.0	0.0	0.0	0.0	0.0
55.60	0.0	0.0	6.5	0.0	0.0	0.0	0.0	0.0	0.0	0.0	0.0
55.20	0.0	0.0	3.2	0.0	0.0	0.0	0.0	0.0	0.0	0.0	0.0
55.00	0.0	0.0	3.2	0.0	0.0	0.0	0.0	0.0	0.0	0.0	0.0
54.90	0.0	0.0	3.2	0.0	0.0	0.0	0.0	0.0	0.0	0.0	0.0
54.70	0.0	0.0	3.2	0.0	0.0	0.0	0.0	0.0	0.0	0.0	0.0
54.50	0.0	0.0	0.0	0.0	0.0	0.0	0.0	0.0	0.0	0.0	0.0
54.10	0.0	0.0	0.0	0.0	0.0	0.0	0.0	0.0	0.0	0.0	0.0
54.00	0.0	0.0	0.0	0.0	0.0	0.0	0.0	0.0	0.0	0.0	0.0
53.80	0.0	0.0	0.0	0.0	0.0	0.0	0.0	0.0	0.0	0.0	0.0
53.60	0.0	0.0	0.0	0.0	0.0	0.0	0.0	0.0	0.0	0.0	0.0
53.40	0.0	0.0	0.0	0.0	0.0	0.0	0.0	0.0	0.0	0.0	0.0
53.05	0.0	0.0	0.0	0.0	0.0	0.0	0.0	0.0	0.0	0.0	0.0
52.90	0.0	0.0	0.0	0.0	0.0	0.0	0.0	0.0	0.0	0.0	0.0
52.30	0.0	0.0	0.0	0.0	0.0	0.0	0.0	0.0	0.0	0.0	0.0
52.15	0.0	0.0	0.0	0.0	0.0	0.0	0.0	0.0	0.0	0.0	0.0
52.00	0.0	0.0	0.0	0.0	0.0	0.0	0.0	0.0	0.0	0.0	0.0
51.70	0.0	0.0	0.0	0.0	0.0	0.0	0.0	0.0	0.0	0.0	0.0
51.40	0.0	0.0	0.0	0.0	0.0	0.0	0.0	0.0	0.0	0.0	0.0
51.05	0.0	0.0	0.0	0.0	0.0	0.0	0.0	0.0	0.0	0.0	0.0
50.85	0.0	0.0	0.0	0.0	0.0	0.0	0.0	0.0	0.0	0.0	0.0
50.65	0.0	0.0	0.0	0.0	0.0	0.0	0.0	0.0	0.0	0.0	0.0

Table H4. Percentage of time the 7-day moving average of daily maximum simulated August 1994 water temperatures exceeds 17.8 degrees Celsius along the main stem of the Tualatin River for each scenario—Continued

River mile	Scenario:										
	1	2	3	4a	4b	5	6	7	8	9	10
50.50	0.0	0.0	0.0	0.0	0.0	0.0	0.0	0.0	0.0	0.0	0.0
50.30	0.0	0.0	0.0	0.0	0.0	0.0	0.0	0.0	0.0	0.0	0.0
50.20	0.0	0.0	0.0	0.0	0.0	0.0	0.0	0.0	0.0	0.0	0.0
50.10	0.0	0.0	0.0	0.0	0.0	0.0	0.0	0.0	0.0	0.0	0.0
49.80	0.0	0.0	0.0	0.0	0.0	0.0	0.0	0.0	0.0	0.0	0.0
49.60	0.0	0.0	0.0	0.0	0.0	0.0	0.0	0.0	0.0	0.0	0.0
49.40	0.0	0.0	0.0	0.0	0.0	0.0	0.0	0.0	0.0	0.0	0.0
49.15	0.0	0.0	0.0	0.0	0.0	0.0	0.0	0.0	0.0	0.0	0.0
49.05	0.0	0.0	0.0	0.0	0.0	0.0	0.0	0.0	0.0	0.0	0.0
48.50	0.0	0.0	0.0	0.0	0.0	0.0	0.0	0.0	0.0	0.0	0.0
48.35	0.0	0.0	0.0	0.0	0.0	0.0	0.0	0.0	0.0	0.0	0.0
48.00	0.0	0.0	0.0	0.0	0.0	0.0	0.0	0.0	0.0	0.0	0.0
47.70	0.0	0.0	0.0	0.0	0.0	0.0	0.0	0.0	0.0	0.0	0.0
47.00	0.0	0.0	0.0	0.0	0.0	0.0	0.0	0.0	0.0	0.0	0.0
46.85	0.0	0.0	0.0	0.0	0.0	0.0	0.0	0.0	0.0	0.0	0.0
46.55	0.0	0.0	0.0	0.0	0.0	0.0	0.0	0.0	0.0	0.0	0.0
46.40	0.0	0.0	0.0	0.0	0.0	0.0	0.0	0.0	0.0	0.0	0.0
46.00	0.0	0.0	0.0	0.0	0.0	0.0	0.0	0.0	0.0	0.0	0.0
45.50	0.0	0.0	0.0	0.0	0.0	0.0	0.0	0.0	0.0	0.0	0.0
45.35	0.0	0.0	0.0	0.0	0.0	0.0	0.0	0.0	0.0	0.0	0.0
45.20	0.0	0.0	0.0	0.0	0.0	0.0	0.0	0.0	0.0	0.0	0.0
44.80	0.0	9.7	3.2	0.0	0.0	0.0	0.0	0.0	9.7	0.0	0.0
44.10	0.0	12.9	3.2	0.0	0.0	0.0	0.0	0.0	12.9	0.0	0.0
43.90	0.0	12.9	3.2	0.0	0.0	0.0	0.0	0.0	12.9	0.0	0.0
43.70	0.0	16.1	3.2	0.0	0.0	0.0	0.0	0.0	16.1	0.0	0.0
43.50	0.0	16.1	3.2	0.0	0.0	0.0	0.0	0.0	16.1	0.0	0.0
43.05	0.0	16.1	3.2	0.0	0.0	0.0	0.0	0.0	16.1	0.0	0.0
42.70	0.0	16.1	3.2	0.0	0.0	0.0	0.0	0.0	16.1	0.0	0.0
42.50	0.0	16.1	3.2	0.0	0.0	0.0	0.0	0.0	16.1	0.0	0.0
41.90	0.0	19.4	3.2	0.0	0.0	0.0	0.0	0.0	19.4	0.0	0.0
41.50	0.0	22.6	0.0	0.0	0.0	0.0	0.0	0.0	22.6	0.0	0.0
41.00	0.0	22.6	3.2	0.0	0.0	0.0	0.0	0.0	22.6	0.0	0.0
40.60	0.0	29.0	3.2	0.0	0.0	0.0	0.0	0.0	29.0	0.0	0.0
40.40	0.0	32.3	3.2	3.2	0.0	0.0	0.0	0.0	32.3	0.0	0.0
40.00	0.0	32.3	3.2	6.5	0.0	0.0	0.0	0.0	32.3	0.0	0.0
39.75	0.0	32.3	3.2	9.7	0.0	0.0	0.0	0.0	32.3	0.0	0.0
39.50	0.0	32.3	3.2	12.9	0.0	0.0	0.0	0.0	32.3	0.0	0.0
39.00	0.0	41.9	3.2	22.6	0.0	0.0	0.0	0.0	41.9	0.0	0.0
38.80	0.0	41.9	3.2	22.6	0.0	0.0	0.0	0.0	41.9	0.0	0.0
38.40	0.0	22.6	0.0	19.4	0.0	0.0	0.0	0.0	38.7	0.0	0.0
37.98	25.8	100.0	9.7	90.3	0.0	22.6	0.0	0.0	54.8	0.0	0.0
37.70	58.1	100.0	16.1	100.0	0.0	58.1	0.0	0.0	61.3	0.0	0.0
37.42	61.3	100.0	35.5	100.0	0.0	61.3	0.0	0.0	74.2	0.0	0.0
37.14	61.3	100.0	38.7	100.0	0.0	61.3	0.0	0.0	74.2	0.0	0.0
36.86	67.7	100.0	48.4	100.0	0.0	67.7	0.0	0.0	74.2	0.0	0.0
36.58	67.7	100.0	61.3	100.0	0.0	67.7	0.0	0.0	80.6	0.0	0.0
36.30	67.7	100.0	64.5	100.0	0.0	67.7	0.0	3.2	80.6	3.2	0.0
36.02	74.2	100.0	64.5	100.0	6.5	74.2	0.0	6.5	80.6	6.5	0.0
35.74	77.4	100.0	64.5	100.0	12.9	77.4	6.5	12.9	80.6	12.9	0.0
35.46	80.6	100.0	61.3	100.0	12.9	80.6	6.5	12.9	74.2	12.9	0.0

Table H4. Percentage of time the 7-day moving average of daily maximum simulated August 1994 water temperatures exceeds 17.8 degrees Celsius along the main stem of the Tualatin River for each scenario—Continued

River mile	Scenario:										
	1	2	3	4a	4b	5	6	7	8	9	10
35.18	83.9	100.0	64.5	100.0	16.1	83.9	9.7	16.1	77.4	16.1	0.0
34.90	83.9	100.0	64.5	100.0	19.4	83.9	12.9	19.4	80.6	16.1	0.0
34.62	83.9	100.0	64.5	100.0	19.4	87.1	12.9	25.8	83.9	25.8	0.0
34.34	80.6	100.0	64.5	100.0	19.4	83.9	6.5	29.0	80.6	29.0	0.0
34.06	77.4	100.0	64.5	100.0	22.6	80.6	9.7	29.0	83.9	29.0	0.0
33.78	74.2	100.0	64.5	100.0	9.7	74.2	3.2	29.0	64.5	29.0	0.0
33.50	74.2	100.0	64.5	100.0	9.7	74.2	3.2	29.0	64.5	32.3	0.0
33.22	71.0	100.0	64.5	100.0	9.7	74.2	0.0	32.3	64.5	32.3	0.0
32.94	67.7	100.0	61.3	100.0	9.7	71.0	0.0	32.3	67.7	32.3	0.0
32.66	67.7	100.0	61.3	100.0	12.9	74.2	0.0	32.3	80.6	32.3	0.0
32.38	74.2	100.0	64.5	100.0	12.9	74.2	6.5	35.5	83.9	32.3	0.0
32.10	74.2	100.0	67.7	100.0	19.4	80.6	12.9	41.9	100.0	41.9	0.0
31.82	87.1	100.0	67.7	100.0	25.8	90.3	22.6	51.6	100.0	45.2	0.0
31.54	93.5	100.0	80.6	100.0	29.0	100.0	29.0	58.1	100.0	45.2	0.0
31.26	100.0	100.0	93.5	100.0	38.7	100.0	38.7	64.5	100.0	58.1	0.0
30.98	100.0	100.0	87.1	100.0	32.3	100.0	29.0	54.8	87.1	51.6	0.0
30.70	100.0	100.0	96.8	100.0	38.7	100.0	38.7	58.1	87.1	51.6	0.0
30.42	100.0	100.0	96.8	100.0	38.7	100.0	38.7	64.5	93.5	61.3	9.7
30.14	100.0	100.0	96.8	100.0	38.7	100.0	48.4	74.2	100.0	67.7	12.9
29.86	100.0	100.0	83.9	100.0	38.7	100.0	54.8	74.2	100.0	67.7	16.1
29.58	100.0	100.0	80.6	100.0	48.4	100.0	54.8	77.4	100.0	71.0	19.4
29.30	100.0	100.0	71.0	100.0	48.4	100.0	54.8	77.4	100.0	71.0	22.6
29.02	100.0	100.0	87.1	100.0	51.6	100.0	61.3	80.6	100.0	74.2	32.3
28.74	100.0	100.0	96.8	100.0	51.6	100.0	54.8	80.6	100.0	74.2	29.0
28.46	100.0	100.0	96.8	100.0	51.6	100.0	54.8	80.6	100.0	71.0	29.0
28.24	83.9	100.0	74.2	100.0	38.7	83.9	38.7	48.4	87.1	48.4	0.0
28.10	96.8	100.0	100.0	100.0	45.2	90.3	45.2	71.0	100.0	61.3	22.6
27.90	100.0	100.0	100.0	100.0	45.2	90.3	48.4	80.6	100.0	67.7	29.0
27.62	100.0	100.0	100.0	100.0	54.8	100.0	61.3	87.1	100.0	87.1	38.7
27.34	100.0	100.0	100.0	100.0	71.0	100.0	74.2	90.3	100.0	87.1	38.7
27.09	100.0	100.0	96.8	100.0	54.8	100.0	61.3	80.6	100.0	80.6	38.7
26.95	100.0	100.0	100.0	100.0	54.8	100.0	67.7	83.9	100.0	83.9	38.7
26.85	100.0	100.0	100.0	100.0	64.5	100.0	71.0	87.1	100.0	83.9	41.9
26.71	100.0	100.0	100.0	100.0	71.0	100.0	77.4	87.1	100.0	83.9	45.2
26.50	100.0	100.0	100.0	100.0	74.2	100.0	83.9	90.3	100.0	90.3	48.4
26.29	100.0	100.0	100.0	100.0	83.9	100.0	90.3	100.0	100.0	93.5	54.8
26.15	100.0	100.0	100.0	100.0	61.3	100.0	80.6	87.1	100.0	87.1	45.2
25.94	100.0	100.0	100.0	100.0	83.9	100.0	90.3	100.0	100.0	93.5	54.8
25.73	100.0	100.0	100.0	100.0	90.3	100.0	90.3	100.0	100.0	100.0	58.1
25.59	100.0	100.0	100.0	100.0	87.1	100.0	90.3	100.0	100.0	100.0	61.3
25.38	100.0	100.0	100.0	100.0	87.1	100.0	93.5	100.0	100.0	100.0	77.4
25.10	100.0	100.0	100.0	100.0	87.1	100.0	90.3	100.0	100.0	100.0	74.2
24.91	100.0	100.0	100.0	100.0	93.5	100.0	100.0	100.0	100.0	100.0	80.6
24.80	100.0	100.0	100.0	100.0	83.9	100.0	87.1	100.0	100.0	93.5	67.7
24.72	100.0	100.0	100.0	100.0	93.5	100.0	100.0	100.0	100.0	100.0	80.6
24.54	100.0	100.0	100.0	100.0	93.5	100.0	100.0	100.0	100.0	100.0	87.1
24.26	100.0	100.0	100.0	100.0	100.0	100.0	100.0	100.0	100.0	100.0	90.3
24.05	100.0	100.0	100.0	100.0	100.0	100.0	100.0	100.0	100.0	100.0	90.3
23.91	100.0	100.0	100.0	100.0	100.0	100.0	100.0	100.0	100.0	100.0	87.1
23.70	100.0	100.0	100.0	100.0	100.0	100.0	100.0	100.0	100.0	100.0	90.3

Table H4. Percentage of time the 7-day moving average of daily maximum simulated August 1994 water temperatures exceeds 17.8 degrees Celsius along the main stem of the Tualatin River for each scenario—Continued

River mile	Scenario:										
	1	2	3	4a	4b	5	6	7	8	9	10
23.42	100.0	100.0	100.0	100.0	83.9	100.0	90.3	100.0	100.0	93.5	64.5
23.23	100.0	100.0	100.0	100.0	100.0	100.0	100.0	100.0	100.0	100.0	96.8
23.15	100.0	100.0	100.0	100.0	96.8	100.0	100.0	100.0	100.0	100.0	87.1
23.09	100.0	100.0	100.0	100.0	96.8	100.0	100.0	100.0	100.0	100.0	87.1
23.03	100.0	100.0	100.0	100.0	100.0	100.0	100.0	100.0	100.0	100.0	100.0
22.86	100.0	100.0	100.0	100.0	100.0	100.0	100.0	100.0	100.0	100.0	100.0
22.58	100.0	100.0	100.0	100.0	100.0	100.0	100.0	100.0	100.0	100.0	100.0
22.30	100.0	100.0	100.0	100.0	100.0	100.0	100.0	100.0	100.0	100.0	100.0
22.02	100.0	100.0	100.0	100.0	100.0	100.0	100.0	100.0	100.0	100.0	100.0
21.82	100.0	100.0	100.0	100.0	96.8	100.0	100.0	100.0	100.0	100.0	83.9
21.68	100.0	100.0	100.0	100.0	100.0	100.0	100.0	100.0	100.0	100.0	100.0
21.46	100.0	100.0	100.0	100.0	100.0	100.0	100.0	100.0	100.0	100.0	100.0
21.25	100.0	100.0	100.0	100.0	100.0	100.0	100.0	100.0	100.0	100.0	100.0
21.11	100.0	100.0	100.0	100.0	100.0	100.0	100.0	100.0	100.0	100.0	100.0
20.90	100.0	100.0	100.0	100.0	100.0	100.0	100.0	100.0	100.0	100.0	100.0
20.69	100.0	100.0	100.0	100.0	100.0	100.0	100.0	100.0	100.0	100.0	100.0
20.55	100.0	100.0	100.0	100.0	100.0	100.0	100.0	100.0	100.0	100.0	100.0
20.34	100.0	100.0	100.0	100.0	100.0	100.0	100.0	100.0	100.0	100.0	100.0
20.06	100.0	100.0	100.0	100.0	100.0	100.0	100.0	100.0	100.0	100.0	100.0
19.78	100.0	100.0	100.0	100.0	100.0	100.0	100.0	100.0	100.0	100.0	100.0
19.50	100.0	100.0	100.0	100.0	100.0	100.0	100.0	100.0	100.0	100.0	100.0
19.22	100.0	100.0	100.0	100.0	100.0	100.0	100.0	100.0	100.0	100.0	100.0
18.94	100.0	100.0	100.0	100.0	100.0	100.0	100.0	100.0	100.0	100.0	100.0
18.66	100.0	100.0	100.0	100.0	100.0	100.0	100.0	100.0	100.0	100.0	100.0
18.38	100.0	100.0	100.0	100.0	100.0	100.0	100.0	100.0	100.0	100.0	100.0
18.17	100.0	100.0	100.0	100.0	100.0	100.0	100.0	100.0	100.0	100.0	100.0
18.03	100.0	100.0	100.0	100.0	100.0	100.0	100.0	100.0	100.0	100.0	100.0
17.82	100.0	100.0	100.0	100.0	100.0	100.0	100.0	100.0	100.0	100.0	100.0
17.54	100.0	100.0	100.0	100.0	100.0	100.0	100.0	100.0	100.0	100.0	100.0
17.26	100.0	100.0	100.0	100.0	100.0	100.0	100.0	100.0	100.0	100.0	100.0
17.00	100.0	100.0	100.0	100.0	100.0	100.0	100.0	100.0	100.0	100.0	100.0
16.86	100.0	100.0	100.0	100.0	100.0	100.0	100.0	100.0	100.0	100.0	100.0
16.70	100.0	100.0	100.0	100.0	100.0	100.0	100.0	100.0	100.0	100.0	100.0
16.44	100.0	100.0	100.0	100.0	100.0	100.0	100.0	100.0	100.0	100.0	100.0
16.30	100.0	100.0	100.0	100.0	100.0	100.0	100.0	100.0	100.0	100.0	100.0
16.14	100.0	100.0	100.0	100.0	100.0	100.0	100.0	100.0	100.0	100.0	100.0
15.86	100.0	100.0	100.0	100.0	100.0	100.0	100.0	100.0	100.0	100.0	100.0
15.58	100.0	100.0	100.0	100.0	100.0	100.0	100.0	100.0	100.0	100.0	100.0
15.30	100.0	100.0	100.0	100.0	100.0	100.0	100.0	100.0	100.0	100.0	100.0
15.02	100.0	100.0	100.0	100.0	100.0	100.0	100.0	100.0	100.0	100.0	100.0
14.74	100.0	100.0	100.0	100.0	100.0	100.0	100.0	100.0	100.0	100.0	100.0
14.46	100.0	100.0	100.0	100.0	100.0	100.0	100.0	100.0	100.0	100.0	100.0
14.18	100.0	100.0	100.0	100.0	100.0	100.0	100.0	100.0	100.0	100.0	100.0
13.90	100.0	100.0	100.0	100.0	100.0	100.0	100.0	100.0	100.0	100.0	100.0
13.62	100.0	100.0	100.0	100.0	100.0	100.0	100.0	100.0	100.0	100.0	100.0
13.34	100.0	100.0	100.0	100.0	100.0	100.0	100.0	100.0	100.0	100.0	100.0
13.18	100.0	100.0	100.0	100.0	100.0	100.0	100.0	100.0	100.0	100.0	100.0
13.04	100.0	100.0	100.0	100.0	100.0	100.0	100.0	100.0	100.0	100.0	100.0
12.78	100.0	100.0	100.0	100.0	100.0	100.0	100.0	100.0	100.0	100.0	100.0
12.57	100.0	100.0	100.0	100.0	100.0	100.0	100.0	100.0	100.0	100.0	100.0

Table H4. Percentage of time the 7-day moving average of daily maximum simulated August 1994 water temperatures exceeds 17.8 degrees Celsius along the main stem of the Tualatin River for each scenario—Continued

River mile	Scenario:										
	1	2	3	4a	4b	5	6	7	8	9	10
12.43	100.0	100.0	100.0	100.0	100.0	100.0	100.0	100.0	100.0	100.0	100.0
12.22	100.0	100.0	100.0	100.0	100.0	100.0	100.0	100.0	100.0	100.0	100.0
12.04	100.0	100.0	100.0	100.0	100.0	100.0	100.0	100.0	100.0	100.0	100.0
11.90	100.0	100.0	100.0	100.0	100.0	100.0	100.0	100.0	100.0	100.0	100.0
11.66	100.0	100.0	100.0	100.0	100.0	100.0	100.0	100.0	100.0	100.0	100.0
11.38	100.0	100.0	100.0	100.0	100.0	100.0	100.0	100.0	100.0	100.0	100.0
11.10	100.0	100.0	100.0	100.0	100.0	100.0	100.0	100.0	100.0	100.0	100.0
10.89	100.0	100.0	100.0	100.0	100.0	100.0	100.0	100.0	100.0	100.0	100.0
10.75	100.0	100.0	100.0	100.0	100.0	100.0	100.0	100.0	100.0	100.0	100.0
10.54	100.0	100.0	100.0	100.0	100.0	100.0	100.0	100.0	100.0	100.0	100.0
10.26	100.0	100.0	100.0	100.0	100.0	100.0	100.0	100.0	100.0	100.0	100.0
9.98	100.0	100.0	100.0	100.0	100.0	100.0	100.0	100.0	100.0	100.0	100.0
9.70	100.0	100.0	100.0	100.0	100.0	100.0	100.0	100.0	100.0	100.0	100.0
9.42	100.0	100.0	100.0	100.0	100.0	100.0	100.0	100.0	100.0	100.0	100.0
9.14	100.0	100.0	100.0	100.0	100.0	100.0	100.0	100.0	100.0	100.0	100.0
8.86	100.0	100.0	100.0	100.0	100.0	100.0	100.0	100.0	100.0	100.0	100.0
8.58	100.0	100.0	100.0	100.0	100.0	100.0	100.0	100.0	100.0	100.0	100.0
8.30	100.0	100.0	100.0	100.0	100.0	100.0	100.0	100.0	100.0	100.0	100.0
8.02	100.0	100.0	100.0	100.0	100.0	100.0	100.0	100.0	100.0	100.0	100.0
7.74	100.0	100.0	100.0	100.0	100.0	100.0	100.0	100.0	100.0	100.0	100.0
7.46	100.0	100.0	100.0	100.0	100.0	100.0	100.0	100.0	100.0	100.0	100.0
7.25	100.0	100.0	100.0	100.0	100.0	100.0	100.0	100.0	100.0	100.0	100.0
7.11	100.0	100.0	100.0	100.0	100.0	100.0	100.0	100.0	100.0	100.0	100.0
6.90	100.0	100.0	100.0	100.0	100.0	100.0	100.0	100.0	100.0	100.0	100.0
6.62	100.0	100.0	100.0	100.0	100.0	100.0	100.0	100.0	100.0	100.0	100.0
6.34	100.0	100.0	100.0	100.0	100.0	100.0	100.0	100.0	100.0	100.0	100.0
6.13	100.0	100.0	100.0	100.0	100.0	100.0	100.0	100.0	100.0	100.0	100.0
5.99	100.0	100.0	100.0	100.0	100.0	100.0	100.0	100.0	100.0	100.0	100.0
5.81	100.0	100.0	100.0	100.0	100.0	100.0	100.0	100.0	100.0	100.0	100.0
5.67	100.0	100.0	100.0	100.0	100.0	100.0	100.0	100.0	100.0	100.0	100.0
5.57	100.0	100.0	100.0	100.0	100.0	100.0	100.0	100.0	100.0	100.0	100.0
5.43	100.0	100.0	100.0	100.0	100.0	100.0	100.0	100.0	100.0	100.0	100.0
5.34	100.0	100.0	100.0	100.0	100.0	100.0	100.0	100.0	100.0	100.0	100.0
5.20	100.0	100.0	100.0	100.0	100.0	100.0	100.0	100.0	100.0	100.0	100.0
5.01	100.0	100.0	100.0	100.0	100.0	100.0	100.0	100.0	100.0	100.0	100.0
4.87	100.0	100.0	100.0	100.0	100.0	100.0	100.0	100.0	100.0	100.0	100.0
4.66	100.0	100.0	100.0	100.0	100.0	100.0	100.0	100.0	100.0	100.0	100.0
4.38	100.0	100.0	100.0	100.0	100.0	100.0	100.0	100.0	100.0	100.0	100.0
4.17	100.0	100.0	100.0	100.0	100.0	100.0	100.0	100.0	100.0	100.0	100.0
4.03	100.0	100.0	100.0	100.0	100.0	100.0	100.0	100.0	100.0	100.0	100.0
3.82	100.0	100.0	100.0	100.0	100.0	100.0	100.0	100.0	100.0	100.0	100.0

Table H5. Percentage of time the 7-day moving average of daily maximum simulated September 1994 water temperatures exceeds 17.8 degrees Celsius along the main stem of the Tualatin River for each scenario

River mile	Scenario:										
	1	2	3	4a	4b	5	6	7	8	9	10
63.90	43.3	43.3	43.3	43.3	43.3	43.3	0.0	43.3	43.3	43.3	0.0
63.75	43.3	43.3	33.3	43.3	43.3	43.3	0.0	43.3	43.3	43.3	0.0
63.50	33.3	33.3	10.0	33.3	33.3	33.3	0.0	33.3	33.3	33.3	0.0
63.00	13.3	13.3	0.0	13.3	13.3	13.3	0.0	13.3	13.3	13.3	0.0
62.50	0.0	0.0	0.0	10.0	0.0	0.0	0.0	0.0	0.0	0.0	0.0
62.25	10.0	10.0	0.0	33.3	0.0	10.0	0.0	10.0	10.0	10.0	0.0
62.00	16.7	16.7	0.0	43.3	0.0	16.7	0.0	16.7	16.7	16.7	0.0
61.90	20.0	20.0	0.0	43.3	0.0	20.0	0.0	20.0	20.0	20.0	0.0
61.50	23.3	23.3	0.0	56.7	0.0	23.3	0.0	23.3	23.3	23.3	0.0
61.00	23.3	23.3	0.0	56.7	0.0	23.3	0.0	23.3	23.3	23.3	0.0
60.50	16.7	16.7	0.0	50.0	0.0	16.7	0.0	16.7	16.7	16.7	0.0
60.00	0.0	0.0	0.0	0.0	0.0	0.0	0.0	0.0	0.0	0.0	0.0
59.60	0.0	0.0	0.0	0.0	0.0	0.0	0.0	0.0	0.0	0.0	0.0
59.35	0.0	0.0	0.0	0.0	0.0	0.0	0.0	0.0	0.0	0.0	0.0
59.10	0.0	0.0	0.0	0.0	0.0	0.0	0.0	0.0	0.0	0.0	0.0
58.90	0.0	0.0	0.0	0.0	0.0	0.0	0.0	0.0	0.0	0.0	0.0
58.50	0.0	0.0	0.0	0.0	0.0	0.0	0.0	0.0	0.0	0.0	0.0
58.30	0.0	0.0	0.0	0.0	0.0	0.0	0.0	0.0	0.0	0.0	0.0
58.00	0.0	0.0	0.0	0.0	0.0	0.0	0.0	0.0	0.0	0.0	0.0
57.70	0.0	0.0	0.0	0.0	0.0	0.0	0.0	0.0	0.0	0.0	0.0
57.50	0.0	0.0	0.0	0.0	0.0	0.0	0.0	0.0	0.0	0.0	0.0
57.25	0.0	0.0	0.0	0.0	0.0	0.0	0.0	0.0	0.0	0.0	0.0
57.00	0.0	0.0	0.0	0.0	0.0	0.0	0.0	0.0	0.0	0.0	0.0
56.70	0.0	0.0	0.0	0.0	0.0	0.0	0.0	0.0	0.0	0.0	0.0
56.55	0.0	0.0	0.0	0.0	0.0	0.0	0.0	0.0	0.0	0.0	0.0
56.45	0.0	0.0	0.0	0.0	0.0	0.0	0.0	0.0	0.0	0.0	0.0
56.30	0.0	0.0	0.0	0.0	0.0	0.0	0.0	0.0	0.0	0.0	0.0
56.00	0.0	0.0	0.0	0.0	0.0	0.0	0.0	0.0	0.0	0.0	0.0
55.80	0.0	0.0	0.0	0.0	0.0	0.0	0.0	0.0	0.0	0.0	0.0
55.60	0.0	0.0	0.0	0.0	0.0	0.0	0.0	0.0	0.0	0.0	0.0
55.20	0.0	0.0	0.0	0.0	0.0	0.0	0.0	0.0	0.0	0.0	0.0
55.00	0.0	0.0	0.0	0.0	0.0	0.0	0.0	0.0	0.0	0.0	0.0
54.90	0.0	0.0	0.0	0.0	0.0	0.0	0.0	0.0	0.0	0.0	0.0
54.70	0.0	0.0	0.0	0.0	0.0	0.0	0.0	0.0	0.0	0.0	0.0
54.50	0.0	0.0	0.0	0.0	0.0	0.0	0.0	0.0	0.0	0.0	0.0
54.10	0.0	0.0	0.0	0.0	0.0	0.0	0.0	0.0	0.0	0.0	0.0
54.00	0.0	0.0	0.0	0.0	0.0	0.0	0.0	0.0	0.0	0.0	0.0
53.80	0.0	0.0	0.0	0.0	0.0	0.0	0.0	0.0	0.0	0.0	0.0
53.60	0.0	0.0	0.0	0.0	0.0	0.0	0.0	0.0	0.0	0.0	0.0
53.40	0.0	0.0	0.0	0.0	0.0	0.0	0.0	0.0	0.0	0.0	0.0
53.05	0.0	0.0	0.0	0.0	0.0	0.0	0.0	0.0	0.0	0.0	0.0
52.90	0.0	0.0	0.0	0.0	0.0	0.0	0.0	0.0	0.0	0.0	0.0
52.30	0.0	0.0	0.0	3.3	0.0	0.0	0.0	0.0	0.0	0.0	0.0
52.15	0.0	0.0	0.0	3.3	0.0	0.0	0.0	0.0	0.0	0.0	0.0
52.00	0.0	0.0	0.0	6.7	0.0	0.0	0.0	0.0	0.0	0.0	0.0
51.70	0.0	51.7	0.0	16.7	0.0	0.0	0.0	0.0	0.0	0.0	0.0
51.40	0.0	0.0	0.0	20.0	0.0	0.0	0.0	0.0	0.0	0.0	0.0
51.05	0.0	0.0	0.0	20.0	0.0	0.0	0.0	0.0	0.0	0.0	0.0
50.85	0.0	0.0	0.0	20.0	0.0	0.0	0.0	0.0	0.0	0.0	0.0
50.65	0.0	0.0	0.0	20.0	0.0	0.0	0.0	0.0	0.0	0.0	0.0

Table H5. Percentage of time the 7-day moving average of daily maximum simulated September 1994 water temperatures exceeds 17.8 degrees Celsius along the main stem of the Tualatin River for each scenario—Continued

River mile	Scenario:										
	1	2	3	4a	4b	5	6	7	8	9	10
50.50	0.0	0.0	0.0	20.0	0.0	0.0	0.0	0.0	0.0	0.0	0.0
50.30	0.0	0.0	0.0	20.0	0.0	0.0	0.0	0.0	0.0	0.0	0.0
50.20	0.0	0.0	0.0	20.0	0.0	0.0	0.0	0.0	0.0	0.0	0.0
50.10	0.0	0.0	0.0	23.3	0.0	0.0	0.0	0.0	0.0	0.0	0.0
49.80	0.0	0.0	0.0	23.3	0.0	0.0	0.0	0.0	0.0	0.0	0.0
49.60	0.0	0.0	0.0	23.3	0.0	0.0	0.0	0.0	0.0	0.0	0.0
49.40	0.0	0.0	0.0	23.3	0.0	0.0	0.0	0.0	0.0	0.0	0.0
49.15	0.0	0.0	0.0	20.0	0.0	0.0	0.0	0.0	0.0	0.0	0.0
49.05	0.0	0.0	0.0	20.0	0.0	0.0	0.0	0.0	0.0	0.0	0.0
48.50	0.0	0.0	0.0	13.3	0.0	0.0	0.0	0.0	0.0	0.0	0.0
48.35	0.0	0.0	0.0	3.3	0.0	0.0	0.0	0.0	0.0	0.0	0.0
48.00	0.0	0.0	0.0	0.0	0.0	0.0	0.0	0.0	0.0	0.0	0.0
47.70	0.0	0.0	0.0	0.0	0.0	0.0	0.0	0.0	0.0	0.0	0.0
47.00	0.0	0.0	0.0	0.0	0.0	0.0	0.0	0.0	0.0	0.0	0.0
46.85	0.0	0.0	0.0	0.0	0.0	0.0	0.0	0.0	0.0	0.0	0.0
46.55	0.0	0.0	0.0	3.3	0.0	0.0	0.0	0.0	0.0	0.0	0.0
46.40	0.0	0.0	0.0	20.0	0.0	0.0	0.0	0.0	0.0	0.0	0.0
46.00	0.0	0.0	0.0	23.3	0.0	0.0	0.0	0.0	0.0	0.0	0.0
45.50	0.0	0.0	0.0	23.3	0.0	0.0	0.0	0.0	0.0	0.0	0.0
45.35	0.0	0.0	0.0	23.3	0.0	0.0	0.0	0.0	0.0	0.0	0.0
45.20	0.0	0.0	0.0	23.3	0.0	0.0	0.0	0.0	0.0	0.0	0.0
44.80	0.0	3.3	0.0	26.7	0.0	0.0	0.0	0.0	3.3	0.0	0.0
44.10	0.0	10.0	0.0	26.7	0.0	0.0	0.0	0.0	10.0	0.0	0.0
43.90	0.0	10.0	0.0	26.7	0.0	0.0	0.0	0.0	10.0	0.0	0.0
43.70	0.0	16.7	0.0	26.7	0.0	0.0	0.0	0.0	16.7	0.0	0.0
43.50	0.0	16.7	0.0	26.7	0.0	0.0	0.0	0.0	16.7	0.0	0.0
43.05	0.0	16.7	0.0	26.7	0.0	0.0	0.0	0.0	16.7	0.0	0.0
42.70	0.0	13.3	0.0	26.7	0.0	0.0	0.0	0.0	13.3	0.0	0.0
42.50	0.0	13.3	0.0	26.7	0.0	0.0	0.0	0.0	13.3	0.0	0.0
41.90	0.0	13.3	0.0	30.0	0.0	0.0	0.0	0.0	13.3	0.0	0.0
41.50	0.0	13.3	0.0	30.0	0.0	0.0	0.0	0.0	13.3	0.0	0.0
41.00	0.0	13.3	0.0	30.0	0.0	0.0	0.0	0.0	13.3	0.0	0.0
40.60	0.0	13.3	0.0	30.0	0.0	0.0	0.0	0.0	13.3	0.0	0.0
40.40	0.0	20.0	0.0	30.0	0.0	0.0	0.0	0.0	20.0	0.0	0.0
40.00	0.0	20.0	0.0	30.0	0.0	0.0	0.0	0.0	20.0	0.0	0.0
39.75	0.0	20.0	0.0	30.0	0.0	0.0	0.0	0.0	20.0	0.0	0.0
39.50	3.3	20.0	0.0	30.0	0.0	3.3	0.0	3.3	20.0	3.3	0.0
39.00	3.3	20.0	0.0	30.0	0.0	3.3	0.0	3.3	20.0	3.3	0.0
38.80	3.3	20.0	0.0	30.0	0.0	3.3	0.0	3.3	20.0	3.3	0.0
38.40	0.0	0.0	0.0	30.0	0.0	0.0	0.0	3.3	20.0	3.3	0.0
37.98	40.0	70.0	0.0	70.0	0.0	36.7	0.0	3.3	20.0	3.3	0.0
37.70	50.0	83.3	0.0	83.3	0.0	50.0	0.0	3.3	20.0	3.3	0.0
37.42	50.0	83.3	0.0	86.7	0.0	50.0	0.0	3.3	20.0	3.3	0.0
37.14	46.7	83.3	0.0	93.3	0.0	46.7	0.0	3.3	20.0	3.3	0.0
36.86	50.0	86.7	0.0	93.3	0.0	50.0	0.0	3.3	23.3	3.3	0.0
36.58	46.7	83.3	0.0	93.3	0.0	50.0	0.0	6.7	26.7	6.7	0.0
36.30	50.0	83.3	0.0	100.0	0.0	50.0	0.0	6.7	26.7	6.7	0.0
36.02	53.3	83.3	0.0	100.0	0.0	53.3	0.0	13.3	30.0	13.3	0.0
35.74	53.3	83.3	0.0	100.0	0.0	53.3	0.0	13.3	30.0	13.3	0.0
35.46	53.3	83.3	0.0	100.0	0.0	53.3	0.0	13.3	23.3	10.0	0.0

Table H5.Percentage of time the 7-day moving average of daily maximum simulated September 1994 water temperatures exceeds 17.8 degrees Celsius along the main stem of the Tualatin River for each scenario—Continued

River mile	Scenario:										
	1	2	3	4a	4b	5	6	7	8	9	10
35.18	53.3	83.3	0.0	100.0	10.0	53.3	0.0	13.3	26.7	13.3	0.0
34.90	53.3	83.3	0.0	100.0	16.7	53.3	0.0	13.3	30.0	10.0	0.0
34.62	56.7	83.3	0.0	100.0	13.3	56.7	0.0	20.0	30.0	20.0	0.0
34.34	50.0	76.7	0.0	100.0	0.0	53.3	0.0	20.0	30.0	20.0	0.0
34.06	50.0	76.7	0.0	100.0	0.0	50.0	0.0	23.3	33.3	23.3	0.0
33.78	50.0	70.0	0.0	100.0	0.0	46.7	0.0	16.7	20.0	16.7	0.0
33.50	43.3	66.7	0.0	100.0	0.0	46.7	0.0	20.0	23.3	23.3	0.0
33.22	40.0	60.0	0.0	100.0	0.0	43.3	0.0	20.0	23.3	23.3	0.0
32.94	40.0	56.7	0.0	100.0	0.0	40.0	0.0	16.7	23.3	20.0	0.0
32.66	40.0	56.7	0.0	100.0	0.0	40.0	0.0	16.7	26.7	23.3	0.0
32.38	43.3	66.7	0.0	100.0	0.0	43.3	0.0	23.3	30.0	23.3	0.0
32.10	46.7	73.3	0.0	100.0	0.0	46.7	0.0	26.7	46.7	26.7	0.0
31.82	50.0	80.0	0.0	100.0	0.0	53.3	0.0	30.0	50.0	30.0	0.0
31.54	56.7	80.0	0.0	100.0	0.0	56.7	0.0	33.3	56.7	30.0	0.0
31.26	60.0	83.3	0.0	100.0	0.0	60.0	20.0	40.0	56.7	36.7	0.0
30.98	63.3	83.3	0.0	96.7	0.0	60.0	20.0	33.3	43.3	30.0	0.0
30.70	63.3	83.3	0.0	96.7	0.0	63.3	23.3	36.7	50.0	30.0	0.0
30.42	66.7	83.3	0.0	96.7	0.0	66.7	23.3	36.7	53.3	36.7	0.0
30.14	66.7	83.3	0.0	96.7	0.0	73.3	26.7	40.0	60.0	36.7	0.0
29.86	66.7	83.3	0.0	96.7	0.0	70.0	26.7	36.7	60.0	33.3	0.0
29.58	70.0	83.3	0.0	96.7	0.0	70.0	26.7	36.7	60.0	30.0	0.0
29.30	70.0	83.3	0.0	100.0	0.0	73.3	30.0	33.3	63.3	30.0	0.0
29.02	73.3	83.3	0.0	100.0	6.7	73.3	33.3	43.3	66.7	36.7	0.0
28.74	70.0	83.3	0.0	100.0	0.0	73.3	26.7	36.7	66.7	33.3	0.0
28.46	70.0	76.7	0.0	100.0	3.3	73.3	26.7	36.7	63.3	33.3	0.0
28.24	46.7	63.3	0.0	90.0	0.0	36.7	0.0	23.3	36.7	20.0	0.0
28.10	60.0	76.7	0.0	96.7	0.0	53.3	16.7	33.3	56.7	26.7	0.0
27.90	56.7	76.7	0.0	93.3	0.0	46.7	20.0	33.3	60.0	26.7	0.0
27.62	60.0	80.0	0.0	100.0	0.0	56.7	26.7	43.3	73.3	40.0	0.0
27.34	66.7	83.3	0.0	100.0	10.0	60.0	30.0	50.0	73.3	50.0	23.3
27.09	63.3	80.0	0.0	93.3	0.0	60.0	26.7	40.0	66.7	40.0	0.0
26.95	63.3	80.0	0.0	93.3	0.0	60.0	26.7	43.3	66.7	40.0	0.0
26.85	66.7	80.0	0.0	100.0	0.0	63.3	30.0	46.7	66.7	46.7	6.7
26.71	66.7	80.0	3.3	100.0	0.0	63.3	30.0	50.0	70.0	43.3	3.3
26.50	73.3	80.0	3.3	100.0	6.7	70.0	40.0	53.3	73.3	50.0	13.3
26.29	76.7	83.3	3.3	100.0	23.3	73.3	46.7	60.0	73.3	53.3	20.0
26.15	66.7	80.0	3.3	100.0	0.0	66.7	30.0	50.0	66.7	40.0	0.0
25.94	73.3	83.3	30.0	100.0	16.7	73.3	43.3	56.7	73.3	53.3	23.3
25.73	76.7	86.7	23.3	100.0	20.0	76.7	43.3	63.3	80.0	53.3	26.7
25.59	76.7	86.7	23.3	100.0	20.0	76.7	43.3	63.3	76.7	53.3	26.7
25.38	76.7	86.7	23.3	100.0	20.0	76.7	43.3	63.3	76.7	56.7	26.7
25.10	76.7	83.3	20.0	100.0	20.0	73.3	43.3	63.3	76.7	56.7	23.3
24.91	76.7	86.7	23.3	100.0	26.7	76.7	53.3	66.7	80.0	63.3	33.3
24.80	70.0	83.3	13.3	100.0	13.3	70.0	40.0	53.3	76.7	53.3	23.3
24.72	73.3	86.7	36.7	100.0	23.3	76.7	50.0	66.7	80.0	63.3	33.3
24.54	76.7	86.7	33.3	100.0	23.3	76.7	50.0	66.7	80.0	60.0	33.3
24.26	76.7	86.7	40.0	100.0	30.0	76.7	53.3	70.0	83.3	66.7	36.7
24.05	76.7	90.0	36.7	100.0	36.7	76.7	56.7	73.3	83.3	70.0	43.3
23.91	76.7	86.7	33.3	100.0	26.7	76.7	53.3	70.0	80.0	63.3	40.0
23.70	76.7	90.0	43.3	100.0	33.3	76.7	56.7	73.3	83.3	70.0	40.0

Table H5. Percentage of time the 7-day moving average of daily maximum simulated September 1994 water temperatures exceeds 17.8 degrees Celsius along the main stem of the Tualatin River for each scenario—Continued

River mile	Scenario:										
	1	2	3	4a	4b	5	6	7	8	9	10
23.42	70.0	83.3	26.7	100.0	13.3	70.0	43.3	60.0	73.3	56.7	26.7
23.23	76.7	86.7	50.0	100.0	36.7	76.7	56.7	70.0	83.3	70.0	46.7
23.15	73.3	83.3	23.3	100.0	20.0	73.3	50.0	66.7	80.0	60.0	36.7
23.09	73.3	83.3	30.0	100.0	20.0	73.3	53.3	66.7	80.0	60.0	36.7
23.03	80.0	93.3	56.7	100.0	36.7	76.7	63.3	76.7	86.7	70.0	53.3
22.86	80.0	90.0	53.3	100.0	36.7	76.7	63.3	73.3	83.3	70.0	53.3
22.58	80.0	93.3	60.0	100.0	43.3	80.0	66.7	76.7	86.7	70.0	53.3
22.30	80.0	90.0	56.7	100.0	43.3	80.0	66.7	73.3	83.3	70.0	53.3
22.02	80.0	90.0	53.3	100.0	43.3	80.0	66.7	73.3	83.3	73.3	53.3
21.82	73.3	80.0	36.7	100.0	26.7	73.3	50.0	66.7	76.7	63.3	36.7
21.68	80.0	86.7	53.3	100.0	40.0	80.0	60.0	73.3	83.3	70.0	50.0
21.46	76.7	86.7	53.3	100.0	36.7	73.3	56.7	73.3	83.3	66.7	50.0
21.25	80.0	86.7	63.3	100.0	43.3	80.0	63.3	73.3	86.7	70.0	53.3
21.11	80.0	93.3	66.7	100.0	43.3	80.0	66.7	73.3	90.0	70.0	56.7
20.90	80.0	93.3	63.3	100.0	50.0	80.0	66.7	73.3	90.0	73.3	60.0
20.69	80.0	90.0	63.3	100.0	46.7	80.0	66.7	76.7	86.7	73.3	63.3
20.55	80.0	90.0	56.7	100.0	46.7	80.0	66.7	76.7	86.7	73.3	60.0
20.34	76.7	86.7	53.3	100.0	43.3	76.7	63.3	73.3	83.3	70.0	56.7
20.06	76.7	86.7	56.7	100.0	40.0	73.3	63.3	70.0	80.0	70.0	53.3
19.78	76.7	86.7	60.0	100.0	46.7	76.7	63.3	73.3	83.3	70.0	56.7
19.50	80.0	90.0	63.3	100.0	50.0	80.0	66.7	73.3	86.7	73.3	63.3
19.22	80.0	90.0	63.3	100.0	50.0	76.7	66.7	73.3	86.7	73.3	60.0
18.94	80.0	90.0	63.3	100.0	50.0	76.7	66.7	76.7	86.7	70.0	60.0
18.66	83.3	90.0	66.7	100.0	53.3	76.7	70.0	76.7	86.7	73.3	66.7
18.38	83.3	90.0	66.7	100.0	50.0	76.7	70.0	76.7	86.7	70.0	66.7
18.17	83.3	93.3	70.0	100.0	60.0	80.0	73.3	76.7	90.0	76.7	66.7
18.03	83.3	93.3	66.7	100.0	56.7	80.0	73.3	76.7	90.0	76.7	66.7
17.82	80.0	86.7	63.3	100.0	50.0	76.7	66.7	73.3	86.7	70.0	63.3
17.54	80.0	90.0	66.7	100.0	53.3	76.7	70.0	76.7	86.7	76.7	63.3
17.26	80.0	90.0	63.3	100.0	60.0	76.7	70.0	73.3	90.0	73.3	66.7
17.00	73.3	83.3	56.7	100.0	43.3	73.3	63.3	70.0	83.3	66.7	56.7
16.86	80.0	86.7	70.0	100.0	56.7	76.7	70.0	73.3	86.7	76.7	63.3
16.70	80.0	93.3	73.3	100.0	63.3	76.7	70.0	76.7	93.3	76.7	70.0
16.44	80.0	90.0	70.0	100.0	56.7	76.7	70.0	73.3	90.0	73.3	66.7
16.30	80.0	93.3	70.0	100.0	60.0	80.0	70.0	76.7	93.3	76.7	70.0
16.14	83.3	100.0	73.3	100.0	60.0	80.0	70.0	80.0	100.0	76.7	70.0
15.86	83.3	100.0	73.3	100.0	66.7	83.3	76.7	80.0	100.0	80.0	73.3
15.58	83.3	100.0	70.0	100.0	63.3	80.0	73.3	80.0	93.3	73.3	73.3
15.30	80.0	86.7	66.7	100.0	60.0	80.0	73.3	76.7	86.7	73.3	66.7
15.02	80.0	90.0	73.3	100.0	60.0	80.0	73.3	76.7	93.3	73.3	66.7
14.74	80.0	93.3	73.3	100.0	63.3	80.0	73.3	80.0	96.7	73.3	70.0
14.46	83.3	100.0	76.7	100.0	70.0	83.3	76.7	80.0	100.0	80.0	73.3
14.18	83.3	90.0	70.0	100.0	63.3	80.0	73.3	76.7	90.0	76.7	70.0
13.90	83.3	93.3	73.3	100.0	63.3	80.0	73.3	80.0	93.3	80.0	70.0
13.62	86.7	93.3	70.0	100.0	63.3	80.0	73.3	80.0	93.3	76.7	70.0
13.34	76.7	83.3	66.7	100.0	60.0	76.7	70.0	73.3	83.3	70.0	63.3
13.18	80.0	90.0	76.7	100.0	63.3	76.7	70.0	76.7	86.7	76.7	70.0
13.04	80.0	93.3	76.7	100.0	63.3	76.7	73.3	76.7	93.3	76.7	70.0
12.78	83.3	100.0	76.7	100.0	66.7	80.0	73.3	80.0	100.0	76.7	70.0
12.57	86.7	100.0	76.7	100.0	70.0	80.0	80.0	80.0	100.0	80.0	73.3

Table H5. Percentage of time the 7-day moving average of daily maximum simulated September 1994 water temperatures exceeds 17.8 degrees Celsius along the main stem of the Tualatin River for each scenario—Continued

River mile	Scenario:										
	1	2	3	4a	4b	5	6	7	8	9	10
12.43	90.0	100.0	76.7	100.0	70.0	83.3	80.0	86.7	100.0	80.0	76.7
12.22	86.7	96.7	76.7	100.0	66.7	80.0	73.3	80.0	93.3	76.7	70.0
12.04	86.7	100.0	80.0	100.0	70.0	80.0	76.7	80.0	100.0	80.0	73.3
11.90	90.0	100.0	80.0	100.0	73.3	83.3	80.0	86.7	100.0	80.0	76.7
11.66	90.0	100.0	80.0	100.0	73.3	86.7	80.0	86.7	100.0	83.3	76.7
11.38	90.0	100.0	80.0	100.0	73.3	86.7	80.0	86.7	100.0	86.7	76.7
11.10	90.0	100.0	80.0	100.0	73.3	86.7	80.0	86.7	100.0	83.3	76.7
10.89	86.7	100.0	76.7	100.0	73.3	83.3	80.0	83.3	100.0	83.3	76.7
10.75	86.7	100.0	76.7	100.0	70.0	83.3	76.7	83.3	100.0	80.0	76.7
10.54	86.7	100.0	76.7	100.0	70.0	83.3	76.7	83.3	100.0	76.7	73.3
10.26	80.0	86.7	73.3	100.0	63.3	76.7	73.3	73.3	90.0	73.3	70.0
9.98	100.0	100.0	100.0	100.0	76.7	86.7	83.3	100.0	100.0	90.0	83.3
9.70	90.0	100.0	100.0	100.0	73.3	100.0	80.0	100.0	100.0	96.7	86.7
9.42	100.0	100.0	100.0	100.0	90.0	100.0	100.0	100.0	100.0	100.0	86.7
9.14	100.0	100.0	100.0	100.0	96.7	100.0	100.0	100.0	100.0	100.0	83.3
8.86	100.0	100.0	100.0	100.0	93.3	100.0	100.0	96.7	100.0	100.0	80.0
8.58	100.0	100.0	100.0	100.0	96.7	100.0	100.0	96.7	100.0	100.0	83.3
8.30	100.0	100.0	100.0	100.0	90.0	100.0	100.0	90.0	100.0	100.0	80.0
8.02	100.0	100.0	100.0	100.0	83.3	100.0	93.3	86.7	100.0	100.0	76.7
7.74	100.0	100.0	100.0	100.0	86.7	100.0	100.0	90.0	100.0	100.0	83.3
7.46	100.0	100.0	100.0	100.0	83.3	100.0	100.0	90.0	100.0	100.0	83.3
7.25	100.0	100.0	96.7	100.0	83.3	100.0	100.0	93.3	100.0	100.0	83.3
7.11	100.0	100.0	100.0	100.0	86.7	100.0	100.0	96.7	100.0	100.0	86.7
6.90	100.0	100.0	96.7	100.0	86.7	100.0	100.0	100.0	100.0	100.0	86.7
6.62	100.0	100.0	93.3	100.0	83.3	100.0	90.0	86.7	100.0	100.0	80.0
6.34	100.0	100.0	90.0	100.0	90.0	100.0	100.0	93.3	100.0	90.0	83.3
6.13	100.0	100.0	86.7	100.0	90.0	100.0	100.0	93.3	100.0	90.0	80.0
5.99	100.0	100.0	83.3	100.0	86.7	100.0	100.0	86.7	100.0	83.3	80.0
5.81	100.0	100.0	86.7	100.0	86.7	100.0	93.3	86.7	96.7	90.0	80.0
5.67	100.0	100.0	83.3	100.0	86.7	100.0	100.0	93.3	100.0	83.3	83.3
5.57	100.0	100.0	83.3	100.0	86.7	100.0	100.0	93.3	100.0	83.3	83.3
5.43	100.0	100.0	86.7	100.0	86.7	100.0	100.0	93.3	100.0	93.3	83.3
5.34	100.0	100.0	86.7	100.0	86.7	100.0	100.0	100.0	100.0	90.0	86.7
5.20	100.0	100.0	90.0	100.0	86.7	100.0	100.0	93.3	100.0	90.0	86.7
5.01	100.0	100.0	90.0	100.0	86.7	100.0	100.0	100.0	100.0	96.7	86.7
4.87	100.0	100.0	90.0	100.0	86.7	100.0	100.0	100.0	100.0	96.7	86.7
4.66	100.0	100.0	90.0	100.0	93.3	100.0	100.0	100.0	100.0	93.3	86.7
4.38	100.0	100.0	86.7	100.0	93.3	100.0	100.0	100.0	100.0	86.7	86.7
4.17	100.0	100.0	90.0	100.0	90.0	100.0	100.0	100.0	100.0	90.0	86.7
4.03	100.0	100.0	80.0	100.0	90.0	100.0	100.0	100.0	100.0	83.3	86.7
3.82	100.0	100.0	93.3	100.0	86.7	100.0	100.0	100.0	100.0	100.0	86.7

Table H6. Percentage of time the 7-day moving average of daily maximum simulated October 1994 water temperatures exceeds 17.8 degrees Celsius along the main stem of the Tualatin River for each scenario

River mile	Scenario:										
	1	2	3	4a	4b	5	6	7	8	9	10
63.90	0.0	0.0	0.0	0.0	0.0	0.0	0.0	0.0	0.0	0.0	0.0
63.75	0.0	0.0	0.0	0.0	0.0	0.0	0.0	0.0	0.0	0.0	0.0
63.50	0.0	0.0	0.0	0.0	0.0	0.0	0.0	0.0	0.0	0.0	0.0
63.00	0.0	0.0	0.0	0.0	0.0	0.0	0.0	0.0	0.0	0.0	0.0
62.50	0.0	0.0	0.0	0.0	0.0	0.0	0.0	0.0	0.0	0.0	0.0
62.25	0.0	0.0	0.0	0.0	0.0	0.0	0.0	0.0	0.0	0.0	0.0
62.00	0.0	0.0	0.0	0.0	0.0	0.0	0.0	0.0	0.0	0.0	0.0
61.90	0.0	0.0	0.0	0.0	0.0	0.0	0.0	0.0	0.0	0.0	0.0
61.50	0.0	0.0	0.0	0.0	0.0	0.0	0.0	0.0	0.0	0.0	0.0
61.00	0.0	0.0	0.0	0.0	0.0	0.0	0.0	0.0	0.0	0.0	0.0
60.50	0.0	0.0	0.0	0.0	0.0	0.0	0.0	0.0	0.0	0.0	0.0
60.00	0.0	0.0	0.0	0.0	0.0	0.0	0.0	0.0	0.0	0.0	0.0
59.60	0.0	0.0	0.0	0.0	0.0	0.0	0.0	0.0	0.0	0.0	0.0
59.35	0.0	0.0	0.0	0.0	0.0	0.0	0.0	0.0	0.0	0.0	0.0
59.10	0.0	0.0	0.0	0.0	0.0	0.0	0.0	0.0	0.0	0.0	0.0
58.90	0.0	0.0	0.0	0.0	0.0	0.0	0.0	0.0	0.0	0.0	0.0
58.50	0.0	0.0	0.0	0.0	0.0	0.0	0.0	0.0	0.0	0.0	0.0
58.30	0.0	0.0	0.0	0.0	0.0	0.0	0.0	0.0	0.0	0.0	0.0
58.00	0.0	0.0	0.0	0.0	0.0	0.0	0.0	0.0	0.0	0.0	0.0
57.70	0.0	0.0	0.0	0.0	0.0	0.0	0.0	0.0	0.0	0.0	0.0
57.50	0.0	0.0	0.0	0.0	0.0	0.0	0.0	0.0	0.0	0.0	0.0
57.25	0.0	0.0	0.0	0.0	0.0	0.0	0.0	0.0	0.0	0.0	0.0
57.00	0.0	0.0	0.0	0.0	0.0	0.0	0.0	0.0	0.0	0.0	0.0
56.70	0.0	0.0	0.0	0.0	0.0	0.0	0.0	0.0	0.0	0.0	0.0
56.55	0.0	0.0	0.0	0.0	0.0	0.0	0.0	0.0	0.0	0.0	0.0
56.45	0.0	0.0	0.0	0.0	0.0	0.0	0.0	0.0	0.0	0.0	0.0
56.30	0.0	0.0	0.0	0.0	0.0	0.0	0.0	0.0	0.0	0.0	0.0
56.00	0.0	0.0	0.0	0.0	0.0	0.0	0.0	0.0	0.0	0.0	0.0
55.80	0.0	0.0	0.0	0.0	0.0	0.0	0.0	0.0	0.0	0.0	0.0
55.60	0.0	0.0	0.0	0.0	0.0	0.0	0.0	0.0	0.0	0.0	0.0
55.20	0.0	0.0	0.0	0.0	0.0	0.0	0.0	0.0	0.0	0.0	0.0
55.00	0.0	0.0	0.0	0.0	0.0	0.0	0.0	0.0	0.0	0.0	0.0
54.90	0.0	0.0	0.0	0.0	0.0	0.0	0.0	0.0	0.0	0.0	0.0
54.70	0.0	0.0	0.0	0.0	0.0	0.0	0.0	0.0	0.0	0.0	0.0
54.50	0.0	0.0	0.0	0.0	0.0	0.0	0.0	0.0	0.0	0.0	0.0
54.10	0.0	0.0	0.0	0.0	0.0	0.0	0.0	0.0	0.0	0.0	0.0
54.00	0.0	0.0	0.0	0.0	0.0	0.0	0.0	0.0	0.0	0.0	0.0
53.80	0.0	0.0	0.0	0.0	0.0	0.0	0.0	0.0	0.0	0.0	0.0
53.60	0.0	0.0	0.0	0.0	0.0	0.0	0.0	0.0	0.0	0.0	0.0
53.40	0.0	0.0	0.0	0.0	0.0	0.0	0.0	0.0	0.0	0.0	0.0
53.05	0.0	0.0	0.0	0.0	0.0	0.0	0.0	0.0	0.0	0.0	0.0
52.90	0.0	0.0	0.0	0.0	0.0	0.0	0.0	0.0	0.0	0.0	0.0
52.30	0.0	0.0	0.0	0.0	0.0	0.0	0.0	0.0	0.0	0.0	0.0
52.15	0.0	0.0	0.0	0.0	0.0	0.0	0.0	0.0	0.0	0.0	0.0
52.00	0.0	0.0	0.0	0.0	0.0	0.0	0.0	0.0	0.0	0.0	0.0
51.70	0.0	0.0	0.0	0.0	0.0	0.0	0.0	0.0	0.0	0.0	0.0
51.40	0.0	0.0	0.0	0.0	0.0	0.0	0.0	0.0	0.0	0.0	0.0
51.05	0.0	0.0	0.0	0.0	0.0	0.0	0.0	0.0	0.0	0.0	0.0
50.85	0.0	0.0	0.0	0.0	0.0	0.0	0.0	0.0	0.0	0.0	0.0
50.65	0.0	0.0	0.0	0.0	0.0	0.0	0.0	0.0	0.0	0.0	0.0

Table H6. Percentage of time the 7-day moving average of daily maximum simulated October 1994 water temperatures exceeds 17.8 degrees Celsius along the main stem of the Tualatin River for each scenario—Continued

River mile	Scenario:										
	1	2	3	4a	4b	5	6	7	8	9	10
50.50	0.0	0.0	0.0	0.0	0.0	0.0	0.0	0.0	0.0	0.0	0.0
50.30	0.0	0.0	0.0	0.0	0.0	0.0	0.0	0.0	0.0	0.0	0.0
50.20	0.0	0.0	0.0	0.0	0.0	0.0	0.0	0.0	0.0	0.0	0.0
50.10	0.0	0.0	0.0	0.0	0.0	0.0	0.0	0.0	0.0	0.0	0.0
49.80	0.0	0.0	0.0	0.0	0.0	0.0	0.0	0.0	0.0	0.0	0.0
49.60	0.0	0.0	0.0	0.0	0.0	0.0	0.0	0.0	0.0	0.0	0.0
49.40	0.0	0.0	0.0	0.0	0.0	0.0	0.0	0.0	0.0	0.0	0.0
49.15	0.0	0.0	0.0	0.0	0.0	0.0	0.0	0.0	0.0	0.0	0.0
49.05	0.0	0.0	0.0	0.0	0.0	0.0	0.0	0.0	0.0	0.0	0.0
48.50	0.0	0.0	0.0	0.0	0.0	0.0	0.0	0.0	0.0	0.0	0.0
48.35	0.0	0.0	0.0	0.0	0.0	0.0	0.0	0.0	0.0	0.0	0.0
48.00	0.0	0.0	0.0	0.0	0.0	0.0	0.0	0.0	0.0	0.0	0.0
47.70	0.0	0.0	0.0	0.0	0.0	0.0	0.0	0.0	0.0	0.0	0.0
47.00	0.0	0.0	0.0	0.0	0.0	0.0	0.0	0.0	0.0	0.0	0.0
46.85	0.0	0.0	0.0	0.0	0.0	0.0	0.0	0.0	0.0	0.0	0.0
46.55	0.0	0.0	0.0	0.0	0.0	0.0	0.0	0.0	0.0	0.0	0.0
46.40	0.0	0.0	0.0	0.0	0.0	0.0	0.0	0.0	0.0	0.0	0.0
46.00	0.0	0.0	0.0	0.0	0.0	0.0	0.0	0.0	0.0	0.0	0.0
45.50	0.0	0.0	0.0	0.0	0.0	0.0	0.0	0.0	0.0	0.0	0.0
45.35	0.0	0.0	0.0	0.0	0.0	0.0	0.0	0.0	0.0	0.0	0.0
45.20	0.0	0.0	0.0	0.0	0.0	0.0	0.0	0.0	0.0	0.0	0.0
44.80	0.0	0.0	0.0	0.0	0.0	0.0	0.0	0.0	0.0	0.0	0.0
44.10	0.0	0.0	0.0	0.0	0.0	0.0	0.0	0.0	0.0	0.0	0.0
43.90	0.0	0.0	0.0	0.0	0.0	0.0	0.0	0.0	0.0	0.0	0.0
43.70	0.0	0.0	0.0	0.0	0.0	0.0	0.0	0.0	0.0	0.0	0.0
43.50	0.0	0.0	0.0	0.0	0.0	0.0	0.0	0.0	0.0	0.0	0.0
43.05	0.0	0.0	0.0	0.0	0.0	0.0	0.0	0.0	0.0	0.0	0.0
42.70	0.0	0.0	0.0	0.0	0.0	0.0	0.0	0.0	0.0	0.0	0.0
42.50	0.0	0.0	0.0	0.0	0.0	0.0	0.0	0.0	0.0	0.0	0.0
41.90	0.0	0.0	0.0	0.0	0.0	0.0	0.0	0.0	0.0	0.0	0.0
41.50	0.0	0.0	0.0	0.0	0.0	0.0	0.0	0.0	0.0	0.0	0.0
41.00	0.0	0.0	0.0	0.0	0.0	0.0	0.0	0.0	0.0	0.0	0.0
40.60	0.0	0.0	0.0	0.0	0.0	0.0	0.0	0.0	0.0	0.0	0.0
40.40	0.0	0.0	0.0	0.0	0.0	0.0	0.0	0.0	0.0	0.0	0.0
40.00	0.0	0.0	0.0	0.0	0.0	0.0	0.0	0.0	0.0	0.0	0.0
39.75	0.0	0.0	0.0	0.0	0.0	0.0	0.0	0.0	0.0	0.0	0.0
39.50	0.0	0.0	0.0	0.0	0.0	0.0	0.0	0.0	0.0	0.0	0.0
39.00	0.0	0.0	0.0	0.0	0.0	0.0	0.0	0.0	0.0	0.0	0.0
38.80	0.0	0.0	0.0	0.0	0.0	0.0	0.0	0.0	0.0	0.0	0.0
38.40	0.0	0.0	0.0	0.0	0.0	0.0	0.0	0.0	0.0	0.0	0.0
37.98	0.0	3.2	0.0	0.0	0.0	0.0	0.0	0.0	0.0	0.0	0.0
37.70	0.0	16.1	0.0	3.2	0.0	0.0	0.0	0.0	0.0	0.0	0.0
37.42	0.0	19.4	0.0	6.5	0.0	0.0	0.0	0.0	0.0	0.0	0.0
37.14	0.0	22.6	0.0	9.7	0.0	0.0	0.0	0.0	0.0	0.0	0.0
36.86	3.2	25.8	0.0	12.9	0.0	3.2	0.0	0.0	0.0	0.0	0.0
36.58	3.2	22.6	0.0	16.1	0.0	3.2	0.0	0.0	0.0	0.0	0.0
36.30	3.2	19.4	0.0	16.1	0.0	3.2	0.0	0.0	0.0	0.0	0.0
36.02	0.0	22.6	0.0	9.7	0.0	0.0	0.0	0.0	0.0	0.0	0.0
35.74	0.0	22.6	0.0	12.9	0.0	0.0	0.0	0.0	0.0	0.0	0.0
35.46	3.2	16.1	0.0	16.1	0.0	3.2	0.0	0.0	0.0	0.0	0.0

Table H6. Percentage of time the 7-day moving average of daily maximum simulated October 1994 water temperatures exceeds 17.8 degrees Celsius along the main stem of the Tualatin River for each scenario—Continued

River mile	Scenario:										
	1	2	3	4a	4b	5	6	7	8	9	10
35.18	3.2	16.1	0.0	16.1	0.0	3.2	0.0	0.0	0.0	0.0	0.0
34.90	3.2	12.9	0.0	16.1	0.0	3.2	0.0	0.0	0.0	0.0	0.0
34.62	3.2	9.7	0.0	12.9	0.0	3.2	0.0	0.0	0.0	0.0	0.0
34.34	0.0	6.5	0.0	12.9	0.0	0.0	0.0	0.0	0.0	0.0	0.0
34.06	0.0	6.5	0.0	9.7	0.0	0.0	0.0	0.0	0.0	0.0	0.0
33.78	0.0	3.2	0.0	9.7	0.0	0.0	0.0	0.0	0.0	0.0	0.0
33.50	0.0	3.2	0.0	6.5	0.0	0.0	0.0	0.0	0.0	0.0	0.0
33.22	0.0	0.0	0.0	6.5	0.0	0.0	0.0	0.0	0.0	0.0	0.0
32.94	0.0	0.0	0.0	6.5	0.0	0.0	0.0	0.0	0.0	0.0	0.0
32.66	0.0	3.2	0.0	6.5	0.0	0.0	0.0	0.0	0.0	0.0	0.0
32.38	0.0	3.2	0.0	6.5	0.0	0.0	0.0	0.0	0.0	0.0	0.0
32.10	0.0	3.2	0.0	6.5	0.0	0.0	0.0	0.0	0.0	0.0	0.0
31.82	0.0	3.2	0.0	6.5	0.0	0.0	0.0	0.0	0.0	0.0	0.0
31.54	0.0	3.2	0.0	6.5	0.0	0.0	0.0	0.0	0.0	0.0	0.0
31.26	0.0	3.2	0.0	6.5	0.0	0.0	0.0	0.0	0.0	0.0	0.0
30.98	0.0	3.2	0.0	3.2	0.0	0.0	0.0	0.0	0.0	0.0	0.0
30.70	0.0	3.2	0.0	3.2	0.0	0.0	0.0	0.0	0.0	0.0	0.0
30.42	0.0	3.2	0.0	3.2	0.0	0.0	0.0	0.0	0.0	0.0	0.0
30.14	0.0	3.2	0.0	3.2	0.0	0.0	0.0	0.0	0.0	0.0	0.0
29.86	0.0	0.0	0.0	3.2	0.0	0.0	0.0	0.0	0.0	0.0	0.0
29.58	0.0	0.0	0.0	6.5	0.0	0.0	0.0	0.0	0.0	0.0	0.0
29.30	0.0	0.0	0.0	6.5	0.0	0.0	0.0	0.0	0.0	0.0	0.0
29.02	0.0	3.2	0.0	6.5	0.0	0.0	0.0	0.0	0.0	0.0	0.0
28.74	0.0	3.2	0.0	6.5	0.0	0.0	0.0	0.0	0.0	0.0	0.0
28.46	0.0	3.2	0.0	6.5	0.0	0.0	0.0	0.0	0.0	0.0	0.0
28.24	0.0	0.0	0.0	3.2	0.0	0.0	0.0	0.0	0.0	0.0	0.0
28.10	0.0	0.0	0.0	3.2	0.0	0.0	0.0	0.0	0.0	0.0	0.0
27.90	0.0	3.2	0.0	3.2	0.0	0.0	0.0	0.0	0.0	0.0	0.0
27.62	0.0	3.2	0.0	6.5	0.0	0.0	0.0	0.0	0.0	0.0	0.0
27.34	0.0	3.2	0.0	6.5	0.0	0.0	0.0	0.0	0.0	0.0	0.0
27.09	0.0	3.2	0.0	6.5	0.0	0.0	0.0	0.0	0.0	0.0	0.0
26.95	0.0	3.2	0.0	6.5	0.0	0.0	0.0	0.0	0.0	0.0	0.0
26.85	0.0	3.2	0.0	6.5	0.0	0.0	0.0	0.0	0.0	0.0	0.0
26.71	0.0	3.2	0.0	6.5	0.0	0.0	0.0	0.0	0.0	0.0	0.0
26.50	0.0	3.2	0.0	6.5	0.0	0.0	0.0	0.0	0.0	0.0	0.0
26.29	0.0	3.2	0.0	6.5	0.0	0.0	0.0	0.0	0.0	0.0	0.0
26.15	0.0	3.2	0.0	6.5	0.0	0.0	0.0	0.0	0.0	0.0	0.0
25.94	0.0	3.2	0.0	6.5	0.0	0.0	0.0	0.0	3.2	0.0	0.0
25.73	0.0	3.2	0.0	6.5	0.0	0.0	0.0	0.0	3.2	0.0	0.0
25.59	0.0	3.2	0.0	6.5	0.0	0.0	0.0	0.0	3.2	0.0	0.0
25.38	3.2	3.2	0.0	6.5	0.0	0.0	0.0	0.0	3.2	0.0	0.0
25.10	3.2	3.2	0.0	6.5	0.0	0.0	0.0	0.0	3.2	0.0	0.0
24.91	3.2	3.2	0.0	6.5	0.0	0.0	0.0	0.0	3.2	0.0	0.0
24.80	0.0	3.2	0.0	6.5	0.0	0.0	0.0	0.0	3.2	0.0	0.0
24.72	3.2	3.2	0.0	6.5	0.0	0.0	0.0	0.0	3.2	0.0	0.0
24.54	3.2	3.2	0.0	6.5	0.0	0.0	0.0	0.0	3.2	0.0	0.0
24.26	3.2	6.5	0.0	9.7	0.0	3.2	0.0	0.0	3.2	0.0	0.0
24.05	3.2	6.5	0.0	9.7	0.0	3.2	0.0	0.0	3.2	0.0	0.0
23.91	3.2	6.5	0.0	9.7	0.0	3.2	0.0	0.0	3.2	0.0	0.0
23.70	3.2	6.5	0.0	9.7	0.0	3.2	0.0	0.0	3.2	0.0	0.0

Table H6. Percentage of time the 7-day moving average of daily maximum simulated October 1994 water temperatures exceeds 17.8 degrees Celsius along the main stem of the Tualatin River for each scenario—Continued

River mile	Scenario:										
	1	2	3	4a	4b	5	6	7	8	9	10
23.42	3.2	6.5	0.0	6.5	0.0	3.2	0.0	0.0	3.2	0.0	0.0
23.23	3.2	6.5	0.0	9.7	0.0	3.2	0.0	0.0	6.5	0.0	0.0
23.15	3.2	6.5	0.0	6.5	0.0	0.0	0.0	0.0	3.2	0.0	0.0
23.09	3.2	6.5	0.0	6.5	0.0	3.2	0.0	0.0	3.2	0.0	0.0
23.03	3.2	6.5	0.0	9.7	0.0	3.2	0.0	0.0	6.5	0.0	0.0
22.86	3.2	6.5	0.0	9.7	0.0	3.2	0.0	0.0	6.5	0.0	0.0
22.58	3.2	6.5	0.0	9.7	0.0	3.2	0.0	3.2	6.5	0.0	0.0
22.30	3.2	6.5	0.0	9.7	0.0	3.2	0.0	3.2	6.5	0.0	0.0
22.02	3.2	6.5	0.0	9.7	0.0	3.2	0.0	3.2	6.5	3.2	0.0
21.82	3.2	6.5	0.0	9.7	0.0	3.2	0.0	0.0	6.5	0.0	0.0
21.68	3.2	6.5	0.0	9.7	0.0	3.2	0.0	3.2	6.5	0.0	0.0
21.46	3.2	6.5	0.0	9.7	0.0	3.2	0.0	0.0	6.5	0.0	0.0
21.25	3.2	6.5	0.0	9.7	0.0	3.2	0.0	3.2	6.5	0.0	0.0
21.11	3.2	6.5	0.0	9.7	0.0	3.2	0.0	3.2	6.5	0.0	0.0
20.90	3.2	6.5	0.0	9.7	0.0	3.2	0.0	3.2	6.5	3.2	0.0
20.69	3.2	6.5	0.0	9.7	0.0	3.2	0.0	3.2	6.5	3.2	0.0
20.55	3.2	6.5	0.0	9.7	0.0	3.2	0.0	3.2	6.5	3.2	0.0
20.34	3.2	6.5	0.0	9.7	0.0	3.2	0.0	3.2	6.5	3.2	0.0
20.06	3.2	6.5	0.0	9.7	0.0	3.2	0.0	3.2	6.5	0.0	0.0
19.78	3.2	6.5	0.0	9.7	0.0	3.2	0.0	3.2	6.5	0.0	0.0
19.50	3.2	6.5	0.0	9.7	0.0	3.2	0.0	3.2	6.5	3.2	0.0
19.22	3.2	6.5	0.0	9.7	0.0	3.2	0.0	3.2	6.5	3.2	0.0
18.94	3.2	6.5	0.0	12.9	0.0	3.2	0.0	3.2	6.5	3.2	0.0
18.66	3.2	6.5	0.0	12.9	0.0	3.2	0.0	3.2	6.5	3.2	0.0
18.38	6.5	6.5	0.0	12.9	0.0	3.2	3.2	3.2	6.5	3.2	0.0
18.17	6.5	6.5	0.0	12.9	0.0	3.2	3.2	3.2	6.5	3.2	0.0
18.03	6.5	6.5	0.0	12.9	0.0	3.2	3.2	3.2	6.5	3.2	0.0
17.82	6.5	6.5	0.0	12.9	0.0	3.2	3.2	3.2	6.5	3.2	0.0
17.54	6.5	6.5	0.0	12.9	0.0	3.2	3.2	6.5	9.7	3.2	0.0
17.26	6.5	9.7	0.0	12.9	0.0	3.2	3.2	6.5	9.7	3.2	3.2
17.00	6.5	6.5	0.0	12.9	0.0	3.2	3.2	6.5	6.5	3.2	0.0
16.86	6.5	9.7	3.2	12.9	0.0	3.2	3.2	6.5	9.7	3.2	0.0
16.70	6.5	9.7	3.2	12.9	0.0	3.2	3.2	6.5	9.7	3.2	3.2
16.44	6.5	9.7	3.2	12.9	0.0	6.5	3.2	6.5	9.7	3.2	3.2
16.30	6.5	9.7	3.2	12.9	0.0	6.5	3.2	6.5	9.7	3.2	3.2
16.14	6.5	9.7	3.2	12.9	0.0	6.5	3.2	6.5	9.7	3.2	3.2
15.86	6.5	9.7	3.2	16.1	0.0	6.5	3.2	6.5	9.7	6.5	3.2
15.58	6.5	9.7	3.2	12.9	0.0	6.5	3.2	6.5	9.7	6.5	3.2
15.30	6.5	6.5	0.0	12.9	0.0	3.2	3.2	6.5	6.5	3.2	3.2
15.02	6.5	9.7	3.2	12.9	0.0	3.2	3.2	6.5	9.7	3.2	3.2
14.74	6.5	9.7	3.2	12.9	0.0	6.5	3.2	6.5	9.7	3.2	3.2
14.46	6.5	9.7	3.2	16.1	0.0	6.5	3.2	6.5	9.7	6.5	3.2
14.18	6.5	9.7	3.2	16.1	0.0	6.5	3.2	6.5	9.7	6.5	3.2
13.90	6.5	9.7	3.2	16.1	0.0	6.5	3.2	6.5	9.7	6.5	3.2
13.62	6.5	9.7	3.2	16.1	0.0	6.5	3.2	6.5	9.7	6.5	3.2
13.34	6.5	9.7	0.0	12.9	0.0	6.5	3.2	6.5	6.5	6.5	3.2
13.18	6.5	9.7	3.2	16.1	0.0	6.5	3.2	6.5	9.7	6.5	3.2
13.04	6.5	9.7	3.2	16.1	0.0	6.5	3.2	6.5	6.5	6.5	3.2
12.78	6.5	9.7	3.2	16.1	0.0	6.5	3.2	6.5	9.7	6.5	3.2
12.57	6.5	9.7	3.2	16.1	3.2	6.5	6.5	6.5	9.7	6.5	3.2

Table H6. Percentage of time the 7-day moving average of daily maximum simulated October 1994 water temperatures exceeds 17.8 degrees Celsius along the main stem of the Tualatin River for each scenario—Continued

River mile	Scenario:										
	1	2	3	4a	4b	5	6	7	8	9	10
12.43	6.5	9.7	3.2	16.1	3.2	6.5	6.5	6.5	9.7	6.5	3.2
12.22	6.5	9.7	3.2	16.1	3.2	6.5	6.5	6.5	9.7	6.5	3.2
12.04	6.5	9.7	3.2	16.1	3.2	6.5	6.5	6.5	9.7	6.5	3.2
11.90	6.5	9.7	3.2	16.1	3.2	6.5	6.5	6.5	9.7	6.5	6.5
11.66	9.7	9.7	3.2	16.1	3.2	6.5	6.5	9.7	9.7	6.5	6.5
11.38	9.7	9.7	3.2	16.1	3.2	6.5	6.5	9.7	9.7	6.5	6.5
11.10	9.7	9.7	3.2	16.1	3.2	6.5	6.5	9.7	9.7	6.5	6.5
10.89	9.7	9.7	3.2	16.1	3.2	6.5	6.5	9.7	9.7	6.5	6.5
10.75	9.7	9.7	3.2	16.1	3.2	6.5	6.5	9.7	9.7	6.5	6.5
10.54	6.5	9.7	3.2	16.1	3.2	6.5	6.5	6.5	9.7	6.5	6.5
10.26	6.5	9.7	3.2	16.1	3.2	6.5	6.5	6.5	9.7	6.5	6.5
9.98	12.9	16.1	12.9	19.4	6.5	9.7	9.7	12.9	16.1	12.9	9.7
9.70	9.7	9.7	9.7	16.1	3.2	12.9	6.5	9.7	9.7	9.7	9.7
9.42	16.1	19.4	9.7	22.6	9.7	16.1	12.9	9.7	9.7	9.7	6.5
9.14	16.1	16.1	6.5	22.6	9.7	16.1	12.9	9.7	6.5	9.7	3.2
8.86	12.9	16.1	6.5	22.6	9.7	16.1	9.7	6.5	6.5	9.7	3.2
8.58	12.9	12.9	3.2	19.4	9.7	16.1	9.7	6.5	6.5	9.7	3.2
8.30	12.9	12.9	3.2	19.4	9.7	16.1	9.7	6.5	6.5	6.5	3.2
8.02	9.7	12.9	3.2	19.4	6.5	16.1	9.7	6.5	6.5	6.5	3.2
7.74	12.9	12.9	3.2	19.4	6.5	16.1	9.7	6.5	6.5	6.5	3.2
7.46	12.9	12.9	3.2	19.4	6.5	16.1	9.7	6.5	6.5	6.5	3.2
7.25	12.9	12.9	0.0	19.4	6.5	16.1	9.7	6.5	6.5	6.5	3.2
7.11	12.9	12.9	3.2	19.4	6.5	16.1	9.7	6.5	6.5	6.5	3.2
6.90	12.9	12.9	3.2	19.4	6.5	12.9	9.7	6.5	6.5	6.5	3.2
6.62	9.7	12.9	3.2	19.4	6.5	12.9	9.7	6.5	6.5	6.5	3.2
6.34	9.7	9.7	3.2	19.4	6.5	9.7	9.7	6.5	6.5	3.2	3.2
6.13	9.7	9.7	3.2	19.4	6.5	9.7	9.7	6.5	6.5	3.2	3.2
5.99	9.7	9.7	0.0	19.4	6.5	9.7	9.7	6.5	6.5	3.2	3.2
5.81	9.7	9.7	3.2	16.1	6.5	9.7	6.5	6.5	6.5	6.5	3.2
5.67	9.7	12.9	0.0	19.4	6.5	9.7	9.7	6.5	6.5	3.2	3.2
5.57	9.7	9.7	0.0	16.1	6.5	9.7	6.5	6.5	6.5	3.2	3.2
5.43	9.7	12.9	3.2	19.4	6.5	9.7	9.7	6.5	6.5	6.5	6.5
5.34	9.7	12.9	3.2	19.4	6.5	9.7	9.7	6.5	6.5	6.5	6.5
5.20	9.7	12.9	3.2	19.4	6.5	9.7	9.7	6.5	6.5	6.5	6.5
5.01	9.7	12.9	3.2	19.4	6.5	9.7	9.7	9.7	9.7	6.5	6.5
4.87	12.9	12.9	3.2	19.4	6.5	9.7	9.7	9.7	9.7	6.5	6.5
4.66	12.9	12.9	3.2	19.4	6.5	9.7	9.7	9.7	9.7	6.5	6.5
4.38	12.9	12.9	3.2	19.4	9.7	9.7	9.7	9.7	9.7	6.5	6.5
4.17	12.9	12.9	3.2	19.4	9.7	9.7	9.7	9.7	9.7	6.5	6.5
4.03	12.9	12.9	3.2	19.4	9.7	9.7	9.7	9.7	9.7	6.5	6.5
3.82	12.9	12.9	6.5	19.4	9.7	12.9	9.7	9.7	9.7	9.7	6.5

